

Systems
&
Solutions

Engineered
vibration testing
solutions for
improved
product quality.

Team Corporation
11591 Watertank Road
Burlington, WA 98233
Tel: (360) 757-8601
Fax: (360) 757-4401
sales@teamcorporation.com
www.teamcorporation.com

Team Corporation UK Ltd
11 Old Ladies Court
High Street
Battle
East Sussex
TN33 0AH
United Kingdom
Tel: +44 (0) 1424 777004
Fax: +44 (0) 1424 777005
sales@teamcorporation.co.uk
service@teamcorporation.co.uk
www.teamcorporation.co.uk

Hydraulic Power Supplies

Team Corporation manufactures a variety of Hydraulic Power Supplies for use in vibration test systems and other high-precision servo systems.

The selection of the HPS is based largely on the selection of the servovalve. The HPS and servovalve are selected to provide the desired velocity.

In addition, *Team* HPS's are remotely controlled and monitored using the *Team* 1510 Hydraulic Pump Controller.



Features:

- Built-in heat exchangers with water saving valves
- High and low flow modes for safe start-up
- Filtration to keep the oil in the ISO 15/13/10 condition required for servosystems
- Health monitoring sensors including oil temperature and level, pressure and filter condition.

Applications:

- Hydraulic power supplies for vibration test systems and other precision servo systems.

Sample Specifications

HPS Model	Flow	Horsepower	Cooling Water	Length x Width x Height
HPS-25	7 gpm	15 hp	4 gpm @ 80°F	48 x 36 x 60 in.
HPS-65	15 gpm	40 hp	8 gpm @ 80°F	72 x 36 x 60 in.
HPS-110	30 gpm	60 hp	16 gpm @ 80°F	72 x 36 x 60 in.
HPS-190	50 gpm	100 hp	Call Team	84 x 42 x 60 in.
HPS-265	70 gpm	125 hp	38 gpm @ 80°F	110 x 72 x 80 in.
HPS-380	100 gpm	200 hp	55 gpm @ 80°F	110 x 72 x 80 in.
HPS-460	120 gpm	240 hp	Call Team	110 x 72 x 80 in.
HPS-535	140 gpm	280 hp	Call Team	110 x 72 x 80 in.
HPS-650	170 gpm	340 hp	Call Team	110 x 72 x 80 in.
HPS-800	210 gpm	420 hp	Call Team	110 x 72 x 80 in.

Example of a typical Team HPS (HPS-3-380)

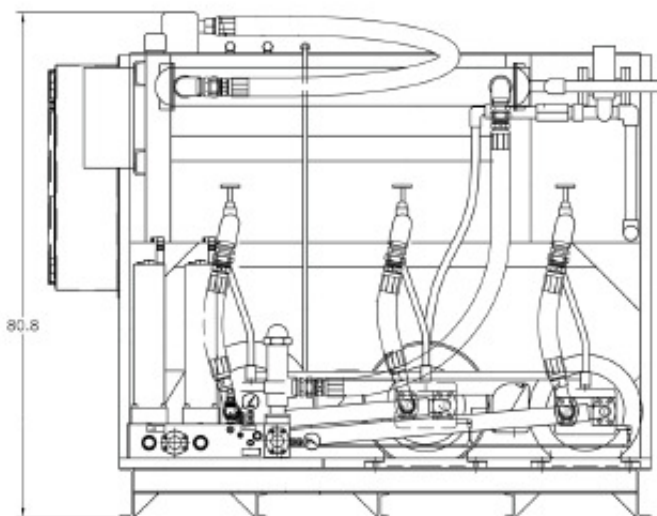

Elevation View

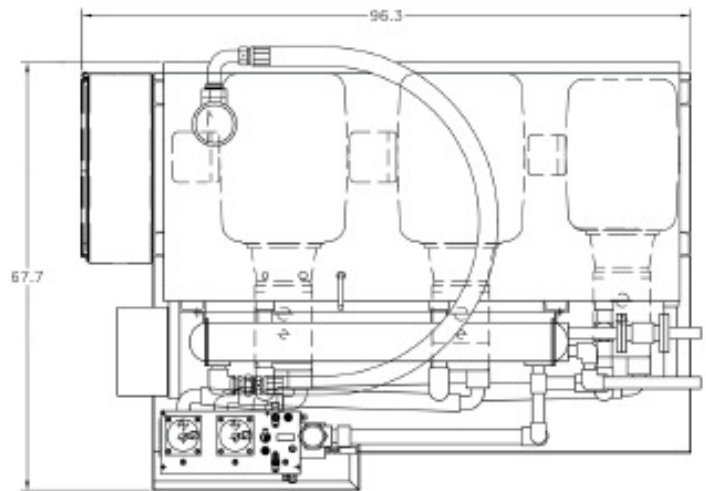

Plan View