

## PIPING

Catalogue No. 8801, Section 3



BÜCHI – THE WAY TO GET RESULTS!



 **büchiglasuster**  
switzerland Pilot Plant and Reactor Systems

## Table of contents

### Page

3.2	Tube «büchiflex»
3.4	Tube adapter
3.6	Reducer
3.8	Elbow «büchiflex»
3.9	90° reducing elbow «büchiflex»
3.10	87° reducing elbow «büchiflex»
3.11	Tee «büchiflex»
3.12	Reducing tee «büchiflex»
3.13	87° Tee «büchiflex»
3.14	87° Reducing tee «büchiflex»
3.15	Y-piece «büchiflex»
3.16	Cross «büchiflex»
3.17	U-bend «büchiflex»
3.18	U-bend with bottom outlet «büchiflex»
3.19	Plug
3.20	Dip pipe DN 15-100
3.21	87° Dip pipe DN 15-100
3.22	Dip pipe, angled
3.23	Gas inlet tube
3.24	Sprinkler head horizontal
3.25	Dropping glass
3.26	Flexible tube connection «büchiflex»
3.27	Plane joint tube «PS»
3.28	Plug «KF»
3.29	Tube «KF»
3.30	Elbow «KF»
3.31	Tee «KF»
3.32	Reducing tee «KF»

#### Note:

All basic data and information relating to borosilicate glass 3.3 apparatus and piping construction are contained in section 2 of catalogue No. 8801.

There you will find detailed information concerning:

- Properties of Borosilicate glass 3.3
- Permissible operating conditions
- Modular system «büchiglas»
- Design and construction
- Installation and start-up
- Safety regulations

Please state the complete order number when ordering to avoid unnecessary queries and delivery delays!

«büchiflex» and «chemReactor» are trademarks of Büchi AG, Uster.

## Rohr «büchiflex» DN 15-150

### Tube «büchiflex»

### Conduite «büchiflex»

DN	L [mm]	Bestell-Nr. Art. No./no de cde
15	75	10.00015.0075
15	100	10.00015.0100
15	125	10.00015.0125
15	150	10.00015.0150
15	175	10.00015.0175
15	200	10.00015.0200
15	250	10.00015.0250
15	300	10.00015.0300
15	400	10.00015.0400
15	500	10.00015.0500
15	750	10.00015.0750
15	1000	10.00015.1000
15	1500	10.00015.1500
15	2000	10.00015.2000

Sonderlängen  
Non-standard lengths  
Longueurs spéciales  
L = min. 50 mm, max. 3000 mm

DN	L [mm]	Bestell-Nr. Art. No./no de cde
25	75	10.00025.0075
25	100	10.00025.0100
25	125	10.00025.0125
25	150	10.00025.0150
25	175	10.00025.0175
25	200	10.00025.0200
25	250	10.00025.0250
25	300	10.00025.0300
25	400	10.00025.0400
25	500	10.00025.0500
25	750	10.00025.0750
25	1000	10.00025.1000
25	1500	10.00025.1500
25	2000	10.00025.2000
25	3000	10.00025.3000

Sonderlängen  
Non-standard lengths  
Longueurs spéciales  
L = min. 60 mm, max. 3000 mm

DN	L [mm]	Bestell-Nr. Art. No./no de cde
40	100	10.00040.0100
40	125	10.00040.0125
40	150	10.00040.0150
40	175	10.00040.0175
40	200	10.00040.0200
40	250	10.00040.0250
40	300	10.00040.0300
40	400	10.00040.0400
40	500	10.00040.0500
40	750	10.00040.0750
40	1000	10.00040.1000
40	1500	10.00040.1500
40	2000	10.00040.2000
40	3000	10.00040.3000

Sonderlängen  
Non-standard lengths  
Longueurs spéciales  
L = min. 70 mm, max. 3000 mm

DN	L [mm]	Bestell-Nr. Art. No./no de cde
150	150	10.00150.0150
150	175	10.00150.0175
150	200	10.00150.0200
150	300	10.00150.0300
150	400	10.00150.0400
150	500	10.00150.0500
150	750	10.00150.0750
150	1000	10.00150.1000
150	1500	10.00150.1500
150	2000	10.00150.2000
150	3000	10.00150.3000

Sonderlängen  
Non-standard lengths  
Longueurs spéciales  
L = min. 150 mm, max. 3000 mm

### Deutsch

#### Bestellung von Sonderlängen

Bei der Planung und Realisierung von Rohrleitungen ist grundsätzlich der Einsatz von Normlängen anzustreben. Zudem sind Normlängen in der Regel ab Lager lieferbar. In gewissen Fällen sind jedoch Sonderlängen nach Ausmass unumgänglich. Innerhalb der aufgeführten minimalen und maximalen Herstellungslängen können Sonderlängen wie folgt bestellt werden:

#### Bestellung von Glasbauteilen mit «büchiglas»-Beschichtung

Alle in dieser Druckschrift aufgeführten Glasbauteile können mit der «büchiglas»-Beschichtung geliefert werden. Mit Ausnahme der Gruppennummer (die ersten zwei Ziffern der Nummerngruppe), welche von 10. ... auf 11. ... geändert wird, bleibt die jeweilige Bestell-Nummer unverändert.

### English

#### Ordering non-standard lengths

Low-cost standard lengths should be used as a matter of principle when piping systems are designed and implemented. Standard lengths are usually available ex stock. However, non-standard lengths are sometimes unavoidable. Such lengths can be ordered within the specified minimum and maximum values as follows:

#### Ordering glass components with «büchiglas» coating

All the glass components in this publication can be supplied with «büchiglas» coating. With the exception of the group number (the first two figures of the number group) which is changed from 10. ... to 11. ..., the respective order number remains unchanged.

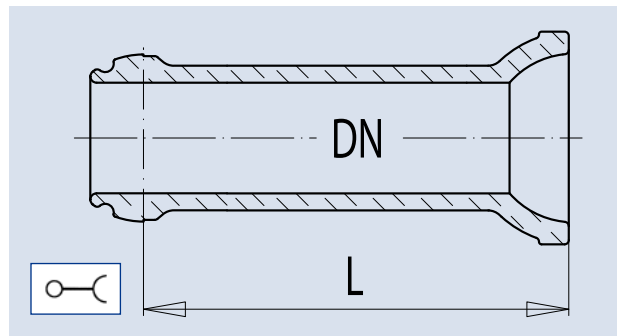

DN	L [mm]	Bestell-Nr. Art. No./no de cde
50	100	10.00050.0100
50	125	10.00050.0125
50	150	10.00050.0150
50	175	10.00050.0175
50	200	10.00050.0200
50	250	10.00050.0250
50	300	10.00050.0300
50	400	10.00050.0400
50	500	10.00050.0500
50	750	10.00050.0750
50	1000	10.00050.1000
50	1500	10.00050.1500
50	2000	10.00050.2000
50	3000	10.00050.3000

Sonderlängen  
Non-standard lengths  
Longueurs spéciales  
L = min. 80 mm, max. 3000 mm

DN	L [mm]	Bestell-Nr. Art. No./no de cde
70	100	10.00070.0100
70	125	10.00070.0125
70	150	10.00070.0150
70	175	10.00070.0175
70	200	10.00070.0200
70	300	10.00070.0300
70	400	10.00070.0400
70	500	10.00070.0500
70	750	10.00070.0750
70	1000	10.00070.1000
70	1500	10.00070.1500
70	2000	10.00070.2000
70	3000	10.00070.3000

Sonderlängen  
Non-standard lengths  
Longueurs spéciales  
L = min. 90 mm, max. 3000 mm

DN	L [mm]	Bestell-Nr. Art. No./no de cde
100	125	10.00100.0125
100	150	10.00100.0150
100	175	10.00100.0175
100	200	10.00100.0200
100	300	10.00100.0300
100	400	10.00100.0400
100	500	10.00100.0500
100	750	10.00100.0750
100	1000	10.00100.1000
100	1500	10.00100.1500
100	2000	10.00100.2000
100	3000	10.00100.3000

Sonderlängen  
Non-standard lengths  
Longueurs spéciales  
L = min. 110 mm, max. 3000 mm

## Français

### Commande de longueurs spéciales

Dans la planification et la réalisation des conduites, on doit fondamentalement rechercher à utiliser des longueurs normalisées avantageuses. D'autre part, les longueurs normalisées sont, en règle générale, disponibles du stock. Cependant, dans certains cas, des longueurs spéciales sur mesure sont incontournables. Des longueurs spéciales peuvent être commandées comme suit à l'intérieur des longueurs de commande minimales et maximales mentionnées:

### Commande de composants en verre revêtu

Le revêtement de tous les éléments en verre contenus dans cette brochure est possible. Le numéro de commande correspondant n'est pas modifié à l'exception du numéro de groupe (les deux premiers chiffres du numéro de groupe) qui est modifié de 10. ... à **11. ...**

### Bestellbeispiel:/Ordering example:/Exemple de commande:















10	00025	2550	<ul style="list-style-type: none"> <li>Sonderlänge L = 2550 mm</li> <li>Non-standard L = 2550 mm</li> <li>Longueur spécial L = 2550 mm</li> </ul>
			<ul style="list-style-type: none"> <li>Rohr «büchiflex», DN 25</li> <li>«büchiflex» tube, DN 25</li> <li>Conduite «büchiflex» DN 25</li> </ul>
			<ul style="list-style-type: none"> <li>10. ... = blank</li> <li>10. ... = plain</li> <li>10. ... = nu</li> </ul>

11	00070	1500	<ul style="list-style-type: none"> <li>L = 1500 mm</li> <li>L = 1500 mm</li> <li>L = 1500 mm</li> </ul>
			<ul style="list-style-type: none"> <li>Rohr «büchiflex», DN 70</li> <li>«büchiflex» tube, DN 70</li> <li>Conduite «büchiflex» DN 70</li> </ul>
			<ul style="list-style-type: none"> <li>11. ... = beschichtet</li> <li>11. ... = coated</li> <li>11. ... = revêtu</li> </ul>

# Übergangsstück DN 15-150

## Tube adapter

## Raccord

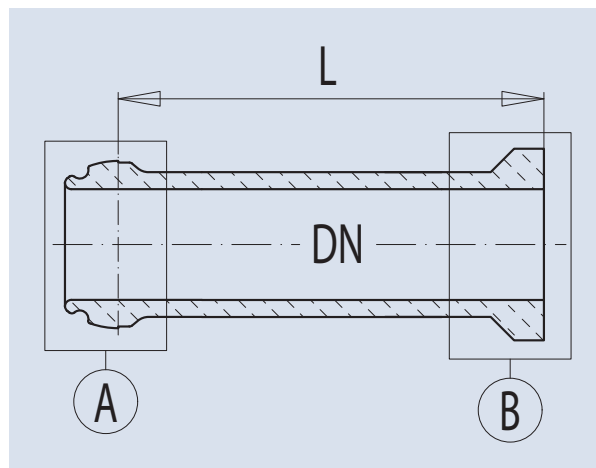

DN	L [mm]	Ⓐ / Ⓑ	Bestell-Nr. Art. No./no de cde
15	75		10.01015.0000
15	75		10.01016.0000
25	75		10.01025.0000
25	75		10.01026.0000
40	100		10.01040.0000
40	100		10.01041.0000
50	125		10.01050.0000
50	125		10.01051.0000
70	150		10.01070.0000
70	150		10.01071.0000
100	175		10.01100.0000
100	175		10.01101.0000
150	200		10.01150.0000
150	200		10.01151.0000



### Deutsch

Zum Anschluss von «büchiglas»-Bauteilen an andere Werkstoffe werden kurze Übergangstücke mit einseitigem «büchiglas»-Planschliff eingesetzt.



#### Schliffarten

- 1 =  «büchiflex»-Kugel
- 2 =  «büchiflex»-Pfanne
- 3 =  «büchiglas»-Planschliff

### English

Short adapter lengths with one end configured for a «büchiglas» plane joint are used to connect «büchiglas» components to components made of other materials.



#### Types of grinding

- 1 =  «büchiflex» ball
- 2 =  «büchiflex» socket
- 3 =  «büchiglas» plane joint

### Français

De courts raccords à rodage plan «büchiglas» sur un côté sont utilisés pour le raccordement des composants «büchiglas» à d'autres matières.

#### Genres de rodage

- 1 =  rodage mâle «büchiflex»
- 2 =  rodage femelle «büchiflex»
- 3 =  rodage plan «büchiglas»

## Deutsch

### Bestellung von Sonderlängen

Grundsätzlich ist der Einsatz von Normlängen anzustreben, welche ab Lager lieferbar sind.

Sonderlängen können innerhalb der auf den Seiten 3.2/3.3 aufgeführten minimalen und maximalen Herstellungslängen geliefert werden. Die Bestell-Nr. ist dabei mit der gewünschten Sonderlänge zu ergänzen.

### Wichtiger Hinweis

«büchiglas»-Normbauteile können mit entsprechenden Übergangsstücken an Rohrverbindungen anderer Glashersteller angeschlossen werden. Für die Herstellung eines Übergangsstückes auf andere Verbindungssysteme benötigen wir folgende Angaben:

- Hersteller
- DN und Schliffart des anzuschliessenden Glasbauteiles.

Zusätzliche Informationen über andere Verbindungssysteme/Schliffarten können im Kapitel 2 «Technische Informationen» gefunden werden.

## English

### Ordering of non-standard lengths

Standard lengths, which can be supplied ex stock should be used as a matter of principle wherever possible.

Non-standard lengths within the minimum and maximum lengths indicated on pages 3.2/3.3 can be supplied. Add the required non-standard length to the order number.

### Important note

«büchiglas» standard components can be connected to the tube connections of other manufacturers with suitable adapters. We require the following data to manufacture an adapter for non-Büchi connecting systems:

- Manufacturer
- DN and type of grinding of the glass component to be connected.

Additional information about different connections/types of grindings can be found in chapter 2 «Technical informations».

## Français

### Commande de longueurs spéciales

En principe, on doit chercher à utiliser des longueurs normalisées qui sont disponibles du stock.

Des longueurs spéciales peuvent être fournies à l'intérieur des longueurs de fabrication minimales et maximales mentionnées aux pages 3.2/3.3. Le numéro de commande doit alors être complété par la longueur spéciale souhaitée.

### Remarque importante

Les composants normalisés «büchiglas» peuvent être raccordés avec les raccords correspondant aux systèmes de conduites d'autre fabricants de verrerie. Nous avons besoin des indications suivantes pour fabriquer un raccord à un autre système de raccords:

- Fabricant
  - DN et genre de rodage du composant en verre à raccorder.
- Informations supplémentaires de différents connections/types de rodages vous trouvez en chapitre 2 «Informations techniques».

### Beispiel für Sonderlänge:

### Ordering example for non-standard length:

### Exemple de commande de longueurs spéciales:

10 01040 0150

Sonderlänge L = 150 mm

• Non-standard L = 150 mm

Longueur spéciale L = 150 mm

Übergangsstück DN 40, Schliffkombination 1/3

• Tube adapter DN 40, grinding combination 1/3

Raccord DN 40, combinaison de rodages 1/3

• 10. ... = blank/plain/nu

(11. ... = beschichtet/coated/revêtu)

# Reduktion DN 15-200

## Reducer

## Réduction

DN1	DN2	L [mm]	Art.-Nr. Art. No./no d'art.
25	15	100	10.01300. ...
*32	15	100	10.01310. ...
*32	25	100	10.01320. ...
40	15	100	10.01330. ...
40	25	100	10.01340. ...
40	*32	100	10.01350. ...
50	15	150	10.01360. ...
50	25	150	10.01370. ...
50	*32	150	10.01380. ...
50	40	150	10.01390. ...
*60	15	150	10.01400. ...
*60	25	150	10.01410. ...
*60	40	150	10.01420. ...
*60	50	150	10.01430. ...
70	15	150	10.01440. ...
70	25	150	10.01450. ...
70	*32	150	10.01460. ...
70	40	150	10.01470. ...
70	50	150	10.01480. ...
70	*60	150	10.01490. ...
*80	15	150	10.01500. ...
*80	25	150	10.01510. ...
*80	40	150	10.01520. ...
*80	50	150	10.01530. ...
*80	70	150	10.01540. ...
100	15	150	10.01550. ...
100	25	150	10.01560. ...
100	*32	150	10.01570. ...
100	40	150	10.01580. ...
100	50	150	10.01590. ...
100	*60	150	10.01600. ...
100	70	150	10.01610. ...
100	*80	150	10.01620. ...

DN1	DN2	L [mm]	Art.-Nr. Art. No./no d'art.
*115	15	150	10.01630. ...
*115	25	150	10.01640. ...
*115	40	150	10.01650. ...
*115	50	150	10.01660. ...
*115	70	150	10.01670. ...
*115	100	150	10.01680. ...
*125	15	150	10.01690. ...
*125	25	150	10.01700. ...
*125	40	150	10.01710. ...
*125	50	150	10.01720. ...
*125	70	150	10.01730. ...
*125	100	150	10.01740. ...
150	15	200	10.01750. ...
150	25	200	10.01760. ...
150	*32	200	10.01770. ....
150	40	200	10.01780. ...
150	50	200	10.01790. ...
150	*60	200	10.01800. ...
150	70	200	10.01810. ...
150	*80	200	10.01820. ....
150	100	200	10.01830. ...
150	*115	200	10.01840. ...
150	*125	200	10.01850. ...
*200	15	200	10.01860. ...
*200	25	200	10.01870. ...
*200	40	200	10.01880. ...
*200	50	200	10.01890. ...
*200	70	200	10.01900. ...
*200	100	225	10.01910. ...
*200	150	225	10.01920. ...

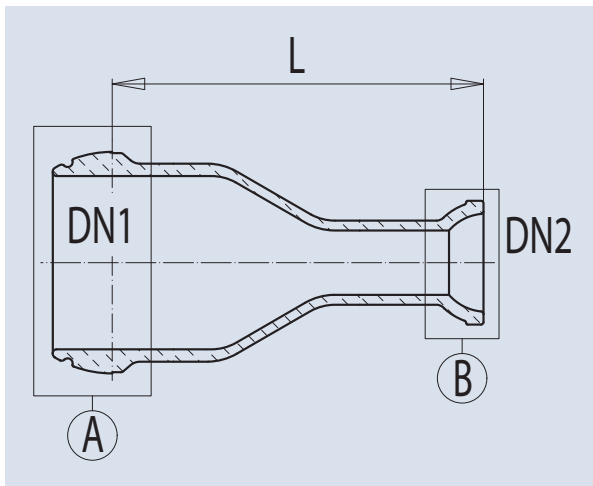

\* DN1 und DN2 mit \* bezeichnet sind nur mit «büchiglas»-Planschiff lieferbar! (Kennziffer 3)  
 \* DN1 and DN2 marked with \* are available with the «büchiglas» plane joint only! (code number 3)  
 \* Si DN1 et DN2 sont repérés par une \*, ils ne sont livrables qu'avec un rodage plan «büchiglas»! (Indice 3)



## Deutsch

«büchiglasuster» bietet ein breit ausgelegtes Programm von Reduktionen an. Bei sinnvoller Wahl von Schliffart und Schliffkombination lassen sich Rohrverbindungen in sehr grosser Zahl einsparen. Die Bestell-Nr. wird aus Art.-Nr. und Kenn-Nr. der gewünschten Schliffkombination gemäss Bestellbeispiel gebildet.



### Schliffarten

- 1 =  «büchiflex»-Kugel
- 2 =  «büchiflex»-Pfanne
- 3 =  «büchiglas»-Planschliff

## English

«büchiglasuster» offers a wide range of reducers. A very large number of tubing connectors can be saved if the correct type of grinding and grinding combination is chosen. The order number is formed from the article number and the code number of the desired grinding combination in accordance with the ordering example.



### Types of grinding

- 1 =  «büchiflex» ball
- 2 =  «büchiflex» socket
- 3 =  «büchiglas» plane joint

## Français









«büchiglasuster» offre un vaste programme de réductions. Un très grand nombre de raccords peut être économisé en choisissant judicieusement le genre et la combinaison de rodages. Le numéro de commande est constitué du numéro d'article et de l'indice de la combinaison de rodages souhaitée conformément à l'exemple de commande.

### Genres de rodage

- 1 =  rodage mâle «büchiflex»
- 2 =  rodage femelle «büchiflex»
- 3 =  rodage plan «büchiglas»

## Kenn-Nr. für Schliffkombinationen Code number for grinding combinations Indice pour les combinaisons de rodages

10 01470 0010

(A) / (B)		(A) / (B)
	0010	(1/2)
	0020	(2/1)
	0030	(1/1)
	0040	(2/2)
	0050	(3/1)
	0060	(3/2)
	0070	(1/3)
	0080	(2/3)

Reduktion DN 70/40

• Reducer DN 70/40 (Beispiel)

Réduction DN 70/40

• 10. ... = blank/plain/nu

(11. ... = beschichtet/coated/revêtue)

Vorzugsreihe

Preferred series

Série préférentielle



# Bogen «büchiflex» DN 15-150

## Elbow «büchiflex»

## Coude «büchiflex»

DN	L [mm]	Art.-Nr. Art. No./no d'art.
15	75	10.02500. ...
25	75	10.02510. ...
40	100	10.02520. ...
50	150	10.02530. ...
70	150	10.02540. ...
100	225	10.02550. ...
150	300	10.02560. ...

### Bestellbeispiel: Kenn-Nr. für Schliffkombinationen und Winkelgrade

Ordering example: Code number for grinding combinations and for angles

Exemple de commande: Indice pour les combinaisons de rodages et des degrés angulaires

Winkel = 45°  
Angle = 45°  
Angle = 45°

Winkel	Code
15°	15
30°	30
45°	45
60°	60
75°	75
85°	85
87°	87
90°	90

  

A/B	Code	A/B
1/2	10	(1/2)
1/1	20	(1/1)
2/2	30	(2/2)
3/1	40	(3/1)
3/2	50	(3/2)

Bogen «büchiflex», DN 50  
Elbow «büchiflex», DN 50 (Beispiel)  
Coude «büchiflex», DN 50

• 10. ... = blank/plain/nu  
(11. ... = beschichtet/coated/revêtu)

Auf Wunsch sind «büchiflex»-Bogen auch mit anderen Winkelgraden lieferbar.  
Elbows «büchiflex» can be supplied with other angles on request.  
Sur demande, des coudes sont également disponibles dans d'autres angles.

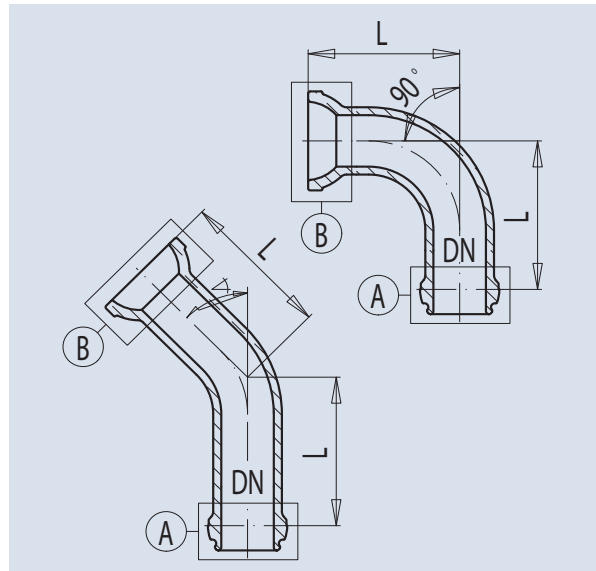

### Deutsch

Bogen-«büchiflex» sind standardmässig in 5 verschiedenen Schliffkombinationen und 8 verschiedenen Winkelgraden lieferbar. Die Bestell-Nr. wird aus Art.-Nr. und den Kenn-Nr. der gewünschten Schliffkombination und Winkelgrade gemäss Bestellbeispiel gebildet.

### Schliffarten

- 1 = «büchiflex»-Kugel
- 2 = «büchiflex»-Pflanne
- 3 = «büchiglas»-Planschliff

### English

Elbows «büchiflex» are available as standard in 5 different grinding combinations and 8 different angles. The order number is formed from the article number and the code number of the desired grinding combination and angle in accordance with the ordering example.

### Types of grinding

- 1 = «büchiflex» ball
- 2 = «büchiflex» socket
- 3 = «büchiglas» plane joint

### Français

Les coudes «büchiflex» sont disponibles en série dans 5 combinaisons de rodages et 8 degrés angulaires différents. Le numéro de commande est constitué à partir du numéro d'article et de l'indice de la combinaison de rodages et du degré angulaire souhaité conformément à l'exemple de commande.

### Genres de rodage

- 1 = rodage mâle «büchiflex»
- 2 = rodage femelle «büchiflex»
- 3 = rodage plan «büchiglas»

Vorzugsreihe  
Preferred series  
Série préférentielle

## Reduktionsbogen 90° DN 15-150

## 90° reducing elbow «büchiflex»

## Coude réducteur 90° «büchiflex»

DN <sub>1</sub>	DN <sub>2</sub>	L <sub>1</sub> [mm]	L <sub>2</sub> [mm]	Art.-Nr. Art. No./no d'art.
25	15	75	75	10.02700. ...
40	25	100	75	10.02710. ...
50	25	100	75	10.02725. ...
50	25	150	75	10.02720. ...
50	40	150	100	10.02730. ...
70	25	150	75	10.02740. ...
70	40	150	100	10.02750. ...
70	50	150	150	10.02760. ...
100	25	150	75	10.02770. ...
100	40	150	100	10.02780. ...
100	50	175	150	10.02790. ...
100	70	175	150	10.02800. ...
150	25	225	75	10.02810. ...
150	40	225	100	10.02820. ...
150	50	225	150	10.02830. ...
150	70	225	150	10.02840. ...
150	100	225	225	10.02850. ...

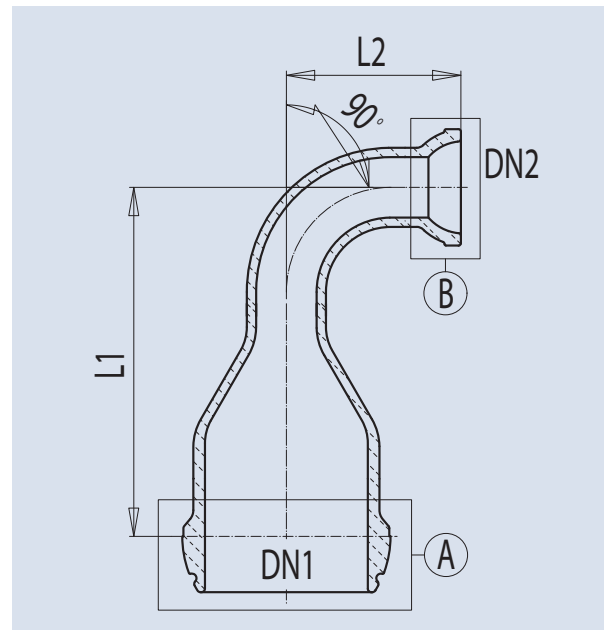



### Deutsch

Im Reduktionsbogen «büchiflex» sind Reduktion und 90°-Bogen in einem Bauteil vereinigt. Die Bestell-Nr. wird aus Art.-Nr. und Kenn-Nr. der gewünschten Schliffkombination gemäss Bestellbeispiel gebildet.

Auf Wunsch sind Reduktionsbogen «büchiflex» auch mit anderen Winkelgraden lieferbar.



### Schliffarten

- 1 =  «büchiflex»-Kugel
- 2 =  «büchiflex»-Pfanne
- 3 =  «büchiglas»-Planschliff

### English

The reducing elbows «büchiflex» consist of a combined reducer and 90° elbow. The order number is formed from the article number and the code number of the desired grinding combination and angle in accordance with the ordering example. Reducing elbows «büchiflex» can be supplied with other angles on request.

### Types of grinding



- 1 =  «büchiflex» ball
- 2 =  «büchiflex» socket
- 3 =  «büchiglas» plane joint

### Français

Dans le coude réducteur «büchiflex», le réducteur et le coude à 90° sont combinés en un composant. Le numéro de commande est constitué du numéro d'article et du numéro d'incide de la combinaison de rodages souhaitée conformément à l'exemple de commande.





Sur demande, les coudes réducteur «büchiflex» sont également disponibles dans d'autres angles.

### Genres de rodage

- 1 =  rodage mâle «büchiflex»
- 2 =  rodage femelle «büchiflex»
- 3 =  rodage plan «büchiglas»

### Kenn-Nr. für Schliffkombinationen Code number for grinding combinations Indice pour les combinaisons de rodages

10 02740 0020

(A) / (B)		(A) / (B)
	0010	(1/2)
	0020	(2/1)
	0030	(1/1)
	0040	(2/2)

Reduktionsbogen 90° «büchiflex»  
DN 70/25

- 90° reducing elbow «büchiflex» (Beispiel)  
DN 70/25
- Coude réducteur 90° «büchiflex»  
DN 70/25

- 10. ... = blank/plain/nu
- (11. ... = beschichtet/coated/revêtue)

Vorzugsreihe  
Preferred series  
Série préférentielle

## Reduktionsbogen 87° DN 15-150

## 87° reducing elbow «büchiflex»

## Coude réducteur 87° «büchiflex»

DN <sub>1</sub>	DN <sub>2</sub>	L <sub>1</sub> [mm]	L <sub>2</sub> [mm]	Art.-Nr. Art. No./no d'art.
25	15	75	75	10.02707....
40	25	100	75	10.02717....
50	25	100	75	10.02728....
50	25	150	75	10.02727....
50	40	150	100	10.02737....
70	25	150	75	10.02747....
70	40	150	100	10.02757....
70	50	150	150	10.02767....
100	25	150	75	10.02777....
100	40	150	100	10.02787....
100	50	175	150	10.02797....
100	70	175	150	10.02807....
150	25	225	75	10.02817....
150	40	225	100	10.02827....
150	50	225	150	10.02837....
150	70	225	150	10.02847....
150	100	225	225	10.02857....

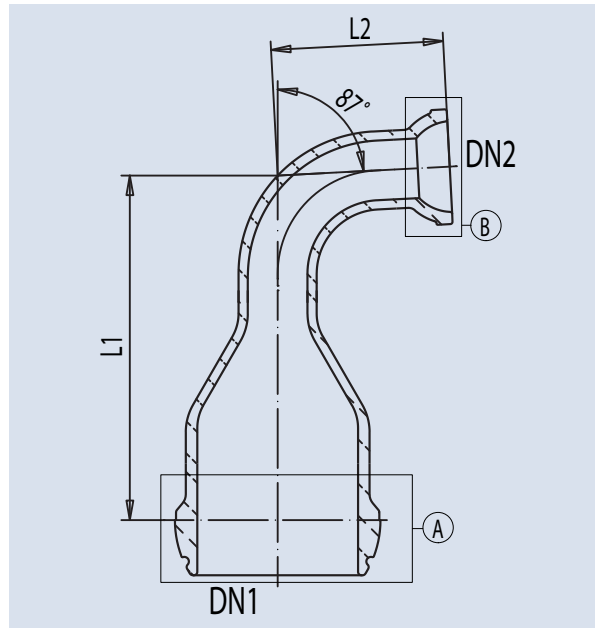



### Deutsch

Im Reduktionsbogen «büchiflex» sind Reduktion und 87°-Bogen in einem Bauteil vereinigt. Die Bestell-Nr. wird aus Art.-Nr. und Kenn-Nr. der gewünschten Schliffkombination gemäss Bestellbeispiel gebildet.

Auf Wunsch sind Reduktionsbogen «büchiflex» auch mit anderen Winkelgraden lieferbar.



### Schliffarten

- 1 =  «büchiflex»-Kugel
- 2 =  «büchiflex»-Pfanne
- 3 =  «büchiglas»-Planschliff

### English

The reducing elbows «büchiflex» consist of a combined reducer and 87° elbow. The order number is formed from the article number and the code number of the desired grinding combination and angle in accordance with the ordering example. Reducing elbows «büchiflex» can be supplied with other angles on request.

### Types of grinding



- 1 =  «büchiflex» ball
- 2 =  «büchiflex» socket
- 3 =  «büchiglas» plane joint

### Français

Dans le coude réducteur «büchiflex», le réducteur et le coude à 87° sont combinés en un composant. Le numéro de commande est constitué du numéro d'article et du numéro d'incide de la combinaison de rodages souhaitée conformément à l'exemple de commande.





Sur demande, les coudes réducteur «büchiflex» sont également disponibles dans d'autres angles.

### Genres de rodage

- 1 =  rodage mâle «büchiflex»
- 2 =  rodage femelle «büchiflex»
- 3 =  rodage plan «büchiglas»

### Kenn-Nr. für Schliffkombinationen Code number for grinding combinations Indice pour les combinaisons de rodages

10 02728 0010

(A) / (B)		(A) / (B)
	0010	(1/2)
	0020	(2/1)
	0030	(1/1)
	0040	(2/2)
	0050	(3/2)

Reduktionsbogen 87° «büchiflex»  
DN 50/25

• 87° reducing elbow «büchiflex» (Beispiel)  
DN 50/25

Coude réducteur 87° «büchiflex»  
DN 50/25

• 10. ... = blank/plain/nu  
(11. ... = beschichtet/coated/revêtue)

Vorzugsreihe  
Preferred series  
Série préférentielle



# T-Stück reduziert «büchiflex» DN 25-150

## Reducing tee «büchiflex»

### Élément en T réducteur «büchiflex»

DN <sub>1</sub>	DN <sub>2</sub>	L <sub>1</sub> [mm]	L <sub>2</sub> [mm]	Art.-Nr. Art. No./no d'art.
25	15	75	75	10.03200. ...
40	25	100	100	10.03210. ...
40	*32	100	100	10.03220. ...
50	25	150	100	10.03230. ...
50	*32	150	100	10.03240. ...
50	40	150	100	10.03250. ...
70	25	150	100	10.03260. ...
70	*32	150	100	10.03270. ...
70	40	150	125	10.03280. ...
70	50	150	125	10.03290. ...
70	*60	150	125	10.03300. ...
100	25	150	125	10.03310. ...
100	*32	150	125	10.03320. ...
100	40	150	125	10.03330. ...
100	50	150	125	10.03340. ...
100	*60	150	125	10.03350. ...
100	70	150	150	10.03360. ...
100	*80	150	150	10.03370. ...
150	25	225	150	10.03380. ...
150	*32	225	150	10.03390. ...
150	40	225	150	10.03400. ...
150	50	225	175	10.03410. ...
150	*60	225	175	10.03420. ...
150	70	225	175	10.03430. ...
150	*80	225	175	10.03440. ...
150	100	225	175	10.03450. ...

\* DN<sub>2</sub> mit \* bezeichnet, ist nur mit «büchiglas»-Planschliff lieferbar!  
 \* DN<sub>2</sub> marked with \* is available with the «büchiglas» plane joint only!  
 \* DN<sub>2</sub> repéré par une \* n'est disponible qu'avec le rodage plan «büchiglas»!

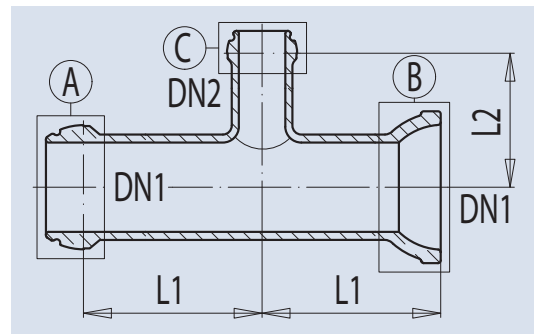

### Deutsch

Reduzierte T-Stücke erlauben platzsparende und wirtschaftliche Konstruktionen im Rohrleitungs- und Apparatebau. Die Bestell-Nr. wird aus Art.-Nr. und Kenn-Nr. der gewünschten Schliffkombinationen gebildet.

#### Schliffarten

- 1 = «büchiflex»-Kugel
- 2 = «büchiflex»-Pfanne
- 3 = «büchiglas»-Planschliff

### English

Reducing tees permit the space-saving and costeffective design of piping systems and apparatus. The order number is formed from the article number and the code number of the article number and the code number of the desired grinding combinations.

#### Types of grinding

- 1 = «büchiflex» ball
- 2 = «büchiflex» socket
- 3 = «büchiglas» plane joint

### Français

Les éléments en T réducteur permettent une construction de conduites et d'appareils économique et de faible encombrement. Le numéro de commande est constitué du numéro d'article et de l'indice des combinaisons de rodages souhaitées.

#### Genres de rodage

- 1 = rodage mâle «büchiflex»
- 2 = rodage femelle «büchiflex»
- 3 = rodage plan «büchiglas»

### Kenn-Nr. für Schliffkombinationen Code number for grinding combinations Indice pour les combinaisons de rodages

10	03280	0020	
T-Stück «büchiflex» reduziert, DN 70/40 • Reducing tee «büchiflex», DN 70/40 Élément en T «büchiflex» réducteur, DN 70/40			
• 10. ... = blank/plain/nu (11. ... = beschichtet/coated/revêtu)			

A/C/B		A/B/C
	0010	(1/2/1)
	0020	(1/2/2)
	0030	(1/2/3)

Vorzugsreihe  
Preferred series  
Série préférentielle

# T-Stück 87° «büchiflex» DN 15-150

## 87° Tee «büchiflex»

### Élément en T 87° «büchiflex»

DN	L [mm]	Art.-Nr. Art.No./no d'art.
15	75	10.03007. ....
25	75	10.03017. ....
40	100	10.03027. ....
50	150	10.03037. ....
70	150	10.03047. ....
100	150	10.03057. ....
150	225	10.03067. ....

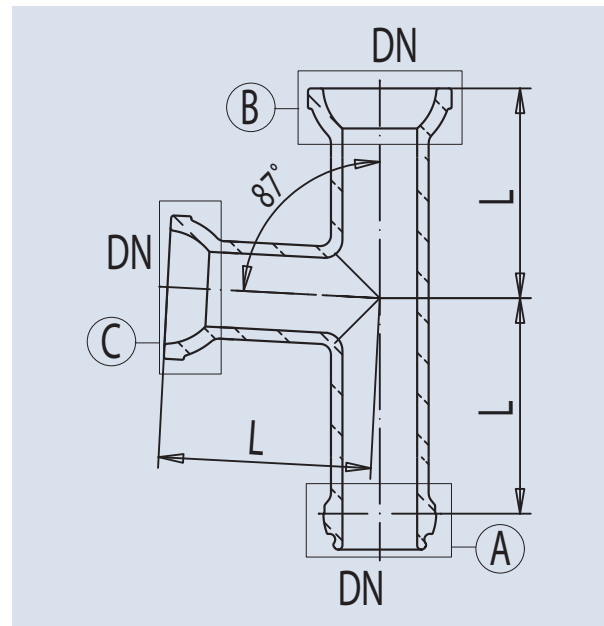



### Deutsch

Das grosse Sortiment an T-Stücken mit 87°-Abgang erlaubt bei sinnvoller Wahl der Schliffkombination, viele Rohrverbindungen einzusparen.

Die Bestell-Nr. wird aus Art.-Nr. und Kenn-Nr. der gewünschten Schliffkombination gemäss Bestellbeispiel gebildet.

### Schliffarten



- 1 =  «büchiflex»-Kugel
- 2 =  «büchiflex»-Pfanne
- 3 =  «büchiglas»-Planschliff

### English

The wide range of tees with a leg of 87° enables a large number of tube connections to be saved if the correct type of grinding and grinding combination are chosen.

The order number is formed from the article number and the code number of the desired grinding combination in accordance with the ordering example.

### Types of grinding



- 1 =  «büchiflex» ball
- 2 =  «büchiflex» socket
- 3 =  «büchiglas» plane joint

### Français

Le grand assortiment d'éléments en T à départ de 87° permet d'économiser de nombreux raccords dans le cas d'un choix judicieux de la combinaison de rodages.





















Le numéro de commande est constitué du numéro d'article et de l'indice de la combinaison de rodages souhaitée selon l'exemple de commande.

### Genres de rodage

- 1 =  rodage mâle «büchiflex»
- 2 =  rodage femelle «büchiflex»
- 3 =  rodage plan «büchiglas»

### Kenn-Nr. für Schliffkombinationen Code number for grinding combinations Indice pour les combinaisons de rodages

10 03017 0020

(A)/(C)/(B)		(A)/(C)/(B)
  	0010	(1/2/1)
  	0020	(1/2/2)
  	0030	(1/1/2)
  	0040	(2/2/1)
  	0050	(1/2/3)
  	0060	(1/3/2)
  	0070	(1/1/1)
  	0080	(2/2/2)

T-Stück «büchiflex» 87°, DN 25

• Tee «büchiflex» 87°, DN 25

Élément en T «büchiflex» 87°, DN 25

• 10. ... = blank/plain/nu

(11. ... = beschichtet/coated/revêtu)

Vorzugsreihe  
Preferred series  
Série préférentielle

# T-Stück reduziert 87° «büchiflex» DN 25-150

## 87° Reducing tee «büchiflex»

### Élément en T réducteur 87° «büchiflex»

DN <sub>1</sub>	DN <sub>2</sub>	L <sub>1</sub> [mm]	L <sub>2</sub> [mm]	Art.-Nr. Art. No./no d'art.
25	15	75	75	10.03207....
40	25	100	100	10.03217....
40	*32	100	100	10.03227....
50	25	150	100	10.03237....
50	*32	150	100	10.03247....
50	40	150	100	10.03257....
70	25	150	100	10.03267....
70	*32	150	100	10.03277....
70	40	150	125	10.03287....
70	50	150	125	10.03297....
70	*60	150	125	10.03307....
100	25	150	125	10.03317....
100	*32	150	125	10.03327....
100	40	150	125	10.03337....
100	50	150	125	10.03347....
100	*60	150	125	10.03357....
100	70	150	150	10.03367....
100	*80	150	150	10.03377....
150	25	225	150	10.03387....
150	*32	225	150	10.03397....
150	40	225	150	10.03407....
150	50	225	175	10.03417....
150	*60	225	175	10.03427....
150	70	225	175	10.03437....
150	*80	225	175	10.03447....
150	100	225	175	10.03457....

\* DN<sub>2</sub> mit \* bezeichnet ist nur mit «büchiglas»-Planschliff lieferbar!

\* DN<sub>2</sub> marked with \* is available with the «büchiglas» plane joint only!

\* DN<sub>2</sub> repéré par une \* n'est disponible qu'avec le rodage plan «büchiglas»!

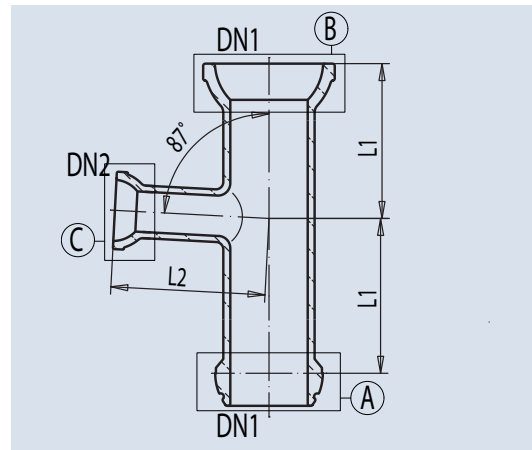

### Deutsch

Reduzierte T-Stücke mit 87°-Abgang erlauben platzsparende und wirtschaftliche Konstruktionen im Rohrleitungs- und Apparatebau. Die Bestell-Nr. wird aus Art.-Nr. und Kenn-Nr. der gewünschten Schliffkombinationen gebildet.

#### Schliffarten

- 1 = «büchiflex»-Kugel
- 2 = «büchiflex»-Pfanne
- 3 = «büchiglas»-Planschliff

### English

Reducing tees with a leg of 87° permit the space-saving and costeffective design of piping systems and apparatus.

The order number is formed from the article number and the code number of the article number and the code number of the desired grinding combinations.

#### Types of grinding

- 1 = «büchiflex» ball
- 2 = «büchiflex» socket
- 3 = «büchiglas» plane joint

### Français

Les éléments en T réducteur à départ de 87° permettent une construction de conduites et d'appareils économique et de faible encombrement. Le numéro de commande est constitué du numéro d'article et de l'indice des combinaisons de rodages souhaitées.

#### Genres de rodage

- 1 = rodage mâle «büchiflex»
- 2 = rodage femelle «büchiflex»
- 3 = rodage plan «büchiglas»

### Kenn-Nr. für Schliffkombinationen / Code number for grinding combinations / Indice pour les combinaisons de rodages

10	03287	0020	A/C/B		A/B/C
T-Stück reduziert 87° «büchiflex», DN 70/40 • 87° Reducing tee «büchiflex», DN 70/40 Élément en T réducteur 87° «büchiflex», DN 70/40  • 10. ... = blank/plain/nu (11. ... = beschichtet/coated/revêtu)				0010	(1/2/1)
				0020	(1/2/2)
				0030	(1/2/3)
				0040	(1/3/2)

Vorzugsreihe  
Preferred series  
Série préférentielle

## Y-Stück «büchiflex» DN 15-150

## Y-piece «büchiflex»

## Élément en Y «büchiflex»

DN	L [mm]	L <sub>1</sub> [mm]	L <sub>2</sub> [mm]	Bestell-Nr. Art. No./no de cde
15	150	50	100	10.03600.0000
25	150	50	100	10.03610.0000
40	200	75	125	10.03620.0000
50	300	100	200	10.03630.0000
70	300	100	200	10.03640.0000
100	300	100	200	10.03650.0000
150	450	150	300	10.03660.0000

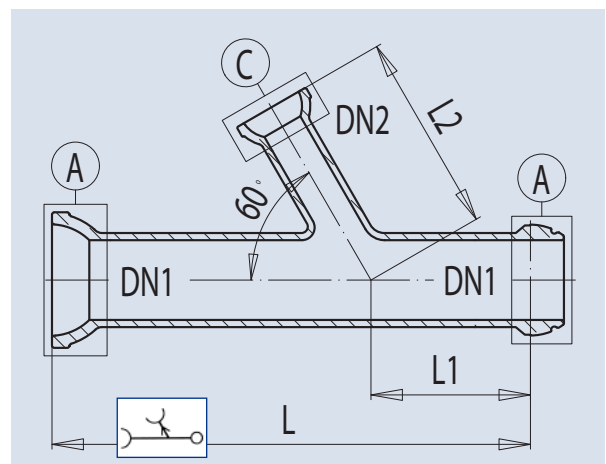
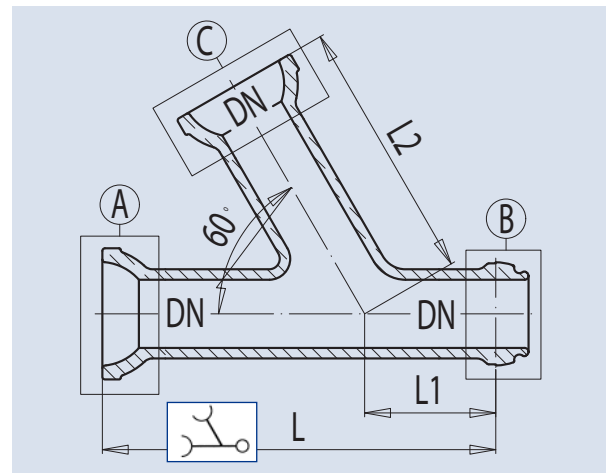

DN <sub>1</sub>	DN <sub>2</sub>	L [mm]	L <sub>1</sub> [mm]	L <sub>2</sub> [mm]	Bestell-Nr. Art. No./no de cde
25	15	150	50	75	10.03800.0000
40	25	200	75	100	10.03810.0000
50	25	300	100	125	10.03820.0000
50	40	300	100	150	10.03830.0000
70	25	300	100	125	10.03840.0000
70	40	300	100	150	10.03850.0000
70	50	300	100	150	10.03860.0000
100	25	300	100	150	10.03870.0000
100	40	300	100	150	10.03880.0000
100	50	300	100	175	10.03890.0000
100	70	300	100	200	10.03900.0000
150	25	300	50	175	10.03910.0000
150	40	300	50	200	10.03920.0000
150	50	300	50	200	10.03930.0000
150	70	300	75	225	10.03940.0000
150	100	300	75	225	10.03950.0000



### Deutsch

Auf Wunsch sind Y-Stücke «büchiflex» auch mit anderen Winkelgraden lieferbar. Bei Winkelöffnung über 75° richten sich alle Abmessungen nach den Normen für T-Stücke (Seite 3.10).



### Schliffarten

- 1 =  «büchiflex»-Kugel  
2 =  «büchiflex»-Pfanne

### English

Types of grinding: Y-pieces «büchiflex» can also be supplied with different angles on request. All dimensions are in accordance with the standards for tees for Y-angles greater than 75° (Page 3.10).



### Types of grinding

- 1 =  «büchiflex» ball  
2 =  «büchiflex» socket

### Français

Sur demande, les éléments en Y «büchiflex» sont également disponibles dans d'autres angles. Dans le cas d'une ouverture de l'angle supérieure à 75°, toutes les dimensions sont basées sur les normes des éléments en T (Page 3.10).

### Genres de rodage

- 1 =  rodage mâle «büchiflex»  
2 =  rodage femelle «büchiflex»



# Kreuzstück «büchiflex» DN 15-150

## Cross «büchiflex»

## Élément en croix «büchiflex»

DN	L [mm]	Art.-Nr. Art. No./no d'art.
15	75	10.04100. ...
25	75	10.04110. ...
40	100	10.04120. ...
50	150	10.04130. ...
70	150	10.04140. ...
100	150	10.04150. ...
150	225	10.04160. ...

### Kenn-Nr. für Schliffkombinationen Code number for grinding combinations Indice pour les combinaisons de rodages

10	04120	0020
----	-------	------

  

		Ⓐ / Ⓑ / Ⓒ / Ⓓ
	0010	(1/1/2/1)
	0020	(2/2/2/1)

Kreuzstück «büchiflex», DN 40  
 • Cross «büchiflex», DN 40  
 Élément en croix «büchiflex», DN 40

• 10. ... = blank/plain/nu  
 (11. ... = beschichtet/coated/revêtue)

Vorzugsreihe  
 Preferred series  
 Série préférentielle

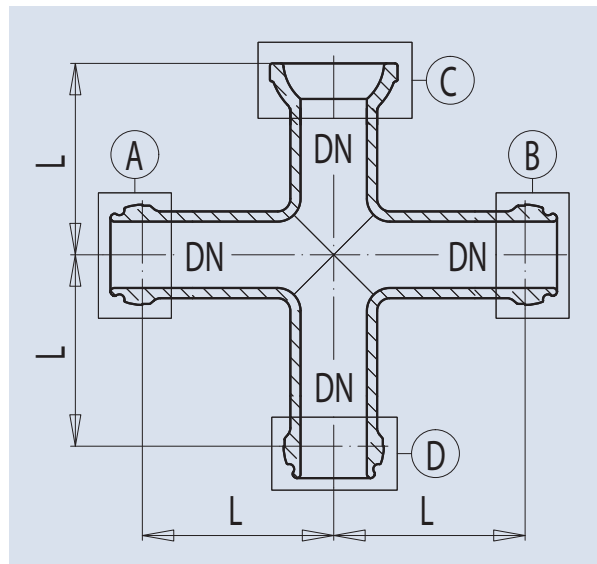

### Deutsch

Die Bestell-Nr. wird aus Art.-Nr. und Kenn-Nr. der gewünschten Schliffkombination gemäss Bestellbeispiel gebildet.

### Schliffarten

- 1 = «büchiflex»-Kugel
- 2 = «büchiflex»-Pfanne

### English

The order number is formed from the article number and the code number of the desired grinding combinations.

### Types of grinding

- 1 = «büchiflex» ball
- 2 = «büchiflex» socket

### Français

Le numéro de commande est constitué du numéro d'article et de l'indice de la combinaison de rodages souhaitée selon l'exemple de commande.

### Genres de rodage

- 1 = rodage mâle «büchiflex»
- 2 = rodage femelle «büchiflex»

## U-Bogen «büchiflex» DN 15-150

### U-bend «büchiflex»

### Coude en U «büchiflex»

DN	L [mm]	H <sub>1</sub> [mm]	Art.-Nr. Art. No./no d'art.
15	150	75	10.04300. ...
25	150	75	10.04310. ...
40	200	100	10.04320. ...
50	300	150	10.04330. ...
70	300	150	10.04340. ...
100	300	225	10.04350. ...
150	450	300	10.04360. ...

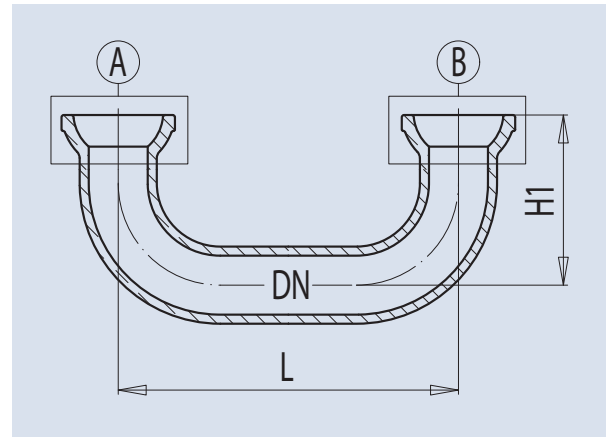

### Deutsch

Die Bestell-Nr. wird aus Art.-Nr. und Kenn-Nr. der gewünschten Schliffkombination gemäss Bestellbeispiel gebildet.

### Schliffarten

- 1 = «büchiflex»-Kugel  
 2 = «büchiflex»-Pfanne

### English

The order number is formed from the article number and the code number of the desired grinding combinations.

### Types of grinding

- 1 = «büchiflex» ball  
 2 = «büchiflex» socket

### Français

Le numéro de commande est constitué du numéro d'article et de l'indice de la combinaison de rodages souhaitée selon l'exemple de commande.

### Genres de rodage

- 1 = rodage mâle «büchiflex»  
 2 = rodage femelle «büchiflex»

### Kenn-Nr. für Schliffkombinationen Code number for grinding combinations Indice pour les combinaisons de rodages

10	04320	0010												
		<table border="1"> <thead> <tr> <th>A/B</th> <th></th> <th>A/B</th> </tr> </thead> <tbody> <tr> <td></td> <td>0010</td> <td>(1/1)</td> </tr> <tr> <td></td> <td>0020</td> <td>(2/2)</td> </tr> <tr> <td></td> <td>0030</td> <td>(2/1)</td> </tr> </tbody> </table>	A/B		A/B		0010	(1/1)		0020	(2/2)		0030	(2/1)
A/B		A/B												
	0010	(1/1)												
	0020	(2/2)												
	0030	(2/1)												
		U-Bogen «büchiflex», DN 40 • U-bend «büchiflex», DN 40 (Beispiel) Coude en U «büchiflex», DN 40												
		• 10. ... = blank/plain/nu (11. ... = beschichtet/coated/revêtue)												

Vorzugsreihe  
Preferred series  
Série préférentielle

# Hosenstück «büchiflex» DN 15-150

## U-bend with bottom outlet «büchiflex»

## Coude en U avec vidange «büchiflex»

DN	L [mm]	H <sub>1</sub> [mm]	H <sub>2</sub> [mm]	Art.-Nr. Art. No./no d'art.
15	150	75	75	10.04500. ...
25	150	75	75	10.04510. ...
40	200	100	100	10.04520. ...
50	300	150	150	10.04530. ...
70	300	150	150	10.04540. ...
100	300	225	150	10.04550. ...
150	450	300	225	10.04560. ...

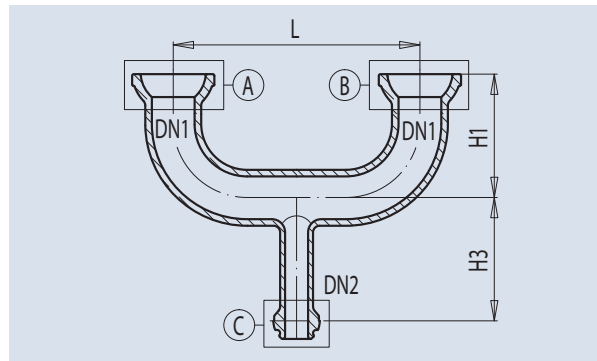
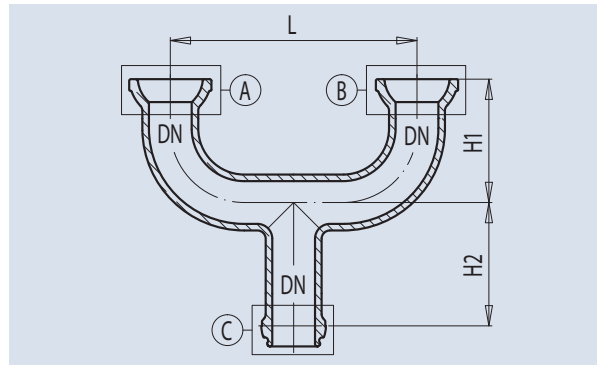

DN <sub>1</sub>	DN <sub>2</sub>	L [mm]	H <sub>1</sub> [mm]	H <sub>3</sub> [mm]	Art.-Nr. Art. No./no d'art.
25	15	150	75	75	10.04700. ...
40	25	200	100	100	10.04710. ...
50	25	300	150	100	10.04720. ...
50	40	300	150	100	10.04730. ...
70	25	300	150	100	10.04740. ...
70	40	300	150	125	10.04750. ...
70	50	300	150	125	10.04760. ...
100	25	300	225	125	10.04770. ...
100	40	300	225	125	10.04780. ...
100	50	300	225	125	10.04790. ...
100	70	300	225	150	10.04800. ...
150	25	450	300	150	10.04810. ...
150	40	450	300	150	10.04820. ...
150	50	450	300	150	10.04830. ...
150	70	450	300	175	10.04840. ...
150	100	450	300	175	10.04850. ...



### Deutsch

Die Bestell-Nr. wird aus Art.-Nr. und Kenn-Nr. der gewünschten Schliffkombination gemäss Bestellbeispiel gebildet.



### Schliffarten

- 1 =  «büchiflex»-Kugel
- 2 =  «büchiflex»-Pfanne

### English

The order number is formed from the article number and the code number of the desired grinding combinations.



### Types of grinding

- 1 =  «büchiflex» ball
- 2 =  «büchiflex» socket

### Français





Le numéro de commande est constitué du numéro d'article et de l'indice de la combinaison de rodages souhaitée selon l'exemple de commande.

### Genres de rodage

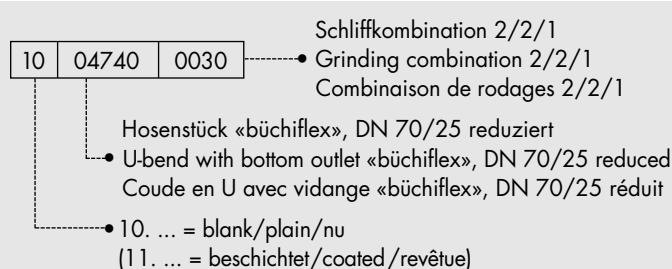
- 1 =  rodage mâle «büchiflex»
- 2 =  rodage femelle «büchiflex»

**Kenn-Nr. für Schliffkombinationen**  
**Code number for grinding combinations**  
**Indice pour les combinaisons de rodages**



(A)/(C)/(B)		(A)/(C)/(B)
	0010	(2/2/1)
	0020	(1/1/2)
	0030	(2/2/1)
	0040	(1/1/2)

**Vorzugsreihe**  
**Preferred series**  
**Série**  
**préférentielle**

# Blindverschluss DN 15-200

## Plug

## Fermeture dissimulée



DN	L [mm]	Art.-Nr. Art.No./no d'art.
15	45	10.05000. ...
25	50	10.05010. ...
*32	55	10.05020. ...
40	65	10.05030. ...
50	75	10.05040. ...
*60	80	10.05050. ...
70	90	10.05060. ...
*80	100	10.05070. ...
100	120	10.05080. ...
*115	130	10.05090. ...
*125	140	10.05100. ...
150	160	10.05110. ...
*200	180	10.05120. ...

\* DN mit \* bezeichnet ist nur mit «büchiglas»-Planschliff lieferbar!  
 \* DN marked with \* is available with the «büchiglas» plane joint only!  
 \* DN repéré par une \* n'est disponible qu'avec un rodage plan «büchiglas»!

### Kenn-Nr. für Schliiffart Code number for type of grinding Indice du genre de rodages

10	05010	0010
----	-------	------

  

Ⓐ		
	0010	(1)
	0020	(2)
	0030	(3)

Blindverschluss DN 25  
 • Plug DN 25  
 Fermeture dissimulée DN 25

• 10. ... = blank/plain/nu  
 (11. ... = beschichtet/coated/revêtue)

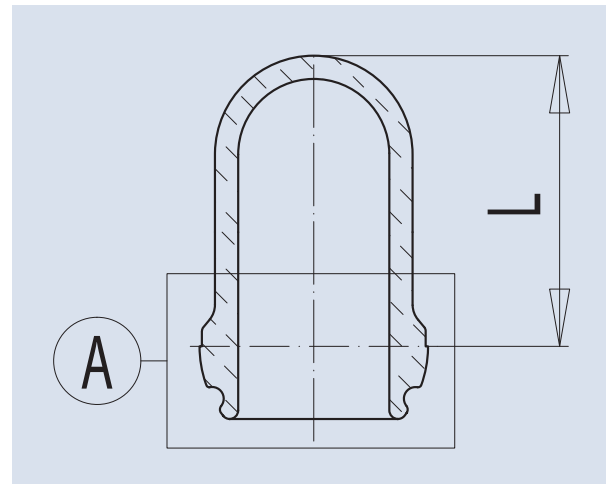

Vorzugsreihe  
 Preferred series  
 Série préférentielle



### Deutsch

Die Bestell-Nr. wird aus Art.-Nr. und Kenn-Nr. der gewünschten Schliiffkombination gemäss Bestellbeispiel gebildet.



#### Schliiffarten

- 1 =  «büchiflex»-Kugel
- 2 =  «büchiflex»-Pfanne
- 3 =  «büchiglas»-Planschliff

### English

The order number is formed from the article number and the code number of the desired grinding combinations.



#### Types of grinding

- 1 =  «büchiflex» ball
- 2 =  «büchiflex» socket
- 3 =  «büchiglas» plane joint

### Français

Le numéro de commande est constitué du numéro d'article et de l'indice de la combinaison de rodages souhaitée selon l'exemple de commande.

#### Genres de rodage

- 1 =  rodage mâle «büchiflex»
- 2 =  rodage femelle «büchiflex»
- 3 =  rodage plan «büchiglas»

## Einleitrohr DN 15-100

## Dip pipe DN 15-100

## Tube d'introduction DN 15-100

DN	DN <sub>1</sub>	L <sub>1</sub> [mm]	x	Art.-Nr. Art.No./no d'art.	Art.-Nr. Art.No./no d'art.
25	15	100	100	15.2000.0100	15.20200.0100
40	25	100	100	15.20010.0100	15.20210.0100
50	25	100	100	15.20060.0100	15.20330.0100
50	25	150	100	15.20020.0100	15.20220.0100
70	25	150	100	15.20030.0100	15.20230.0100
70	40	150	100	15.20040.0100	15.20240.0100
70	50	150	100	15.20050.0100	15.20250.0100
*80	25	150	100	-	15.20260.0100
*80	40	150	100	-	15.20270.0100
*80	50	150	100	-	15.20280.0100
100	25	150	100	15.20090.0100	15.20290.0100
100	40	150	100	15.20100.0100	15.20300.0100
100	50	150	100	15.20110.0100	15.20310.0100
100	70	150	100	15.20120.0100	15.20320.0100

DN	DN <sub>1</sub>	L <sub>1</sub> [mm]	L <sub>2</sub> [mm]	x	Art.-Nr. Art.No./no d'art.	Art.-Nr. Art.No./no d'art.
25	15	75	75	100	15.20130.0100	15.20340.0100
40	25	100	75	100	15.20150.0100	15.20350.0100
50	25	100	75	100	15.20160.0100	15.20360.0100
50	25	150	75	100	15.20190.0100	15.20370.0100
70	40	150	100	100	15.20180.0100	15.20390.0100

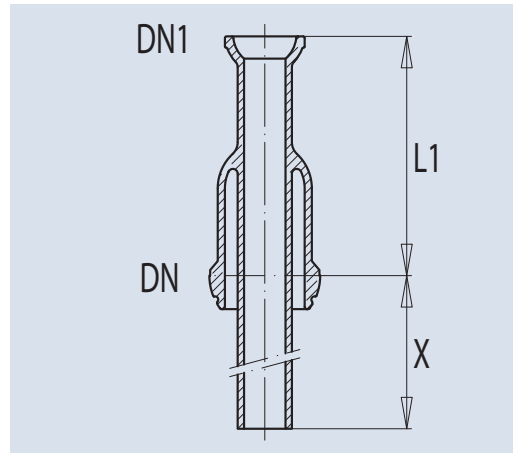

Vorzugsreihe  
Preferred series  
Série préférentielle

15. ... = blank/plain/nu  
(16. ... = beschichtet/coated/revêtu)

\* DN mit \* bezeichnet ist nur mit Schliiffart 3  
lieferbar!  
\* DN indicated with \* can be supplied with type  
of grinding 3 only!  
\* DN désigné avec \*, délivrable qu'avec le genre  
de rodage 3!

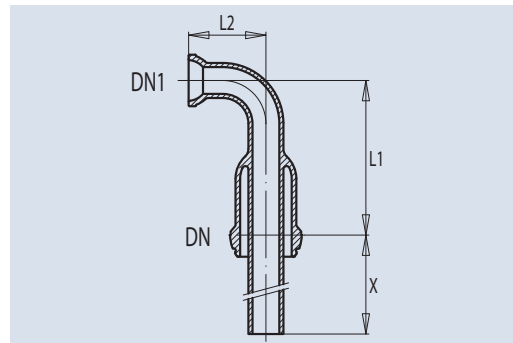

### Deutsch

Einleitrohre sind standardmässig mit den Schliiffkombinationen 1/2 und 3/2 lieferbar. Das Mass X ist im Standard 100 mm lang, was für die meisten Standardstutzen und Deckelplatten eine genügende Eintauchtiefe ist. Für spezielle Anwendungen/Gegebenheiten kann dieses Mass auch verlängert werden. Hierbei ist die Artikelnummer:

Beispiel 15.20160.0XXX

mit der entsprechenden Länge zu ergänzen.

### Schliiffarten

- 1 = «büchiflex»-Kugel
- 2 = «büchiflex»-Pflanne
- 3 = «büchiglas»-Planschliff

### English

Dip pipes are in the standard version available with grinding combination 1/2 and 3/2. The length X is in the standard version 100 mm long, which is sufficient as dip depth for most of the standard sockets and cover plates. This length can be increased for special applications /situations.

In this case please is the part number:

example: 15.20160.0XXX

to replace with the needed length in mm.

### Types of grinding

- 1 = «büchiflex» ball
- 2 = «büchiflex» socket
- 3 = «büchiglas» plane joint

### Français

Tubes d'introduction sont disponibles comme standard avec les rodages 1/2 et 3/2. La longueur X dans le standard est 100 mm, qui est assez comme profondeur d'introduction pour la majorité des raccords et couvercles des réacteurs/récipients. Cette longueur peut être rallongée pour applications/situations spéciaux. Dans ce cas ce numéro d'article:

exemple: 15.20160.0XXX

est à remplacer avec la longueur désirée en mm.

### Genres de rodage

- 1 = rodage mâle «büchiflex»
- 2 = rodage femelle «büchiflex»
- 3 = rodage plan «büchiglas»

## Einleitrohr 87° DN 15-100

## 87° Dip pipe DN 15-100

## Tube d'introduction 87° DN 15-100

DN	DN <sub>1</sub>	L <sub>1</sub> [mm]	L <sub>2</sub> [mm]	x		
					Art.-Nr. Art.No./no d'art.	Art.-Nr. Art.No./no d'art.
25	15	75	75	100	15.20137.0100	15.30337.0100
40	25	100	75	100	15.20157.0100	15.20357.0100
50	25	100	75	100	15.20167.0100	15.20367.0100
50	25	150	75	100	15.20177.0100	15.20377.0100
70	40	150	100	100	15.20187.0100	15.20387.0100
100	25	150	75	100	15.20197.0100	15.20397.0100

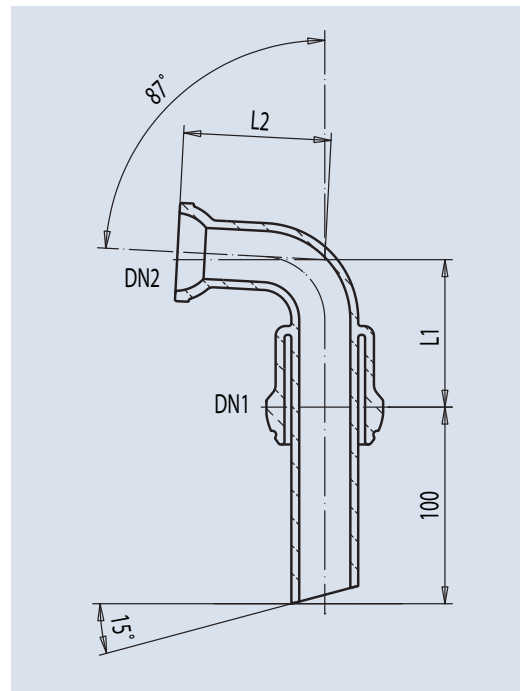

Vorzugsreihe  
Preferred series  
Série préférentielle

15. ... = blank/plain/nu  
(16. ... = beschichtet/coated/revêtue)



### Deutsch

Einleitrohre 87° sind standardmässig mit den Schliffkombinationen 1/2 und 3/2 lieferbar. Das Mass X ist im Standard 100 mm lang, was für die meisten Standardstutzen und Deckelplatten eine genügende Eintauchtiefe ist. Für spezielle Anwendungen/Gegebenheiten kann dieses Mass auch verlängert werden. Hierbei ist die Artikelnummer:

Beispiel 15.20167.0XXX

mit der entsprechenden Länge zu ergänzen.

#### Schliffarten

- 1 =  «büchiflex»-Kugel
- 2 =  «büchiflex»-Pfanne
- 3 =  «büchiglas»-Planschliff

### English



Dip pipes 87° are in the standard version available with grinding combination 1/2 and 3/2. The length X is in the standard version 100 mm long, which is sufficient as dip depth for most of the standard sockets and cover plates. This length can be increased for special applications / situations.

In this case please is the part number:

example: 15.20167.0XXX

to replace with the needed length in mm.

#### Types of grinding

- 1 =  «büchiflex» ball
- 2 =  «büchiflex» socket
- 3 =  «büchiglas» plane joint



### Français

Tubes d'introduction 87° sont disponibles comme standard avec les rodages 1/2 et 3/2. La longueur X dans le standard est 100 mm, qui est assez comme profondeur d'introduction pour la majorité des raccords et couvercles des réacteurs/réceptacles. Cette longueur peut être rallongée pour applications/situation spéciaux. Dans ce cas ce numéro d'article:

exemple: 15.20167.0XXX

est à remplacer avec la longueur désirée en mm.

#### Genres de rodage

- 1 =  rodage mâle «büchiflex»
- 2 =  rodage femelle «büchiflex»
- 3 =  rodage plan «büchiglas»

## Einleitrohr abgewinkelt, DN 15-70

## Dip pipe, angled

## Tube d'introduction, coudé

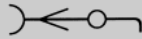

DN	DN <sub>1</sub>	L [mm]	Art.-Nr. Art. No./no d'art.
25	15	100	15.20400. ...
40	25	100	15.20410. ...
50	25	150	15.20420. ...
70	40	150	15.20430. ...
70	50	150	15.20440. ...
100	50	150	15.20450. ...
100	70	150	15.20460. ...

Vorzugsreihe  
Preferred series  
Série préférentielle

### Beispiel:/Ordering example:/Exemple de commande:

15	20420	0100	• X = 100 mm
----	-------	------	--------------

Einleitrohr abgewinkelt  
DN 50/25

• Dip pipe, angled DN 50/25  
Tube d'introduction coudé  
DN 50/25

• 15. ... = blank/plain/nu  
(16. ... = beschichtet/coated/revêtue)

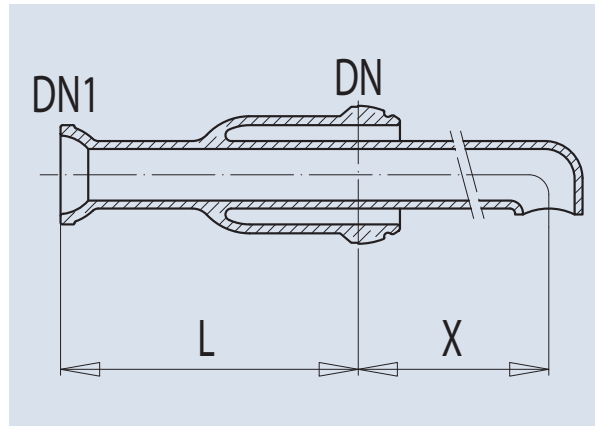

### Deutsch

Diese Einleitrohre werden standardmässig mit der Schliiffkombination 1/2 ausgerüstet. Das Mass X muss den gegebenen Verhältnissen angepasst werden. Die Art.-Nr. ist dabei mit der gewünschten Länge in mm zu ergänzen.

### Schliffarten

- 1 = «büchiflex»-Kugel
- 2 = «büchiflex»-Pfanne

### English

The standard feed pipes are provided with the 1/2 grinding combination. Dimension X must be adjusted to suit the prevailing conditions. Add the required length in mm to the article number.

### Types of grinding

- 1 = «büchiflex» ball
- 2 = «büchiflex» socket

### Français

Ces tubes d'introduction sont équipées en série avec la combinaison de rodages 1/2. La cote X doit être adaptée aux conditions données. Le numéro d'article doit alors être complété avec la longueur souhaitée en mm.

### Genres de rodage

- 1 = rodage mâle «büchiflex»
- 2 = rodage femelle «büchiflex»

# Gaseinleitrohr DN 15-70

## Gas inlet tube

## Tube d'introduction de gaz

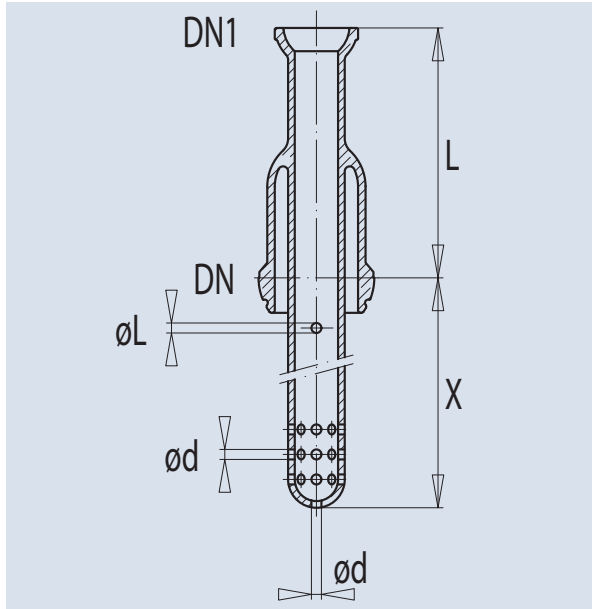

### Bestellbeispiel:/Ordering example:/Exemple de commande:

15 | 20720 | 0100 → X = 100 mm

- Gaseinleitrohr DN 50/25 für Gaseinleitung
- Gas inlet tube DN 50/25
- Tube d'introduction de gaz DN 50/25
- 15. ... = blank/plain/nu (16. ... = beschichtet/coated/revêtue)

### Deutsch

Dieses Bauteil wird als Gaseinleitrohr und Einleitrohr für Flüssigkeiten unter dem Flüssigkeitsspiegel eingesetzt. Es wird zwischen zwei Ausführungen unterschieden.

- **Ausführung G** für Gaseinleitung
  - **Ausführung F** für Flüssikeitseinleitung (mit Belüftungsloch øL)
- Das Mass X muss den gegebenen Verhältnissen angepasst werden. Die Art.-Nr. ist dabei mit der gewünschten Länge in mm zu ergänzen.

### Schliffarten

- 1 = «büchiflex»-Kugel
- 2 = «büchiflex»-Pfanne

### English

This component is used as an inlet tube for gases and liquids under the surface of the liquid. There are two versions:

- **Version G** for gas injection
  - **Version F** for liquid injection (with a venting hole diameter L)
- Dimension X must be adjusted to suit requirements. Add the required length in mm to the article number.

### Types of grinding

- 1 = «büchiflex» ball
- 2 = «büchiflex» socket

### Français

Cet élément est utilisé comme tube d'introduction de gaz et tube d'introduction de liquide sous le niveau de liquide. On différencie deux exécutions:

- **exécution G** pour l'introduction de gaz
- **exécution F** pour l'introduction de liquides (avec un trou d'aération øL)

La cote X doit être adaptée aux conditions données. Le numéro d'article doit alors être complété par la longueur souhaitée en mm.

### Genres de rodage

- 1 = rodage mâle «büchiflex»
- 2 = rodage femelle «büchiflex»

n = Anzahl Löcher (ød)/number of holes (diameter d)/nombre de trous (ød)  
 \* = nur bei Ausf. F!/version F only/uniquement pour l'exécution F!

### Vorzugsreihe/Preferred series/Série préférentielle

DN	DN <sub>1</sub>	L [mm]	Ø d [mm]	n [mm]	Ausf./type G/exéc. Art.-Nr. Art. No./no d'art.	* øL	Ausf./type F/exéc. Art.-Nr. Art. No./no d'art.
25	15	100	3	25	15.20700. ...	3	15.20900. ...
40	25	100	6	25	15.20710. ...	6	15.20910. ...
50	25	150	6	25	15.20720. ...	6	15.20920. ...
70	25	150	6	25	15.20730. ...	6	15.20930. ...
70	40	150	8	33	15.20740. ...	8	15.20940. ...
70	50	150	9	33	15.20750. ...	9	15.20950. ...
100	25	150	6	25	15.20760. ...	6	15.20960. ...
100	40	150	8	33	15.20770. ...	8	15.20970. ...
100	50	150	9	33	15.20780. ...	9	15.20980. ...
100	70	150	12	33	15.20790. ...	12	15.20990. ...



## Brause waagrecht

## Sprinkler head horizontal

## Douche horizontale

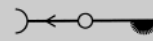
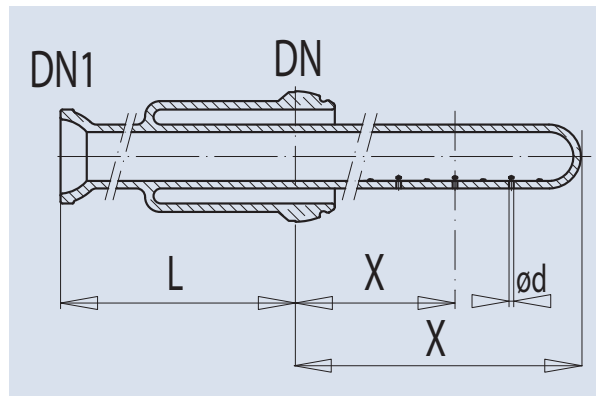

DN	DN <sub>1</sub>	[DN] Kolonne	L	X	Ø d [mm]	n	Art.-Nr. Art. No./no d'art.
50	25	50	150	120	1.5	7	15.20506.0120
50	25	70	150	150	3	12	15.20501.0150
50	25	100	150	165	3	17	15.20502.0165
50	25	150	150	240	3	17	15.20503.0240
50	25	200	150	255	3	22	15.20504.0255
50	25	300	150	380	3	27	15.20505.0380
70	40	200	150	255	4	22	15.20511.0255
70	40	300	150	380	4	24	15.20512.0380
70	40	400	150	480	4	24	15.20513.0480
70	40	450	150	525	4	24	15.20514.0525
70	40	600	150	655	4	24	15.20515.0655

n = Anzahl Brauselöcher / number of sprinkler holes / nombre des trous douche

15. ... = blank/plain/nu

(16. ... = beschichtet/coated/revêtue)

### Deutsch

Diese Brausen werden waagrecht in die entsprechenden Seitenstutzen von Kolonnen eingebaut. Sie dienen der gleichmäßigen Verteilung der Flüssigkeit über die Füllkörper/Packungen der Kolonne. Die Anzahl, die Größe und die Verteilung der Öffnungen in der Brause sind hierbei entscheidend für die korrekte Flüssigkeitsverteilung und somit Funktion der Kolonne.

#### Schliffarten

1 = «büchiflex»-Kugel

2 = «büchiflex»-Pfanne

### English

These sprinkler heads are built in horizontally at side connection of columns. They serve to evenly distribute liquids over the column packing. The number, the diameter and the distribution of holes are a deciding factor for even liquid distribution and correct functioning of the column.

#### Types of grinding

1 = «büchiflex» ball

2 = «büchiflex» socket

### Français

Ces têtes de douche sont à installer horizontalement, fixer dans un raccord latéral de la colonne. Ils servent à la distribution régulière du liquide au-dessus de la garniture. Le nombre, le diamètre et la distribution des trous sont importants pour la distribution régulière du liquide et le fonctionnement correct de la colonne.

#### Genres de rodage

1 = rodage mâle «büchiflex»

2 = rodage femelle «büchiflex»

## Tropfgefäß

## Dropping glass

## Pipette

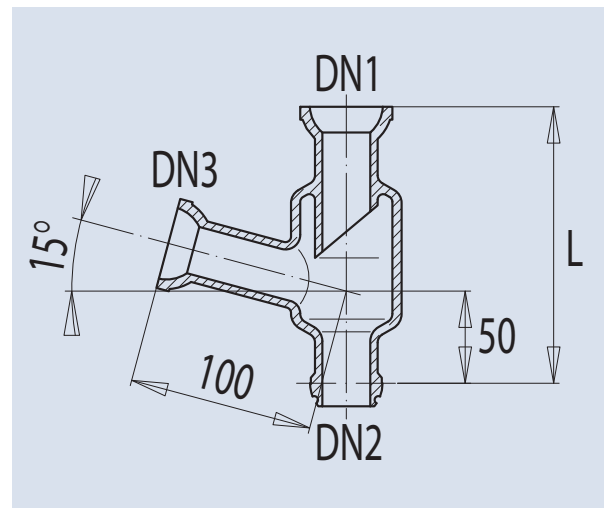

DN <sub>1</sub>	DN <sub>2</sub> [mm]	DN <sub>3</sub> [mm]	L [mm]	Bestell-Nr. Art. No./no de cde.
25	25	25	150	15.22500.0000
40	40	25	200	15.22510.0000
50	50	25	250	15.22520.0000



### Deutsch

Dieses Bauteil wird senkrecht in Rohrleitungen DN 25 eingebaut. Der Seitenstutzen DN<sub>3</sub> dient dem Einbau eines Thermometers. Durch Ausrichten des Messfühlers auf die Tropfspitze kann auch bei geringsten Durchflussmengen die Temperatur gemessen werden.



#### Schliffarten

- 1 =  «büchiflex»-Kugel
- 2 =  «büchiflex»-Pfanne

### English

This component is installed vertically in DN 25 tubing. A thermometer is installed in DN<sub>3</sub> side arm. The temperature can be measured at very low flow-rates when the measuring sensor is correctly aligned with the dropper.



#### Types of grinding

- 1 =  «büchiflex» ball
- 2 =  «büchiflex» socket

### Français

Cet élément est monté verticalement dans les conduites DN 25. Le raccord latéral DN<sub>3</sub> sert au montage d'un thermomètre. Par l'alignement de la sonde de mesure sur la pointe de la goutte, il est possible de mesurer la température dans le cas de débits minimums.

#### Genres de rodage

- 1 =  rodage mâle «büchiflex»
- 2 =  rodage femelle «büchiflex»

# Schlaucholive «büchiflex» DN 15-50

## Flexible tube connection «büchiflex»

### Raccord à olive «büchiflex»

DN	L [mm]	a [mm]	Art.-Nr. Art. No./no d'art.
15	70	20	10.05300. ...
25	85	20	10.05305. ...
25	85	26	10.05310. ...
40	110	40	10.05320. ...
50	120	53	10.05330. ...

Ausf./type/exéc. X

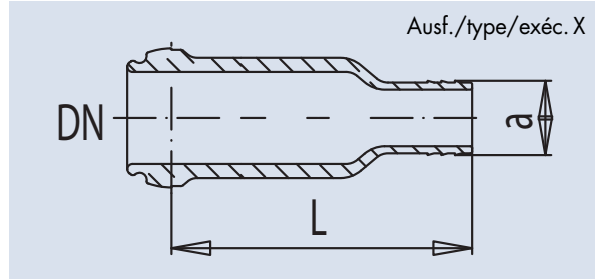

DN	L <sub>1</sub> [mm]	L <sub>2</sub> [mm]	a [mm]	Art.-Nr. Art. No./no d'art.
15	75	85	20	10.05400. ...
25	75	100	20	10.05405. ...
25	75	100	26	10.05410. ...
40	100	110	40	10.05420. ...
50	150	140	53	10.05430. ...

Ausf./type/exéc. Y

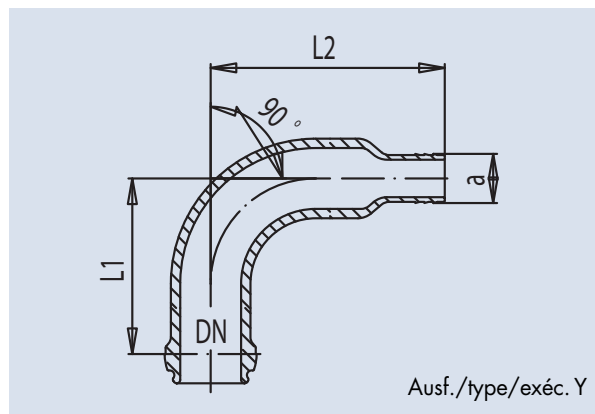

**Hinweis:** Abweichungen vom Oliven-Durchmesser (a) sind zulässig. Sonderabmessungen sind bei der Bestellung anzugeben.

**Note:** Deviations from the diameter (a) of the flexible tube connection are permissible. State non-standard dimensions when ordering.

**Remarque:** Des écarts du diamètre des olives (a) sont admissibles. Les dimensions spéciales doivent être indiquées à la commande.

### Kenn-Nr. für Schliffart Code number for type grinding Indice du genre de rodages

Schliffart 2  
Types of grinding 2  
Genre de rodage 2

10	05410	0020	0010	(1)
			0020	(2)
			0040	(3)

Schlaucholive «büchiflex», DN 25/90°  
Flexible tube connection «büchiflex», DN 25/90°  
Raccord à olive «büchiflex», DN 25/90°

• 10. ... = blank/plain/nu  
(11. ... = beschichtet/coated/revêtue)

Vorzugsreihe  
Preferred series  
Série préférentielle

### Deutsch

Die Bestell-Nr. wird aus Art.-Nr. und Kenn-Nr. der gewünschten Schliffkombination gemäss Bestellbeispiel gebildet.

#### Schliffarten

- 1 = «büchiflex»-Kugel
- 2 = «büchiflex»-Pfanne
- 3 = «büchiglas»-Planschliff

### English

The order number is formed from the article number and the code number of the desired type of grinding in accordance with ordering example.

#### Types of grinding

- 1 = «büchiflex» ball
- 2 = «büchiflex» socket
- 3 = «büchiglas» plane joint

### Français

Le numéro de commande est constitué du numéro d'article et de l'indice du rodage souhaité selon l'exemple de commande.

#### Genres de rodage

- 1 = rodage mâle «büchiflex»
- 2 = rodage femelle «büchiflex»
- 3 = rodage plan «büchiglas»

## Planschliff-Rohr «PS» DN 15-200

### Plane joint tube «PS»

### Conduite à rodage plan «PS»

DN	L min. [mm]	L max. [mm]	Art.-Nr. Art. No./no d'art.
15	50	3000	10.06015. ...
25	60	3000	10.06025. ...
32	65	3000	10.06032. ...
40	70	3000	10.06040. ...
50	80	3000	10.06050. ...
60	85	3000	10.06060. ...
70	90	3000	10.06070. ...
80	100	3000	10.06080. ...
100	110	3000	10.06100. ...
115	120	3000	10.06115. ...
125	130	3000	10.06125. ...
150	150	3000	10.06150. ...
200	175	2000	10.06200. ...

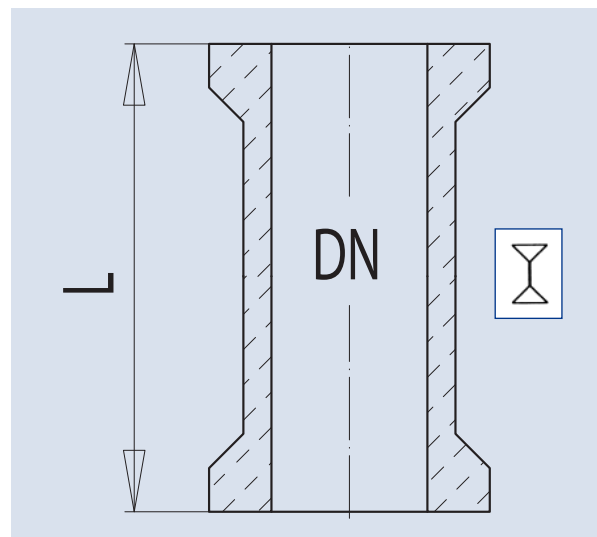

#### Deutsch

Planschliff-Rohre «PS» werden vor allem als Schaugläser eingesetzt. Innerhalb der minimalen und maximalen Herstellungslängen kann die Länge den jeweiligen Bedürfnissen angepasst werden. Die Art.-Nr. ist dabei mit der gewünschten Länge in mm gemäss Bestellbeispiel zu ergänzen.

#### English

Plane joint tubes «PS» are mainly used as sight glasses. The length can be adapted to individual requirements within the minimum and maximum manufacturing lengths. Add the required length in mm to the article number in accordance with the ordering example.

#### Français

Les conduites à rodage plan «PS» sont avant tout utilisées comme regards. La longueur peut être adaptée aux exigences correspondantes à l'intérieur des longueurs de fabrication minimales et maximales. Le numéro d'article doit alors être complété par la longueur souhaitée en mm selon l'exemple de commande.

#### Bestellbeispiel:

#### Ordering example:

#### Exemple de commande:

10	06050	0500	• L = 500 mm
----	-------	------	--------------

• Planschliff-Rohr «PS», DN 50  
 • Plane joint tube «PS», DN 50  
 • Conduite à rodage plan «PS», DN 50  
 • 10. ... = blank/plain/nu  
 (11. ... = beschichtet/coated/revêtue)

## Blindverschluss «KF» DN 15-300

### Plug «KF»

### Fermeture dissimulée «KF»

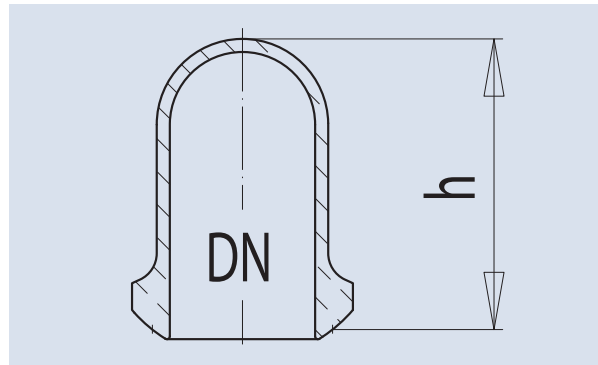

#### Deutsch

Blindverschlüsse «KF» sind bis DN 300 in den Schliffarten 5 und 6 lieferbar.

#### Schliffarten

5 =  $\rightarrow$  KF-Kugel  
6 =  $\curvearrowright$  KF-Pfanne

#### English

«KF» plugs are available up to DN 300 in types of grinding 5 and 6.

#### Types of grinding

5 =  $\rightarrow$  KF ball  
6 =  $\curvearrowright$  KF socket

#### Français

Les fermetures dissimulées «KF» sont livrables jusqu'à DN 300 dans les genres de rodages 5 et 6.

#### Genres de rodage

5 =  $\rightarrow$  rodage mâle KF  
6 =  $\curvearrowright$  rodage femelle KF

DN	h <sub>≈</sub> [mm]		
		↓	┆
		Bestell.-Nr. ** Art. No./no de cde	Bestell.-Nr. ** Art. No./no de cde
15	50-85	15.14600.0000	15.14700.0000
25	50-85	15.14610.0000	15.14710.0000
40	65-110	15.14620.0000	15.14720.0000
50	70-115	15.14630.0000	15.14730.0000
80	70-95	15.14640.0000	15.14740.0000
100	90-95	15.14650.0000	15.14750.0000
150	115	15.14660.0000	15.14760.0000
200	120	15.14670.0000	15.14770.0000
300	170	15.14680.0000	15.14780.0000

## Rohr «KF» DN 15-300

## Tube «KF»

## Conduite «KF»

DN	L min. [mm]	L max. [mm]	Art.-Nr. Art. No./no d'art.
15	75	3000	10.07015. ...
25	75	3000	10.07025. ...
40	100	3000	10.07040. ...
50	100	3000	10.07050. ...
80	125	3000	10.07080. ...
100	125	3000	10.07100. ...
150	150	3000	10.07150. ...
200	150	2000	10.07200. ...
300	200	2000	10.07300. ...

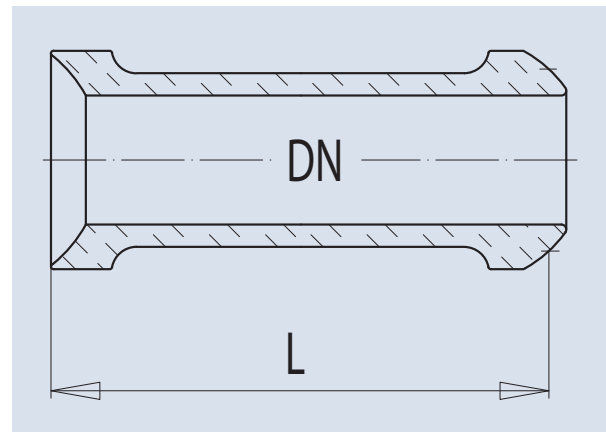

### Deutsch

«büchiglasuster» liefert auch Rohre «KF», identisch mit den Normen von «Schott». Ebenso ist Zubehör, wie z. B. Schellenverbindungen und Kragendichtungen «KF», ab Lager lieferbar. Innerhalb der minimalen und maximalen Herstellungslängen kann die Länge den jeweiligen Bedürfnissen angepasst werden. Die Art.-Nr. ist dabei mit der gewünschten Länge in mm gemäss Bestellbeispiel zu ergänzen.

### Schliffarten

- 5 = KF-Kugel  
 6 = KF-Pfanne

### English

«büchiglasuster» also supplies tubes «KF» which are identical to the «Schott» standards. Such accessories as backing flanges and collar gaskets «KF» can be supplied ex stock. The length can be adapted to individual requirements within the minimum and maximum manufacturing lengths. Add the required length in mm to the article number in accordance with the ordering example.

### Types of grinding

- 5 = KF ball  
 6 = KF socket

### Français

«büchiglasuster» fournit également des conduites «KF» identiques aux normes de «Schott». Les accessoires comme par exemple les raccordements à brides et les joints à collerette «KF» sont également disponibles du stock. La longueur peut être adaptée aux exigences correspondantes à l'intérieur des longueurs de fabrication minimales et maximales. Le numéro d'article doit alors être complété par la longueur souhaitée en mm selon l'exemple de commande.

### Genres de rodage

- 5 = rodage mâle KF  
 6 = rodage femelle KF

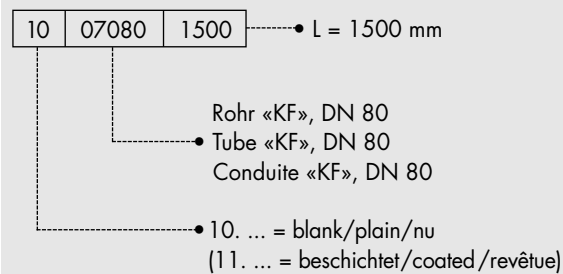

### Bestellbeispiel: Ordering example: Exemple de commande:



## Bogen «KF» DN 200-300

## Elbow «KF»

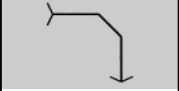
## Coude «KF»

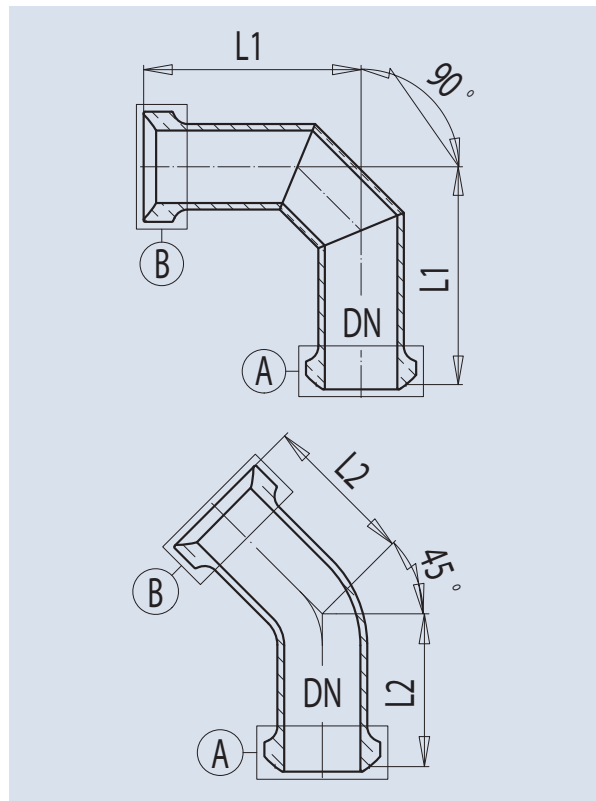

DN	L <sub>1</sub> [mm]	L <sub>2</sub> [mm]		
			Bestell.-Nr. Art. No./no de cde	Bestell.-Nr. Art. No./no de cde
200	300	200	15.10000.0000	15.10100.0000
300	400	200	15.10010.0000	15.10110.0000



### Deutsch

Bogen «KF» DN 200-300 werden standardmässig mit KF-Kugel/Pfanne und Winkel 90° und 45° geliefert.



#### Schliffarten

- 5 =  KF-Kugel  
6 =  KF-Pfanne

### English

«KF» elbows from DN 200 to DN 300 are supplied with KF ball/socket and angles of 90° and 45° as standard features.



#### Types of grinding

- 5 =  KF ball  
6 =  KF socket

### Français

Les coudes «KF» DN 200-300 sont fournis avec des raccords mâle/femelle KF et des angles à 90° et 45°.

#### Genres de rodage

- 5 =  rodage mâle KF  
6 =  rodage femelle KF

## T-Stück «KF» DN 200-300

### Tee «KF»

### Élément en T «KF»

DN	L [mm]	Bestell.-Nr. Art. No./no de cde	Bestell.-Nr. Art. No./no de cde
200	300	15.10200.0000	15.10300.0000
300	400	15.10210.0000	15.10310.0000

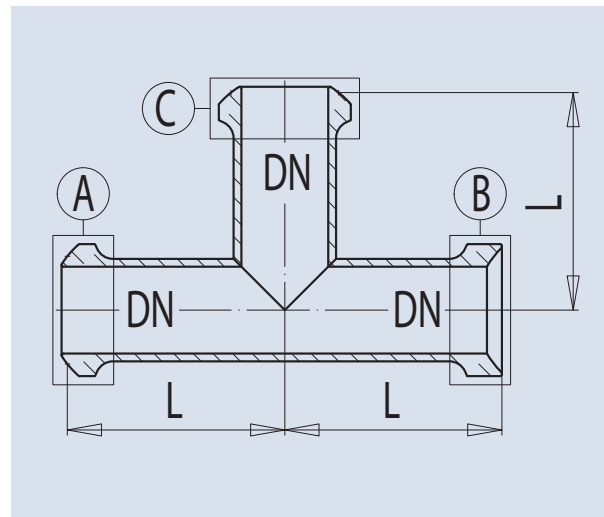

#### Deutsch

T-Stücke «KF» DN 200-300 werden standardmässig mit KF-Kugeln/Pfanne in zwei Ausführungen geliefert.

#### Schliffarten

- 5 = → KF-Kugel  
6 = ↗ KF-Pfanne

#### English

«KF» tees from DN 200 to DN 300 are supplied in two standard versions with KF ball/socket.

#### Types of grinding

- 5 = → KF ball  
6 = ↗ KF socket

#### Français

Les éléments T «KF» DN 200-300 sont fournis en série avec des raccords mâle/femelle KF dans deux exécutions.

#### Genres de rodage

- 5 = → rodage mâle KF  
6 = ↗ rodage femelle KF



## T-Stück reduziert «KF» DN 200-600

### Reducing tee «KF»

### Élément en T réducteur «KF»

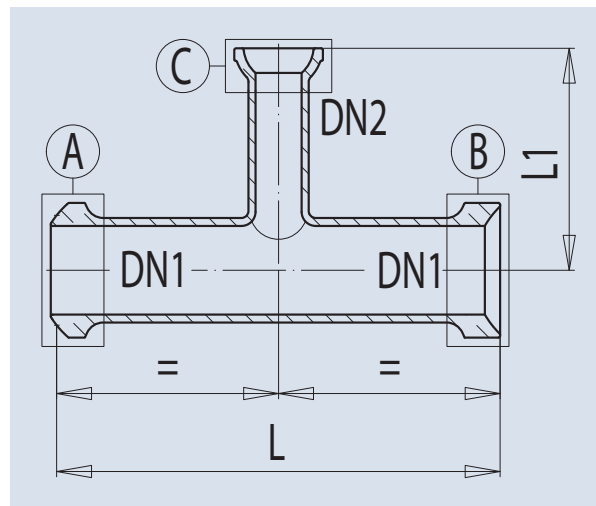

#### Deutsch

T-Stücke DN 200-600 mit reduziertem Abgang sind bis DN 300 in zwei Grundausführungen lieferbar. Die Stutzen A + B werden dabei mit KF-Kugel/Pfanne respektive mit KF-Planschliff/Planschliff ausgerüstet.

Ab DN 400 sind die Stutzen A + B nur mit KF-Planschliff lieferbar.

Der Stutzen C kann in nachstehend aufgeführten Schlifffarten geliefert werden.

Die Bestell-Nr. ist dabei mit der gewünschten Schlifffart gemäss Bestellbeispiel zu ergänzen.

#### English

Tees from DN 200 to DN 600 with a reduced leg are available in two basic versions up to DN 300. Legs A + B are provided with a KF ball/socket or with a KF plane/plane joint.

From DN 400, legs A + B are available only with a KF plane joint.

Leg C is available in the following types of grinding.

Add the required type of grinding to the order number as shown in the ordering example.

#### Français

Les éléments en T DN 200–600 à départ réduit sont livrables jusqu'à DN 300 dans deux exécutions de base. Les raccords A + B sont alors équipés de raccords mâle/femelle KF respectivement de rodages plans/rodages plans K. A partir de DN 400, les raccords A + B ne sont pas livrables qu'avec un rodage plan KF. Le raccord C peut être fourni dans les genres de rodages mentionnés ci-dessous.

Le numéro de commande doit être complété par le genre de rodage souhaité selon l'exemple de commande.

#### Schlifffarten

- 1 = «büchiflex»-Kugel
- 2 = «büchiflex»-Pfanne
- 3 = «büchiglas»-Planschliff
- 4 = KF-Planschliff
- 5 = KF-Kugel
- 6 = KF-Pfanne

#### Types of grinding

- 1 = «büchiflex» ball
- 2 = «büchiflex» socket
- 3 = «büchiglas» plane joint
- 4 = KF plane joint
- 5 = KF ball
- 6 = KF socket

#### Genres de rodage

- 1 = rodage mâle «büchiflex»
- 2 = rodage femelle «büchiflex»
- 3 = rodage plan «büchiglas»
- 4 = rodage mâle KF
- 5 = rodage mâle KF
- 6 = rodage femelle KF

#### Bestellbeispiel: Ordering example: Exemple de commande:

15	11120	9999
----	-------	------

T-Stück reduziert «KF» DN 300/50  
 • Reducing tee «KF» DN 300/50  
 Élément en T réducteur «KF» DN 300/50

• 15. ... = blank/plain/nu  
 (11. ... = beschichtet/coated/revêtue)

\*\* Gewünschte Schlifffart für Stutzen C  
 \*\* Desired type of grinding for nozzle C  
 \*\* Genre de rodage souhaité pour le raccord C

C = 2 («büchiflex»-Pfanne)  
 C = 2 («büchiflex» socket)  
 C = 2 (rodage femelle «büchiflex»)

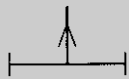
DN <sub>1</sub>	DN <sub>2</sub>	L [mm]	L <sub>1</sub> [mm]		
				Bestell.-Nr. ** Art. No./no de cde	Bestell.-Nr. ** Art. No./no de cde
<b>200</b>	25	200	175	15.10500.9999	15.11000.9999
	40	250	175	15.10510.9999	15.11010.9999
	50	250	175	15.10520.9999	15.11020.9999
	70	300	175	15.10530.9999	15.11030.9999
	80	300	175	15.10540.9999	15.11040.9999
	100	300	200	15.10550.9999	15.11050.9999
	150	400	225	15.10560.9999	15.11060.9999
<b>300</b>	25	300	225	15.10600.9999	15.11100.9999
	40	400	225	15.10610.9999	15.11110.9999
	50	400	250	15.10620.9999	15.11120.9999
	70	400	250	15.10630.9999	15.11130.9999
	80	400	250	15.10640.9999	15.11140.9999
	100	400	250	15.10650.9999	15.11150.9999
	150	500	275	15.10660.9999	15.11160.9999
	200	500	300	–	15.11170.9999
<b>400</b>	70	400	300	–	15.11200.9999
	80	400	300	–	15.11210.9999
	100	400	300	–	15.11220.9999
	150	500	325	–	15.11230.9999
	200	500	325	–	15.11240.9999
<b>450</b>	70	400	325	–	15.11300.9999
	80	400	325	–	15.11310.9999
	100	400	350	–	15.11320.9999
	150	500	350	–	15.11330.9999
	200	500	350	–	15.11340.9999
<b>600</b>	70	600	375	–	15.11400.9999
	80	600	375	–	15.11410.9999
	100	600	400	–	15.11420.9999
	150	600	425	–	15.11430.9999
	200	600	425	–	15.11440.9999
	300	800	500	–	15.11450.9999

\*\* Die Bestell-Nr. ist mit der gewünschten Schliffart für den Stutzen C zu ergänzen.  
Add the required type of grinding for leg C to the order number.  
Le numéro de commande doit être complété par le genre de rodage souhaité pour le raccord C.

Vorzugsreihe  
Preferred series  
Série préférentielle



## KEN KIMBLE (Reactor Vessels) Ltd

85 Thomas Way, Lakesview International Business Park  
Hersden, Canterbury, Kent. CT3 4NH  
Tel: 01227 710274 Fax: 01227 258840  
Email: [general@kenkimble.co.uk](mailto:general@kenkimble.co.uk) Web: [www.kenkimble.com](http://www.kenkimble.com)



**büchiglasuster**  
Pilot Plant and Reactor Systems  
switzerland