

specifications:

PHASE	STEP ANGLE	RATED VOLTAGE	CURRENT /PHASE	RESISTANCE /PHASE	INDUCTANCE /PHASE	HOLDING TORQUE	ROTOR INERTIA	WEIGHT
	DEG/STEP	V	A	ohms	mH	Nm	gcm ²	Kg
unipolar	1.8	6.6	1.0	6.6	8.2	0.7	275	0.65
bipolar(s)	1.8	9.24	0.7	13.2	32.8	1	275	0.65
bipolar(p)	1.8	4.62	1.4	3.3	8.2	1	275	0.65

Wiring Diagram:

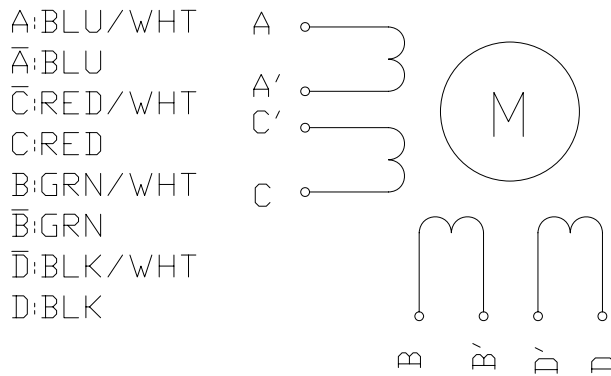

Rotation:

CW DIRECTION	STEP	A C'	C A'	B D'	D B'
↓	1	+		+	
	2		+	+	
	3		+		+
	4	+			+
	1	+		+	

CW direction, see from the shaft end

Dimension:

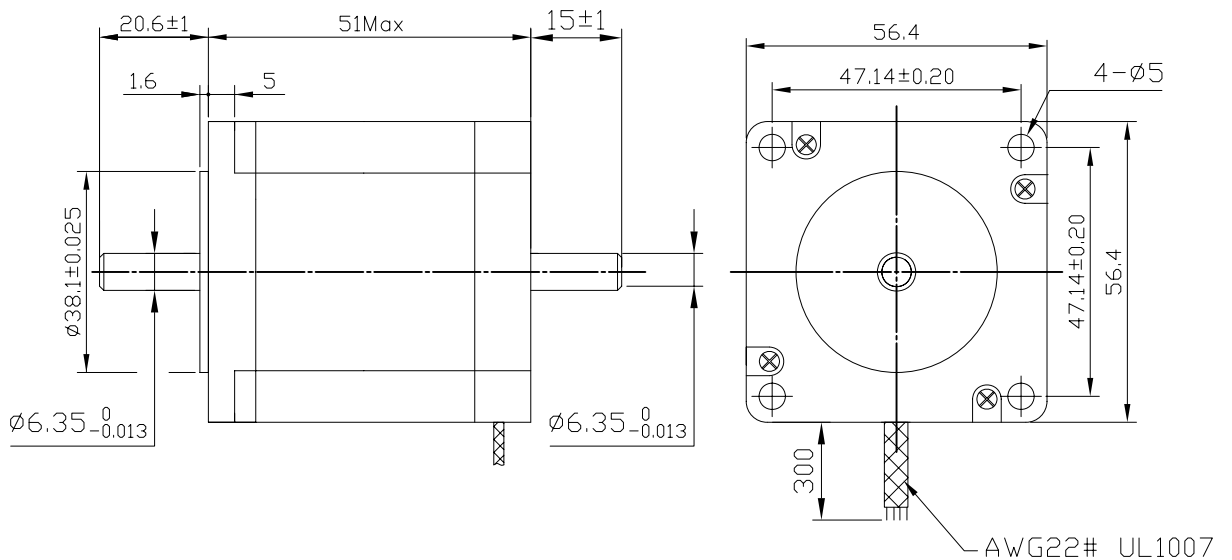

DESIGN	DATE	P/N.
REV	ECN NO.	DESCRIPTION
DRN	APP'D	DATE
CHECK		TITLE
APPD		Specifications
SCALE	OF	USED ON
SHEET	OF	FL57STH51-1008B
		DWG NO. FX3.162. SS
		REV
		MCP Ltd

UNLESS OTHERWISE SPECIFIED
 TOLERANCES
 DECIMALS: ANGULAR:
 .x ±0.5 ±0°30'
 .xx ±0.25
 .xxx ±0.1
 UNIT: mm
 DO NOT SCALE DRAWING

MATERIAL
 THIRD ANGLE PROJECTION

CHECK
 APPD
 SCALE
 SHEET OF