



Datasheet

Goodix

GT9113

The information contained in this document has been carefully researched and is, to the best of our knowledge, accurate. However, we assume no liability for any product failures or damages, immediate or consequential, resulting from the use of the information provided herein. Our products are not intended for use in systems in which failures of product could result in personal injury. All trademarks mentioned herein are property of their respective owners. All specifications are subject to change without notice.

GT9113

Window 8 capacitor touch chip

Rev.04—2013-12-30

==== Disclaimer =====

Application information and similar contents concerning the device in this publication are only intended for you and they may be substituted by updated information. It is your responsibility to ensure its application complies with technical specifications. GOODIX makes no representation or guarantee for this information, either express or implied, written or verbal, statutory or in any other manner, including but not limited to representation or guarantee for their application status, quality, performance or suitability for special purpose. GOODIX shall assume no responsibility for this information and relevant subsequences arising from use of such information. Without written approval GOODIX, it is prohibited to use GOODIX product as critical parts in any life support system. With GOODIX intellectual property protection, it is prohibited to transfer any license in any disguised manner or any other manner.

Contents

1. Overview.....	3
2. Product features.....	3
3. System chart.....	4
4. Pin definition.....	5
4.1. GT9113 pin definition.....	5
4.2. GTM802 pin definition.....	6
5. Sensor design.....	8
5.1. Sensing channel layout.....	8
5.2. Driving channel layout.....	8
5.3. Parameter requirements for sensor design.....	8
5.4. Touch-screen Homekey design.....	9
6. I2C&USB communication.....	10
6.1. I ² C communication.....	10
6.2. USB communication.....	12
6.3. GT9113 register information.....	16
a) Real-time command.....	16
b) Configuration information.....	16
7. Function description.....	21
7.1. I ² C working mode.....	21
a) Normal Mode.....	21
b) Green Mode.....	21
c) Sleep Mode.....	21
7.2. USB working mode.....	22
a) Normal Mode.....	22
b) Green Mode.....	22
c) Sleep Mode.....	22
7.3. Interrupted trigger mode.....	22
7.4. Solidifying configuration function.....	22
7.5. Automatic calibration.....	23
a) Initial calibration.....	23
b) Automatic thermal drift compensation.....	23
8. Reference circuit diagram.....	24
9. Electrical characteristics.....	26
9.1. Extreme electrical parameter.....	26
9.2. Recommended working conditions.....	26
9.3. AC characteristics.....	26
9.4. DC characteristics.....	27
10. Product packaging.....	28
10.1. GT9113 packaging.....	28
10.2. GTM802 Packaging.....	29
11. Revision Record.....	30
12. Contact Information.....	31

1. Overview

As a new generation 10-point capacitive touch solution designed for WIN8 tablets, GT9113 consists of up to 42 Driving channels and 30 Sensing channels to ensure high-precision touch for tablets.

GT9113 can simultaneously identify the real-time accurate location, motion locus and touch area of 10 touch points, and read touch information for relevant points based on MCU requirements.

2. Product features

- ◇ Built-in capacitance detection circuit and high-performance MCU
 - Touch scanning frequency: >100Hz
 - Real-time output of touch point coordinates
 - Unified software version, applicable to capacitive screens of multiple sizes
 - Flash process, supports online burning
- ◇ Capacitive screen sensor:
 - Test channel: 42(Driving channel)*30(Sensing channel)
 - Range of sizes for capacitive screen: <=10.1"
 - Support Win8 Standard Homekey design
 - Support both ITO glass and ITO film
 - Cover Lens thickness support: 0.7mm ≅ Glass ≅ 2mm / 0.5mm ≅ Acrylic ≅ 1.2mm
 - Built-in frequency hopping function, support OGS full bonding
- ◇ Environmental adaptability
 - Initializing automatic calibration
 - Automatic thermal drift compensation
 - Operating temperature: -40℃~+85℃; humidity: ≅ 95%RH
 - Storage temperature: -55℃~+125℃; humidity: ≅ 95%RH
- ◇ Communication interface
 - Standard USB, 2.0 Fullspeed communication interface
 - Standard I²C communication interface
 - Slave unit working mode
 - I²C support 2.8 ~3.3V interface level
- ◇ Response time
 - Green mode: <48ms
 - Sleep mode: <200ms
 - Initialization: <200ms
- ◇ Power voltage:

- Single power supply:
 - a) I²C solution: 2.8V ~3.3V
 - b) USB solution: 5V
- ✧ Power ripple:
 - $V_{pp} \leq 50\text{mV}$
- ✧ Packaging: GT9113:88 pins, 10mm*10mm QFN
GTM802:32 pins, 5mm*5mm QFN
- ✧ Application development support tool
 - Touch screen module parameter detection and automatic configuration parameter generation
 - Overall performance test tool for touch screen module
 - Modular production test tool
 - Reference drive code and documentary guide for main control software development

3. System chart

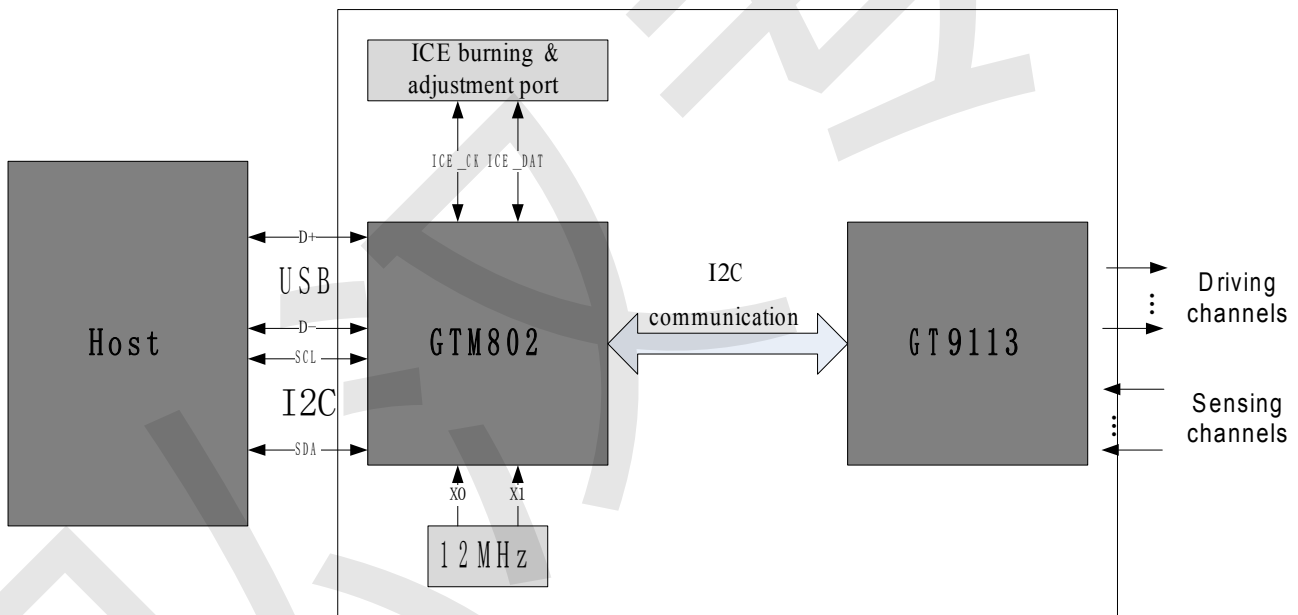

GT9113 hardware system chart

4. Pin definition

4.1. GT9113 pin definition

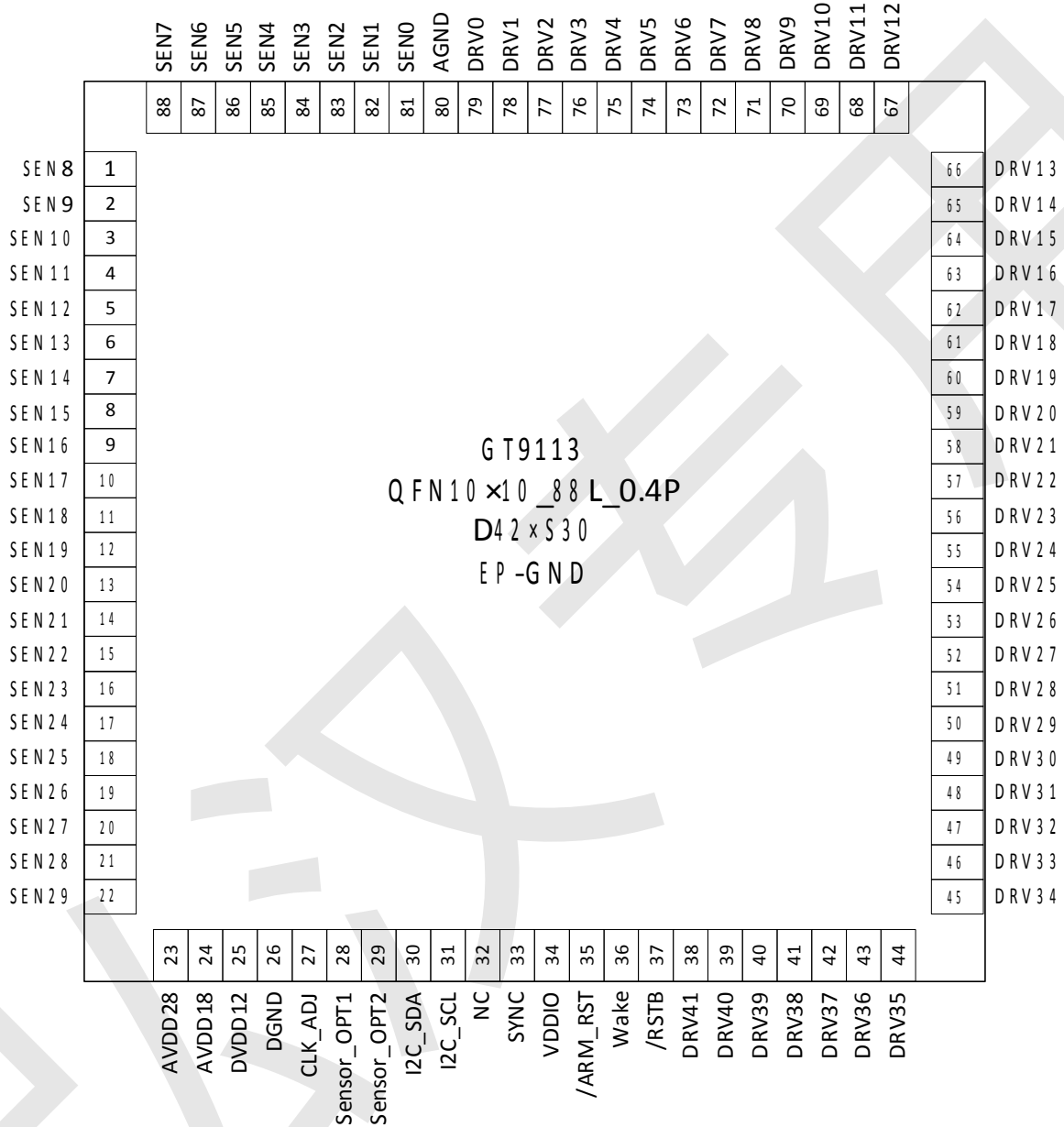

Pin No.	Name	Function description	Remarks
1~22	SENS8~SENS29	Touch analog signal input	
23	AVDD28	Analog power positive	To 2.2uF filter capacitor
24	AVDD18		To 2.2uF filter capacitor
25	DVDD12		To 2.2uF filter capacitor
26	DGND	Digital signal ground	
27	CLK_ADJ	GT9113 clock calibration pin	
28	Sensor_OPT1	Module ID port	

29	Sensor_OPT2	Module ID port (Optional)	External pull down required
30	I2C_SDA	I ² C data signal	GTM802 communication interface
31	I2C_SCL	I ² C clock signal	GTM802 communication interface
32	NC	NC	
33	SYNC	GT9113 interrupted signal output pin	
34	VDDIO	GPIO level control	To 2.2uF filter capacitor Suspend: 1.8V Connect AVDD: AVDD
35	/ARM_RST	ARM Reset control pin	
36	Wake	Wake GT9113 control pin	
37	/RSTB	GT9113 reset pin	External 10K pull up required, lower down to reset
38~79	DRV41~DRV0	Drive signal output	
80	AGND	Analog power supply ground	
81~88	SEN0~SEN7	Touch analog signal input	

4.2. GTM802 pin definition

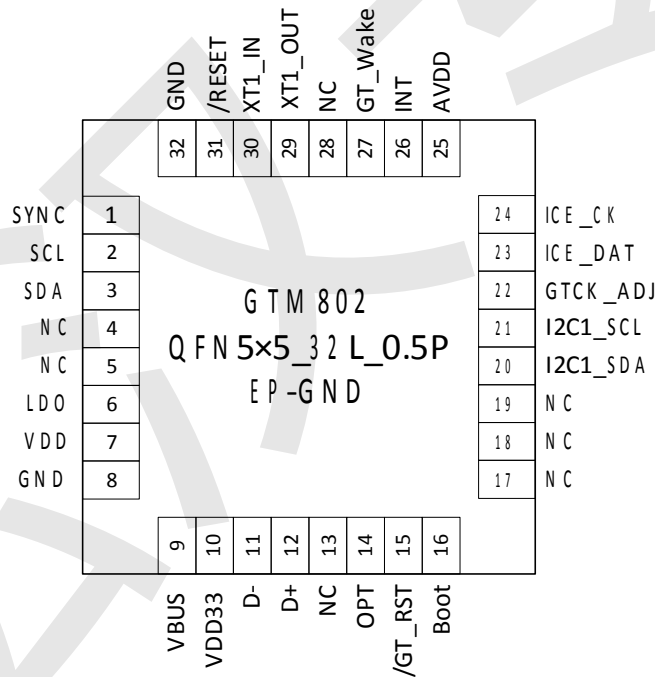

Pin No.	Name	Function description	Remarks
1	SYNC	GTM802 interrupted wake pin	GT9113 uses the pin to wake GTM802
2	SCL	I ² C clock signal	I ² C scheme master control communication interface
3	SDA	I ² C data signal	I ² C scheme master control communication interface
4	NC	NC	

5	NC	NC	
6	LDO	Built-in LDO output	Filter capacitor grounding required
7	VDD	Digital power supply	Filter capacitor grounding required
8	GND	Ground	
9	VBUS	From USB Host or USB HUB power supply	
10	VDD33	Built-in LDO decoupling capacitor connecting pin	Filter capacitor grounding required
11	D-	USB communication interface	USB scheme master control interface
12	D+	USB communication interface	USB scheme master control interface
13	NC	NC	
14	OPT	USB, I2C scheme selection	USB scheme: Suspend; I2C scheme: Short connection grounding
15	/GT_RST	Control GTM9113 reset pin	
16	Boot	Upgrading port, internal pull up	Test bonding pad reserved
17	NC	NC	
18	NC	NC	
19	NC	NC	
20	I2C1_SDA	GT9113 I2C communication data port	
21	I2C1_SCL	GT9113 I2C clock data port	
22	GTCK_ADJ	GT9113 I2C address select pin	
23	ICE_DAT	Burning port	Test bonding pad reserved
24	ICE_CK	Burning port	Test bonding pad reserved
25	AVDD	Analog circuit power supply	Filter capacitor grounding required
26	INT	Interrupted output	Master control communication interface
27	GT_Wake	Wake GT9113 output port	
28	NC	NC	
29	XTI_OUT	Crystal oscillator output pin	
30	XTI_IN	Crystal oscillator input pin	
31	/RESET	Reset	External pull up required, valid when low
32	GND	Grounding	

5. Sensor design

5.1. Sensing channel layout

SENS0~SENS29 represents 30 capacitance detection input channels directly connected with the 30 sensing ITO channels of the touch screen module. The ITO channels on the module are connected with SENS0 to SENS29 on the chip in sequence or reversed sequence. When there are fewer ITO channels than test channels on the chip, please use “Channel selector” to select channels.

- Layout example: Sensing ITO channels connected with SENS0 to SENS29 on the chip

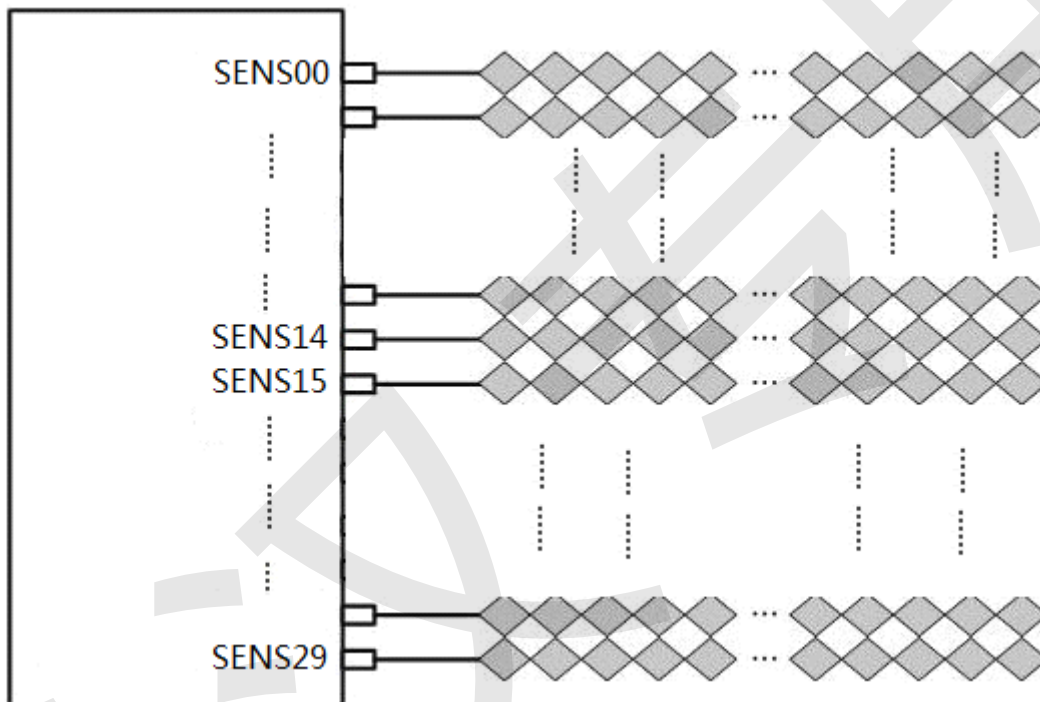

5.2. Driving channel layout

DRV0~DRV41 represents 42 drive signal output channels for capacitance detection directly connected with 42 ITO drive channels of the touch screen module. When there are fewer ITO drive channels than drive channels on the chip, please use “Channel selector” to select channels. After deciding layout mode, it is required to provide relevant register with GT9113 chips to ensure the logical position relation of drive channels is consistent with their physical position relation and make output coordinates match physical coordinates.

For more information about sensor design, please refer to specific layout guide.

5.3. Parameter requirements for sensor design

DITO

	GT9113
Drive channel wiring impedance	$\cong 3K\Omega$
Drive channel impedance	$\cong 10K\Omega$
Sensing channel wiring impedance	$\cong 10K\Omega$
Sensing channel impedance	$\cong 40K\Omega$
Node capacitor	$\cong 4pF$

SITO

	GT9113
Drive channel wiring impedance	$\cong 3K\Omega$
Drive channel impedance	$\cong 10K\Omega$
Sensing channel wiring impedance	$\cong 10K\Omega$
Sensing channel impedance	$\cong 10K\Omega$
Node capacitor	$\cong 4pF$

1. For specific Sensor Design, please refer to Goodix “Sensor Design Specifications”.
2. When metal wire is used for channel wiring, wire may become oxidated and impedance tends to become greater due to such factors as process control, thus leading to difference between different channels in wiring. When using ITO material for wire, though efforts can be made in design to ensure consistency in channel wiring through length and width matching, yet difference still exists to some extent. To ensure data consistency and uniformity for the entire screen, it is required to ensure wiring impedance complies with the above requirements.
3. When driver wiring and sensor wiring are adjacent and parallel to each other, grounding should be provided in between, and grounding width should be at least twice the width of channel wiring or no less than 0.2mm. To provide better touch effect, it is recommended to provide wiring on both sides.

5.4. Touch-screen Homekey design

GT9113 supports Win8 standard Homekey and Homekey functions consist of 4-5 touch keys which are accomplished as shown below:

Sensor extension mode: Drive channel serves as common port for touch keys where one drive channel are connected with 4-5 sensing channels to form 4-5 keys. Drive channels used as keys cannot be used in duplex on screen but sensing channels used as keys must be used in duplex on screen;

See Goodix “Win8_Homekey Graphic Design Specification” for specific rules for Homekey design.

6. I2C&USB communication

6.1. I²C communication

GT9113 provides standard I²C HID communication interface for SCL and SDA to communicate with CPU. GT9113 invariably serves as slave unit and all communication is initiated by master CPU. It is recommended to adopt 400Kbps or lower communication speed. Its supported I²C hardware circuit supports the following sequence:

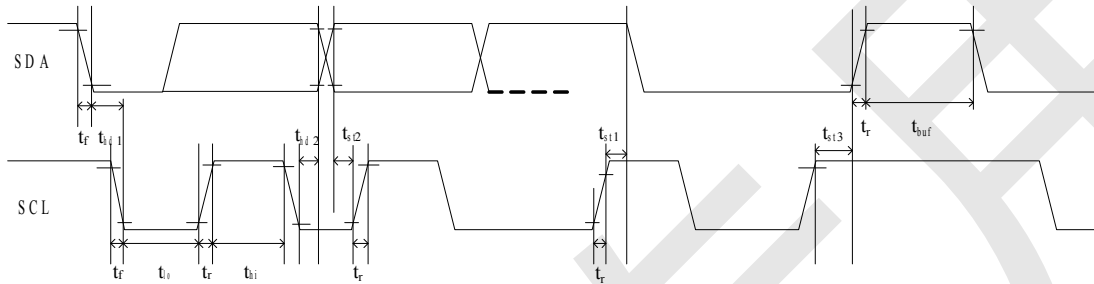

Test condition 1: 1.8V communication interface, 400Kbps communication speed, pull-up resistor 2K

Parameter	Symbol	Min.	Max.	Unit
SCL low period	t_{lo}	1.3	-	us
SCL high period	t_{hi}	0.6	-	us
SCL setup time for START condition	t_{st1}	0.6	-	us
SCL setup time for STOP condition	t_{st3}	0.6	-	us
SCL hold time for START condition	t_{hd1}	0.6	-	us
SDA setup time	t_{st2}	0.1	-	us
SDA hold time	t_{hd2}	0	-	us

Test condition 2: 3.3V communication interface, 400Kbps communication speed, pull-up resistor 2K

Parameter	Symbol	Min.	Max.	Unit
SCL low period	t_{lo}	1.3	-	us
SCL high period	t_{hi}	0.6	-	us
SCL setup time for START condition	t_{st1}	0.6	-	us
SCL setup time for STOP condition	t_{st3}	0.6	-	us
SCL hold time for START condition	t_{hd1}	0.6	-	us
SDA setup time	t_{st2}	0.1	-	us
SDA hold time	t_{hd2}	0	-	us

GT9157 I²C slave unit address includes two groups: 0xBA/0xBB and 0x28/0x29.

a) Data transmission

(0xBA/0xBB as device address)

Communication is always initiated by master CPU and effective start signal is: When SCL remains “1”, hopping from “1” to “0” occurs on SDA. Address information or data flow is transmitted after start signal.

All slave devices connected on I²C bus have to test 8-bit address information sent on test bus after start signal and launch correct response. When receiving compatible address information, GT9113 changes SDA as output port at the 9th clock cycle and resets to “0” as ACK signal. If address information received is incompatible, i.e., it is neither 0xBA nor 0xBB, GT9113 will maintain idle status.

Data on SDA port sends 9-bit data in series based on 9 clock cycles: 8-bit effective data and 1-bit ACK signal or NACK signal sent back by recipient. Data transmission is effective when SCL is “1”.

When communication is complete, master CPU will send stop signal. Stop signal means when SCL is “1”, SDA status hops from “0” to “1”.

b) Capture report descriptor

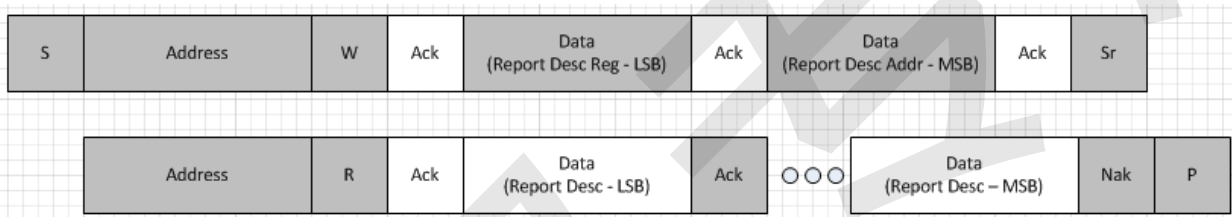

Operating sequence for capturing report descriptor

The diagram above shows the operating procedures for master device to capture report descriptor. First, master device generates a start signal; then, it sends device address information and read/write bit information.

After receiving ACK, master device sends 16-bit report descriptor address.

After slave device responds, master device begins to capture data from slave device; master device replies with an ACK to slave device for every BYTE and replies with NACK for the last BYTE. Finally, it sends end mark.

c) Capture HID descriptor

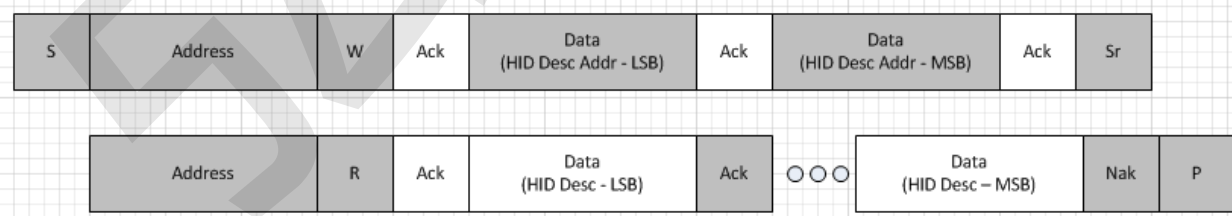

The operating procedures for capturing HID descriptor are similar to those for capturing report descriptor. After sending device address information and read-write bit information, master device receives ACK from slave device and sends a 16-bit HID descriptor address. After slave device replies with ACK, master device begins to capture data; master device replies with an ACK to slave device for every BYTE and replies with NACK for the last BYTE. Finally, it sends end mark.

d) R/W operating procedures and feature message

When slave device needs to capture data from master device, it first pulls INT trigger interruption. After master device receives interruption, it sends device address information and read/write bit; after slave device replies with ACK, master device begins to capture data; master device replies with an ACK to slave device for every BYTE and replies with NACK for the last BYTE. Finally, it sends end mark. Now, slave device releases INT pin.

When sending data, master device first sends device address information and read/write bit. After slave device replies with ACK, master device begins to send data; master device waits for slave device to reply with an ACK for every BYTE. After master device sends the last BYTE and receives ACK from slave device, master device sends end mark to complete the sending process.

Feature message is a two-way message sent between master device and slave. For example, it is used for master device to change the status of slave device, such as Reset.

6.2. USB communication

When the format for USB to report data is ID + coordinate data, ID is 1; When the format for USB to report data is ID + coordinate point, ID is 2.

GT9113 USB is transmitted to MCU in data packet format compliant with WIN8 protocol. GT9113 supports a maximum of 10 fingers. When the number of touch fingers is less than or equal to 6, only one data packet (first 64 bytes) is transmitted at a time; When the number of touch fingers is greater than 6, two data packets (128 bytes) are transmitted. Specific format for data packet is as shown below:

0	ReportID
1	valid_point_flag
2	track id
3	point 1 x coordinate (low byte)
4	point 1 x coordinate (high byte)
5	point 1 y coordinate (low byte)
6	point 1 y coordinate (high byte)
7	point 1 rect_x_size(low byte)
8	point 1 rect_x_size(high byte)
9	point 1 rect_y_size(low byte)
10	point 1 rect_y_size(high byte)
11	valid_point_flag

12	track id
13	point 2 x coordinate (low byte)
14	point 2 x coordinate (high byte)
15	point 2 y coordinate (low byte)
16	point 2 y coordinate (high byte)
17	point 2 rect_x_size(low byte)
18	point 2 rect_x_size(high byte)
19	point 2 rect_y_size(low byte)
20	point 2 rect_y_size(high byte)
21	valid_point_flag
22	track id
23	point 3 x coordinate (low byte)
24	point 3 x coordinate (high byte)
25	point 3 y coordinate (low byte)
26	point 3 y coordinate (high byte)
27	point 3 rect_x_size(low byte)
28	point 3 rect_x_size(high byte)
29	point 3 rect_y_size(low byte)
30	point 3 rect_y_size(high byte)
31	valid_point_flag
32	track id
33	point 4 x coordinate (low byte)
34	point 4 x coordinate (high byte)
35	point 4 y coordinate (low byte)
36	point 4 y coordinate (high byte)
37	point 4 rect_x_size(low byte)
38	point 4 rect_x_size(high byte)
39	point 4 rect_y_size(low byte)
40	point 4 rect_y_size(high byte)
41	valid_point_flag
42	track id
43	point 5 x coordinate (low byte)
44	point 5 x coordinate (high byte)
45	point 5 y coordinate (low byte)
46	point 5 y coordinate (high byte)
47	point 5 rect_x_size(low byte)
48	point 5 rect_x_size(high byte)

49	point 5 rect_y_size(low byte)
50	point 5 rect_y_size(high byte)
51	valid_point_flag
52	track id
53	point 6 x coordinate (low byte)
54	point 6 x coordinate (high byte)
55	point 6 y coordinate (low byte)
56	point 6 y coordinate (high byte)
57	point 6 rect_x_size(low byte)
58	point 6 rect_x_size(high byte)
59	point 6 rect_y_size(low byte)
60	point 6 rect_y_size(high byte)
61	ScanTime(low byte)
62	ScanTime(high byte)
63	TouchCount
64	ReportID
65	valid_point_flag
66	track id
67	point 7 x coordinate (low byte)
68	point 7 x coordinate (high byte)
69	point 7 y coordinate (low byte)
70	point 7 y coordinate (high byte)
71	point 7 rect_x_size(low byte)
72	Point 7 rect_x_size(high byte)
73	point 7 rect_y_size(low byte)
74	point 7 rect_y_size(high byte)
75	valid_point_flag
76	track id
77	point 8 x coordinate (low byte)
78	point 8 x coordinate (high byte)
79	point 8 y coordinate (low byte)
80	point 8 y coordinate (high byte)
81	point 8 rect_x_size(low byte)
82	point 8 rect_x_size(high byte)
83	point 8 rect_y_size(low byte)
84	point 8 rect_y_size(high byte)
85	valid_point_flag

86	track id
87	point 9 x coordinate (low byte)
88	point 9 x coordinate (high byte)
89	point 9 y coordinate (low byte)
90	point 9 y coordinate (high byte)
91	point 9 rect_x_size(low byte)
92	point 9 rect_x_size(high byte)
93	point 9 rect_y_size(low byte)
94	point 9 rect_y_size(high byte)
95	valid_point_flag
96	track id
97	point 10 x coordinate (low byte)
98	point 10 x coordinate (high byte)
99	point 10 y coordinate (low byte)
100	point 10 y coordinate (high byte)
101	point 10 rect_x_size(low byte)
102	point 10 rect_x_size(high byte)
103	point 10 rect_y_size(low byte)
104	point 10 rect_y_size(high byte)
105	0x00
106	0x00
107	0x00
108	0x00
109	0x00
110	0x00
111	0x00
112	0x00
113	0x00
114	0x00
115	0x00
116	0x00
117	0x00
118	0x00
119	0x00
120	0x00
121	0x00
122	0x00

123	0x00
124	0x00
125	ScanTime(low byte)
126	ScanTime(high byte)
127	0x00

Some description:

1. ReportID: ID for report descriptor, 0x01 here;
2. valid_point_flag: Whether the point is valid, valid when it is 0x01 and 0x00 means key is released;
3. ScanTime: Time stamp, unit is 100us.

6.3. GT9113 register information

a) Real-time command

(Write Only)

Addr	name	bit7	bit6	bit5	bit4	bit3	bit2	bit1	bit0
0x8040	Command	0: Read coordinate status 1: Original deviation value 2: Software resetting 3: Benchmark update (Internal test) 4: Benchmark calibration (Internal test) 5:Screen off Other value invalid							

b) Configuration information

(R/W)

Register	Config Data	bit7	bit6	bit5	bit4	bit3	bit2	bit1	bit0
0x8047	Config_Version	The version number of configuration documents (To be saved when the version number of new release is greater than the original version or equal to the version number of the original version but there is some change in contents; Normal range of version number: 'A'~'Z'; Send 0x00 to initiate version number as 'A')							
0x8048	X Output Max (Low Byte)	Max value from X coordinate output							
0x8049	X Output Max (High Byte)								
0x804A	Y Output Max (Low Byte)	Max value from Y coordinate output							
0x804B	Y Output Max (High Byte)								
0x804C	Touch Number	Reserved				Maximum output touch points: 1~10			
0x804D	Module_Switch1	Reserved		Stretch_rank		X2Y (X, Y coordinate interchange)	Sito ((Software noise reduction))	Reserved	

0x804E	Module_switch2	Reserved	Reserved	New_Green_Mode_EN	Reserved	Reserved	Reserved	Reserved	Touch_key
0x804F	Shake_Count	Reserved				Debouncing count when finger presses down/releases			
0x8050	Filter	First_Filter	Normal_Filter(Coefficient of filter value for original coordinate window: 1)						
0x8051	Large_Touch	Large-area touch point count							
0x8052	Noise_Reduction	Reserved				Noise elimination value (Valid when coefficient is 1,0-15)			
0x8053	Screen_Touch_Level	Threshold of touch points on screen from none to availability							
0x8054	Screen_Leave_Level	Threshold of touch points on screen from availability to none							
0x8055	Low_Power_Control	Reserved				Enter low consumption time (0~15s)			
0x8056	Refresh_Rate	Reserved				Coordinate reporting rate (Cycle: 5+N ms)			
0x8057	x_threshold	Reserved							
0x8058	y_threshold								
0x8059	X_Speed_Limit	Reserved							
0x805A	Y_Speed_Limit								
0x805B	Space	Space at upper frame (32 as coefficient)				Space at lower frame (32 as coefficient)			
0x805C		Space at left frame (32 as coefficient)				Space at right frame (32 as coefficient)			
0x805D	Mini_Filter	Reserved				Minimum filter setting in the drawing process			
0x805E	Stretch_R0	Space 1 coefficient							
0x805F	Stretch_R1	Space 2 coefficient							
0x8060	Stretch_R2	Space 3 coefficient							
0x8061	Stretch_RM	Base number for various spaces							
0x8062	Drv_GroupA_Num	All_Driving	Reserved			Driver_Group_A_number			
0x8063	Drv_GroupB_Num	Reserved			Dual_Freq	Driver_Group_B_number			
0x8064	Sensor_Num	Sensor_Group_B_Number				Sensor_Group_A_Number			
0x8065	FreqA_factor	Double frequency coefficient for drive frequency of drive group A $\text{GroupA_Frequency} = \text{Double frequency coefficient} * \text{Base frequency}$							
0x8066	FreqB_factor	Double frequency coefficient for drive frequency of drive group B $\text{GroupB_Frequency} = \text{Double frequency coefficient} * \text{Base frequency}$							
0x8067	Pannel_BitFreqL	Base frequency of drive groups A and B (1526HZ<Base frequency<14600Hz)							
0x8068	Pannel_BitFreqH								
0x8069	Pannel_Sensor_Ti meL	Time interval between two adjacent drive signal outputs (Unit: us), Reserved (beta version occupied. Released version invalid)							
0x806A	Pannel_Sensor_Ti meH								

0x806B	Pannel_Tx_Gain	Reserved			Pannel_Drv_output_R 4 positions, adjustable	Pannel_DAC_Gain 0:Gain max 7: Gain min
0x806C	Pannel_Rx_Gain	Pannel_PGA_C	Pannel_PGA_R		Pannel_Rx_Vcmi (4 positions, adjustable)	Pannel_PGA_Gain (8 positions, adjustable)
0x806D	Pannel_Dump_Shift	Reserved			Amplification coefficient for screen original value (2 ^N)	
0x806E	Drv_Frame_Control	Reserved	SubFrame_DrvNum			Repeat_Num (Accumulated sampling count)
0x806F	NC	Reserved				
0x8070	NC	Reserved				
0x8071	NC	Reserved				
0x8072	NC	Reserved				
0x8073	NC	Reserved				
0x8074	NC	Reserved				
0x8075	NC	Reserved				
0x8076	NC	Reserved				
0x8077	NC	Reserved				
0x8078	NC	Reserved				
0x8079	NC	Reserved				
0x807A	Freq_Hopping_Start	Start frequency for the range of hopping frequency (2KHz unit, such as 50 for 100KHz)				
0x807B	Freq_Hopping_End	End frequency for the range of hopping frequency (2KHz unit, such as 150 for 300KHz)				
0x807C	Noise_Detect_Times	Detect_Stay_Times (Number of tests per frequency point in each noise test, 2 recommended)		Detect_Confirm_Times (Determine noise level after repeated noise test, 1-63 valid, 20 recommended)		
0x807D	Hopping_Flag	Hopping_En	Range_Ext	Dis_Force_Ref	Reserved	Detect_Time_Out (Timeout time for noise test, in second)
0x807E	Hopping_Threshold	Fast_Hopping_Limit judgment is enabled only when the interference value of current frequency is greater than Fast_Hopping_Limit*4, this value is set as 5 minimum			Hopping_Hit_Threshold (Conditions for selecting optimal frequency, Current working frequency interference-Minimum interference > Set value x4, then optimal frequency and hopping is selected)	
0x807F	Noise_Threshold	Judge threshold with interference (Deemed as free from interference if interference is below this value at all frequency points)				
0x8080	NC	Reserved				
0x8081	NC	Reserved				

0x8082	Hopping_Sensor_Group	Sections for Hopping Frequency Noise Detection (4 sections recommended).
0x8083	Hopping_seg1_Normalize	Seg1 Normalize coefficient (Times this value, then divided by 128 to get eventual Rawdata).
0x8084	Hopping_seg1_Factor	Seg1 Central Factor.
0x8085	Main_Clock_Adjust	Fine adjustment of basic frequency configuration, range-7~+8; normally, no configuration is necessary, 0 for default value.
0x8086	Hopping_seg2_Normalize	Seg2 Normalize coefficient (Times this value, then divided by 128 to get eventual Rawdata).
0x8087	Hopping_seg2_Factor	Seg2 Central Factor
0x8088	Reserved	Reserved
0x8089	Hopping_seg3_Normalize	Seg3 Normalize coefficient (Times this value, then divided by 128 to get eventual Rawdata).
0x808A	Hopping_seg3_Factor	Seg3 Central Factor
0x808B	Reserved	Reserved
0x808C	Hopping_seg4_Normalize	Seg4 Normalize coefficient (Times this value, then divided by 128 to get eventual Rawdata).
0x808D	Hopping_seg4_Factor	Seg4 Central Factor
0x808E	Reserved	Reserved
0x808F	Hopping_seg5_Normalize	Seg5 Normalize coefficient (Times this value, then divided by 128 to get eventual Rawdata).
0x8090	Hopping_seg5_Factor	Seg5 Central Factor.
0x8091	Reserved	Reserved
0x8092	Hopping_seg6_Normalize	Seg6 Normalize coefficient (Times this value, then divided by 128 to get eventual Rawdata).
0x8093	NC	Reserved
0x8094	NC	Reserved
0x8095	NC	Reserved
0x8096	NC	Reserved
0x8097	NC	Reserved
0x8098	NC	Reserved
0x8099	NC	Reserved
0x809A	NC	Reserved
0x809B	NC	Reserved
0x809C	NC	Reserved
0x809D	New_Green_Mode_Wake_Up_Level	New_Green low consumption mode wake threshold.
0x809E	New_Green_Dump_Shift	500uA dump_shift
0x809F	CS_PGA_R	Pannel_PGA_R in CS mode
0x80A0	CS_PGA_GAIN	Pannel_PGA_Gain in CS mode (8 position adjustable)
0x80A1	CS_DUMP_SHI	Amplification coefficient for initial screen value (2 ^N)

FT		
0x80A2	CS_NOISE_THRESHOLD	CS noise threshold in CS mode
0x80A3	CS_SEG1_NORMALIZE	Seg1 Normalize coefficient in CS mode
0x80A4	CS_SEG2_NORMALIZE	Seg2 Normalize coefficient in CS mode
0x80A5	CS_SEG3_NORMALIZE	Seg3 Normalize coefficient in CS mode
0x80A6	CS_SEG4_NORMALIZE	Seg4 Normalize coefficient in CS mode
0x80A7	CS_SEG5_NORMALIZE	Seg5 Normalize coefficient in CS mode
0x80A8	NC	Reserved
0x80A9	NC	Reserved
0x80AA	NC	Reserved
0x80AB	NC	Reserved
0x80AC	NC	Reserved
0x80AD	NC	Reserved
0x80AE	NC	Reserved
0x80AF	NC	Reserved
0x80B0	NC	Reserved
0x80B1	NC	Reserved
0x80B2	NC	Reserved
0x80B3	X_Physical(Low Byte)	The physical resolution in X direction.
0x80B4	X_Physical(High Byte)	
0x80B5	Y_Physical(Low Byte)	The physical resolution in Y direction.
0x80B6	Y_Physical(High Byte)	
0x80B7 ~ 0x80D4	Sensor_CH0~ Sensor_CH29	Chip channel number corresponding to ITO Sensor
0x80D5~ 0x80FE	Driver_CH0~ Driver_CH41	Chip channel number corresponding to ITO Driver
0x80FF	Config_Chksum	Configuration information verification (Complementary code for total bytes from 0x8047 to 0x80FE)
0x8100	Config_Fresh	Configure updated tag (tag to be written by MCU)

Supplementary description for some registers:

[0x809D] X_Physical_Max_L: Low byte of actual physical length for the screen in X direction, in mm

[0x809E] X_Physical_Max_H: High byte of actual physical length for the screen in X direction, in mm

[0x809F] Y_Physical_Max_L: Low byte of actual physical length for the screen in Y direction, in mm

[0x80A0] Y_Physical_Max_H: High byte of actual physical length for the screen in Y direction, in mm

7. Function description

7.1. I²C working mode

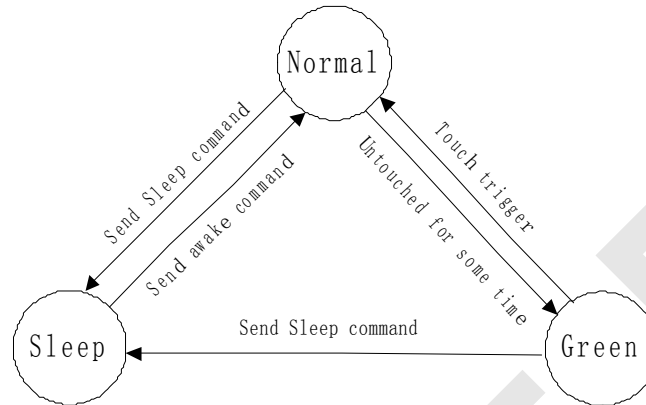

a) Normal Mode

When GT9113 is in Normal mode, its coordinates refreshing cycle is lower than or equal to 10ms.

When no trigger event occurs for some time in Normal mode, GT9113 will automatically switch to Green mode to reduce power consumption. The duration when GT9113 remains untouched before automatically entering Green mode can be set through information configuration within the range of 0~15s, 1s for increment.

b) Green Mode

In Green mode, the scanning cycle for GT9113 is around 20ms. It automatically enters Normal mode when detecting any trigger operation.

c) Sleep Mode

When Sleep command is sent via I2C for HOST, GT9113 will enter Sleep mode. When HOST sends Wake command via I2C, GT9113 will enter Normal mode after waking up.

7.2. USB working mode

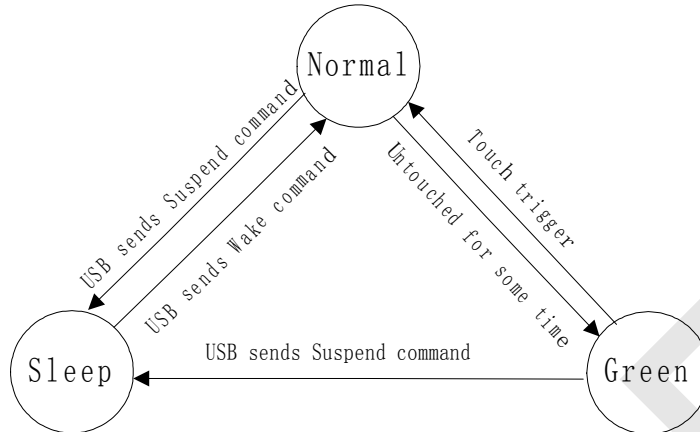

a) Normal Mode

When GT9113 is in Normal mode, its fastest coordinates refreshing cycle is 10ms.

When no trigger event occurs for some time in Normal mode, GT9113 will automatically switch to Green mode to reduce power consumption. The duration when GT9113 remains untouched before automatically entering Green mode can be set through information configuration within the range of 0~15s, 1s for increment. When set as “0”, the system will not enter Green mode.

b) Green Mode

In Green mode, the scanning cycle for GT9113 is around 20ms. It automatically enters Normal mode when detecting any triggering operation.

c) Sleep Mode

When Sleep command is sent via USB for MCU, GT9113 will enter Sleep mode. When MCU sends Wake command via USB, GT9113 will enter Normal mode after waking up.

7.3. Interrupted trigger mode

When touched in I2C HID mode, GT9113 will give out pulse signal when passing INT pin in every scanning cycle to notify master CPU to read coordinates information. INT initial state to a high state, when INT is low, the host began to read coordinates, coordinates read after completion, INT recovery is high.

7.4. Solidifying configuration function

GT9113 supports Solidifying configuration function. After capturing configuration parameter for any item, GT9113 will solidify the configuration parameter with higher version number. After solidifying configuration parameter, GT9113 will not receive any configuration of lower version number from master CPU.

7.5. Automatic calibration

a) Initial calibration

Difference in temperature, humidity and physical space structure may affect the benchmark value of capacitive sensor in idle status. Within the initial 200ms, GT9113 will capture new test benchmark depending on environmental conditions to complete initialization for touch screen test.

b) Automatic thermal drift compensation

Slow change in environmental factors such as temperature, humidity or dust may also affect the benchmark value of capacitive sensor in idle status. GT9113 will check for any change in any data on real-time basis, and perform statistic analysis of historic data to correct test benchmark and thus reduce the impact of environmental change on touch screen test.

8. Reference circuit diagram

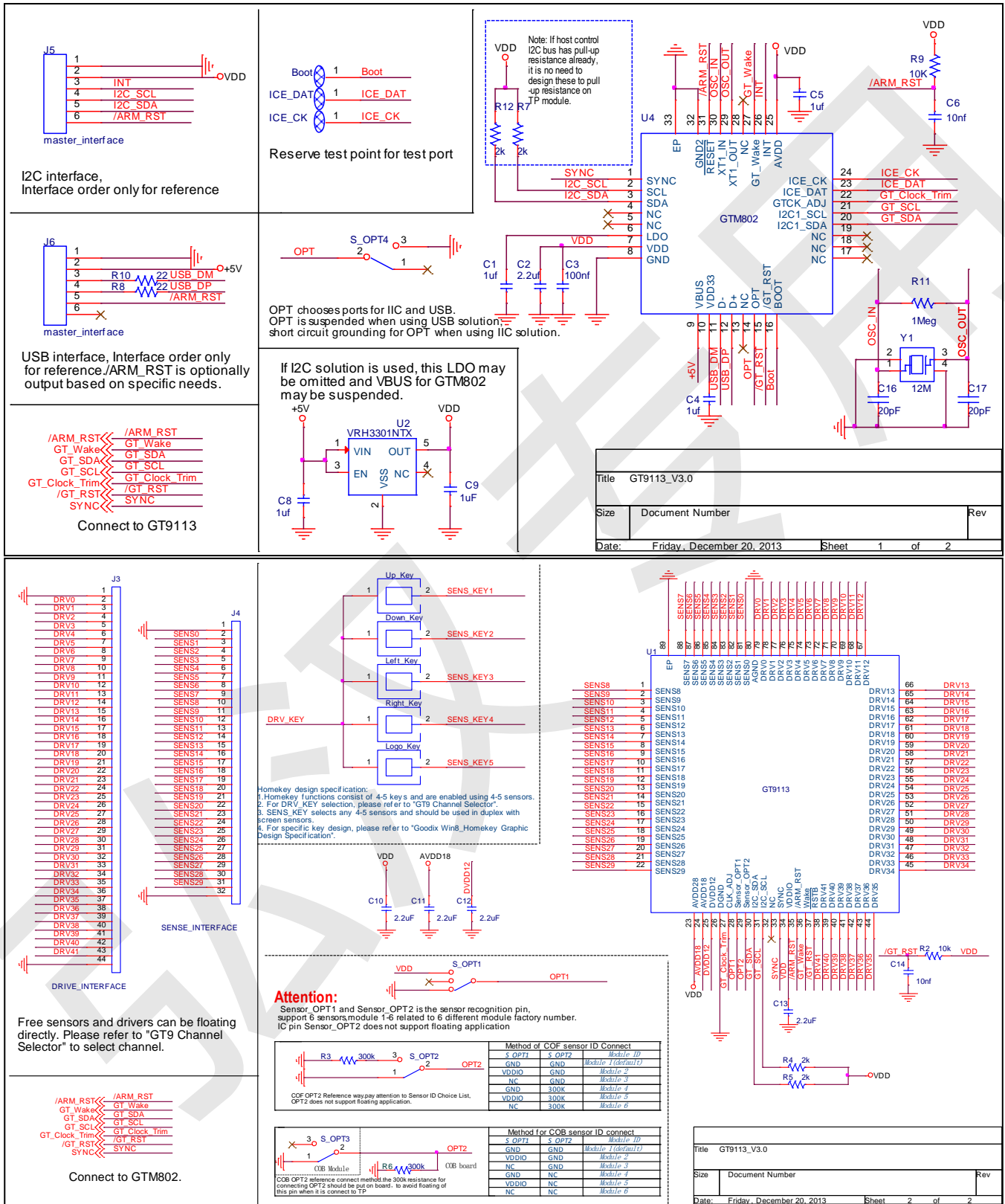

GT9113 reference circuit diagram

GT9113 reference circuit diagram

Notes:

1. This circuit only represents basic application. Adjustment may be required for some circuits depending on application environments.
2. X7R material is recommended for capacitor.

9. Electrical characteristics

9.1. Extreme electrical parameter

(GT9113, 25°C for environmental temperature)

Parameter	Min. value	Max. value	Unit
Analog power AVDD28 (Refer to AGND)	2.66	3.47	V
VDDIO (Refer to DGND)	1.7	3.47	V
Voltage acceptable to digital I/O	-0.3	3.47	V
Voltage acceptable to analog I/O	-0.3	3.47	V
Range of operating temperature	-40	85	°C
Range of storage temperature	-60	125	°C
Welding temperature (10s)		300	°C
ESD protection voltage (HB Model)	-	±2	KV

(GTM802, 25°C for environmental temperature)

Parameter	Min. value	Max. value	Unit
Power AVDD (Refer to GND)	-0.3	7.0	V
Voltage acceptable to digital I/O	GND-0.3	VDD+0.3	V
Voltage acceptable to analog I/O	GND-0.3	VDD+0.3	V
Range of operating temperature	-40	85	°C
Range of storage temperature	-55	125	°C
Welding temperature (10s)		300	°C
ESD protection voltage (HB Model)	—	±2	KV

9.2. Recommended working conditions

(GT9113)

Parameter	Min. value	Typical value	Max. value	Unit
AVDD28	2.8	-	3.3	V
VDDIO	1.8	-	3.3	V
Operating temperature	-20	25	85	°C

(GTM802)

Parameter	Min. value	Typical value	Max. value	Unit
VDD	2.5	-	5.5	V
Operating temperature	-20	25	85	°C

9.3. AC characteristics

(GT9113, 25°C for environmental temperature, AVDD=2.8V, VDDIO=1.8V)

Parameter	Min. value	Typical value	Max. value	Unit
OSC oscillation frequency	59	60	61	MHz

Time for I/O output to switch from low to high	-	-	0.5	ns
Time for I/O output to switch from high to low	-	-	0.5	ns

(Electrical characteristics for GTM802 full speed USB drive)

Parameter	Min. value	Typical value	Max. value	Unit
Ascend time (C _L =50p)	4	-	20	MHz
Descend time (C _L =50p)	4	-	20	ns
Ascend/Descend ratio (Ascend time/Descend time)	90	-	111.1	%

9.4. DC characteristics

(GT9113, 25°C for environmental temperature, AVDD=2.8V, VDDIO=1.8V)

Parameter	Min. value	Typical value	Max. value	Unit
Normal mode working current	-	13	-	mA
Green mode working current	-	4.5	-	mA
Sleep mode working current	70	-	120	Ua
Low level voltage value for digital input	-0.3	0	0.45	V
High level voltage value for digital input	1.35	1.8	2.1	V

(GTM802, 25°C for environmental temperature, VDD=3.3V, External clock=12MHz)

Parameter	Min. value	Typical value	Max. value	Unit
Normal mode working current	3.5	-	5.5	mA
Idea mode working current	2.5	-	4.5	mA
Deep Sleep mode working current	9	-	10.5	uA
Low level voltage value for digital input	-0.3	-	0.8	V
High level voltage value for digital input (VDD=3.0V)	1.5	-	VDD+0.2	V

10. Product packaging

10.1. GT9113 packaging

TOP VIEW

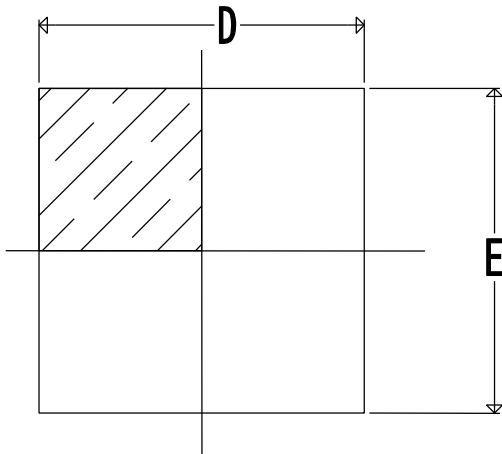

BOTTOM VIEW

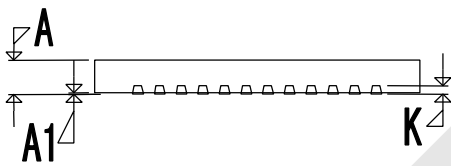
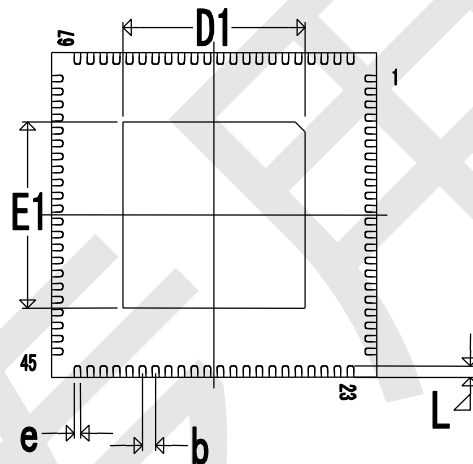

SIDE VIEW

QFN 10 X 10 88PIN
0.4 PITCH SQUARE

Symbol	Dimensions in millimeters		
	Min.	Normal	Max.
A	0.70	0.75	0.80
A1	0.00	0.035	0.05
b	0.40BSC		
D	10.00BSC		
D1	5.50	5.60	5.90
E	10.00BSC		
E1	5.20	5.60	5.80
e	0.15	0.20	0.25
L	0.30	0.40	0.50
K	0.203BSC		

10.2. GTM802 Packaging

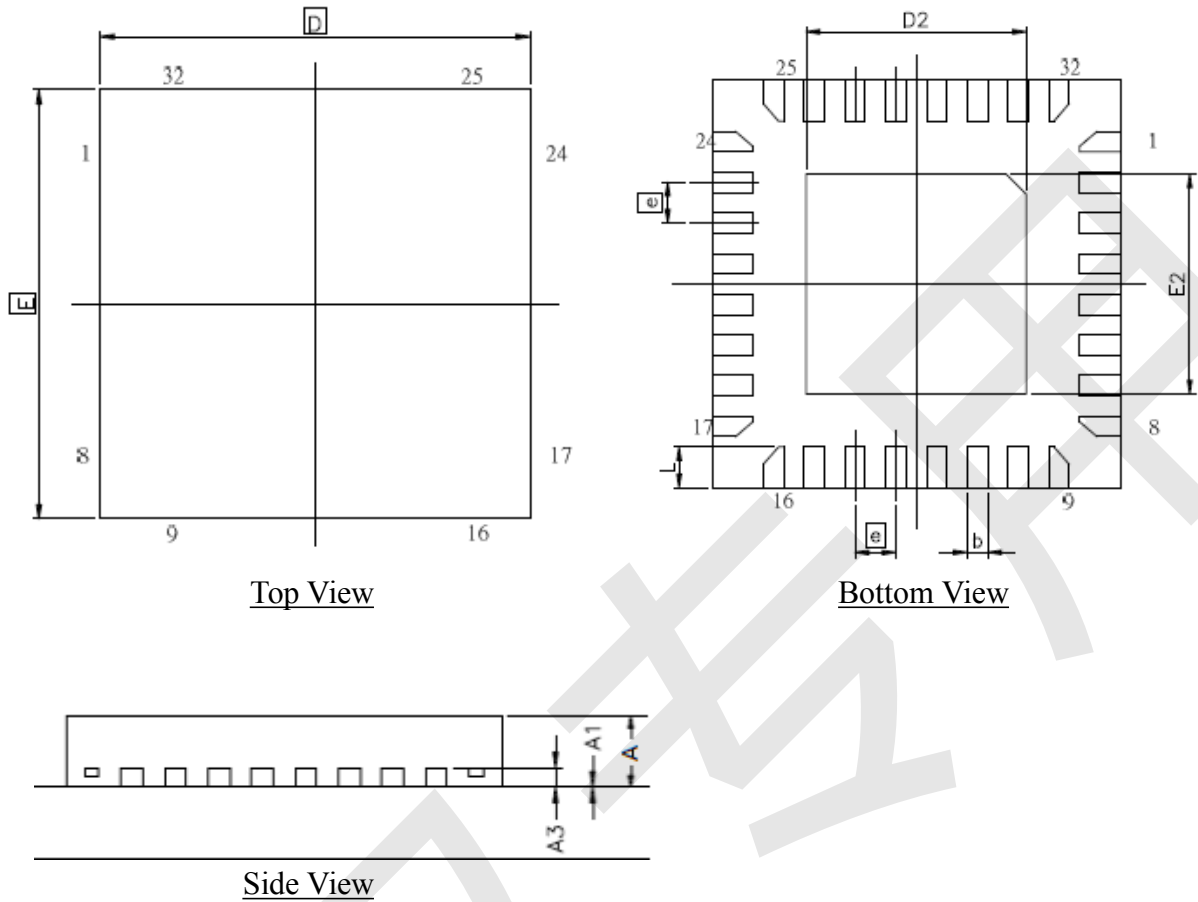

Unit: mm			
Symbol	Min	Typ. Value	Max.
A	0.70	0.75	0.80
A1	0	0.02	0.05
A3	0.20REF		
b	0.18	0.25	0.30
D	5.00BSC		
D2	2.60	2.70	2.80
E	5.00BSC		
E2	2.60	2.70	2.80
e	0.50BSC		
L	0.30	0.40	0.50
Y	0.10		

11. Revision Record

Version No	Date revised	Revision
Rev.00	2013-03-29	Initial release
Rev.01	2013-05-07	Modified schematic diagram
Rev.02	2013-05-14	Added “Conditions for tin furnace” section
Rev.03	2013-11-05	Modify the configuration information
Rev.04	2013-12-30	Added I2C HID and Homekey

12. Contact Information



Shenzhen Huiding Technology Co.,Ltd.

Floor 13, Phase B, Tengfei Industrial Building, Futian Free Trade Zone Shenzhen, 518000

TEL: +86-755-33338828 FAX: +86-755-33338828

www.goodix.com

Our company network supports you worldwide with offices in Germany, Great Britain, Italy, Turkey and the USA. For more information please contact:



DATA DISPLAY GROUP

Distec GmbH

Augsburger Str. 2b
82110 Germering
Germany

Phone: +49 (0)89 / 89 43 63-0
Fax: +49 (0)89 / 89 43 63-131
E-Mail: info@datadisplay-group.de
Internet: www.datadisplay-group.de

Display Technology Ltd.

5 The Oaks Business Village
Revenge Road, Lordswood
Chatham, Kent, ME5 8LF
United Kingdom

Phone: +44 (0)1634 / 67 27 55
Fax: +44 (0)1634 / 67 27 54
E-Mail: info@datadisplay-group.co.uk
Internet: www.datadisplay-group.co.uk

Apollo Display Technologies, Corp.

87 Raynor Avenue, Unit 1 Ronkonkoma, NY
11779

United States of America

Phone: +1 631 / 580-43 60
Fax: +1 631 / 580-43 70
E-Mail: info@datadisplay-group.com
Internet: www.datadisplay-group.com

Sales Partner:

REM Italy s.a.s.

di Michieletto Flavio & C.
Via Obbia Bassa, 10
I-35010 Trebaseleghe (PD)
Italy
Phone: +39 335 521 37 89
E-Mail: info@remitaly.com
Internet: www.remitaly.com

Sales Partner:

DATA DISPLAY BİLİŞİM TEKNOLOJİLERİ İÇ VE DIŞ TİCARET LİMİTED ŞİRKETİ

Barbaros Mh Ak Zamabak Sk A Blok
D:143 Ataşehir/İstanbul
Turkey
Phone: +90 (0)216 / 688 04 68
Fax: +90 (0)216 / 688 04 69
E-Mail: info@data-display.com.tr
Internet: www.data-display.com.tr