

UNIVERSAL TURRET MILLGUARD - FITTING INSTRUCTIONS

1. Loosen nuts 'A' allowing 'V' blocks to slide.
2. Tighten 'T' bar "B" to clamp 'V' blocks onto 'V' slide. Adjust to give best position for guarding cutter. (Left or Right) (Up or Down)
3. Tighten nuts 'A'.
4. Slide guard (in/out) to position around cutter and secure pinch screws "C".

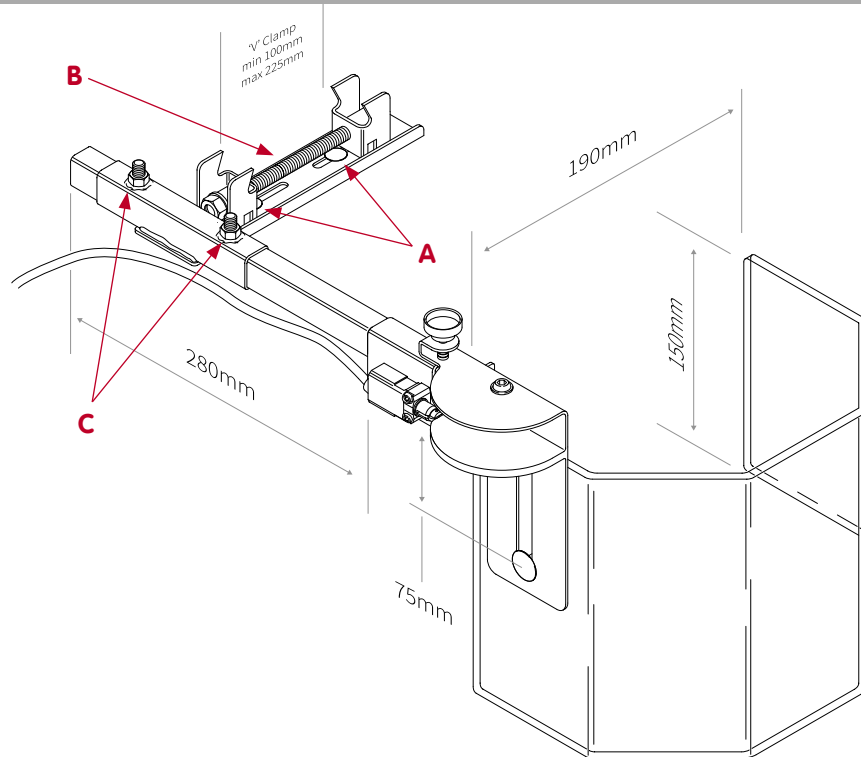

SILVAFLAME-CLEERVUE COMPANY LIMITED

22, Park Street, Bridgtown, Cannock,
Staffordshire, WS11 0BX. United Kingdom.

T: 01543 431060

F: 01543 509140

e-mail: silvaflame@cleervue.com
www.silvaflame.com

UNIVERSAL TURRET MILLGUARD - FITTING INSTRUCTIONS

1. Loosen nuts 'A' allowing 'V' blocks to slide.
2. Tighten 'T' bar "B" to clamp 'V' blocks onto 'V' slide. Adjust to give best position for guarding cutter. (Left or Right) (Up or Down)
3. Tighten nuts 'A'.
4. Slide guard (in/out) to position around cutter and secure pinch screws "C".

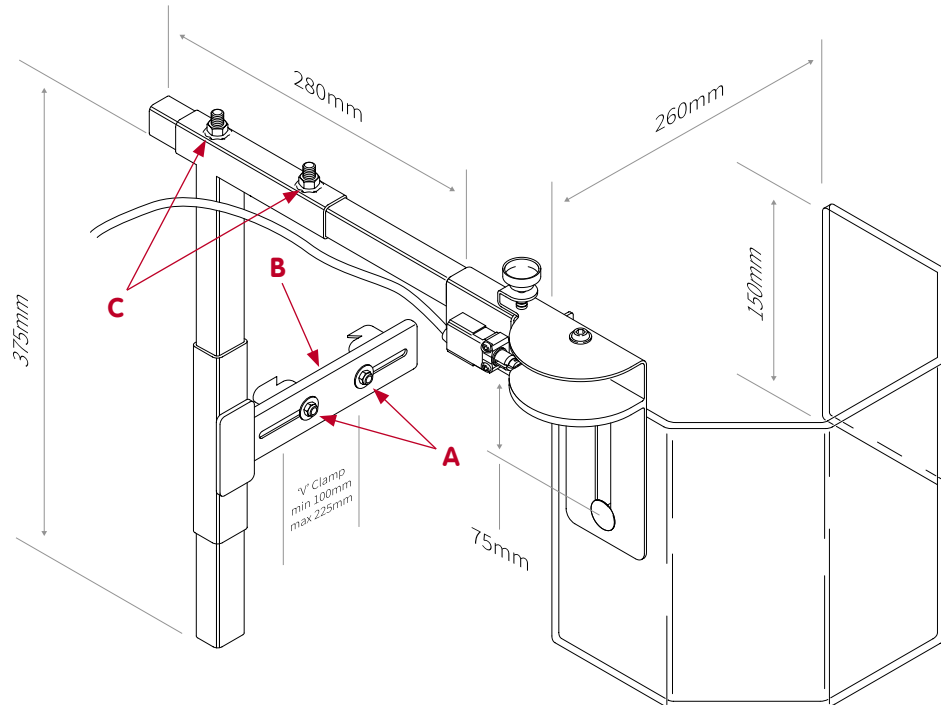

SILVAFLAME-CLEERVUE COMPANY LIMITED

22, Park Street, Bridgtown, Cannock,
Staffordshire, WS11 0BX. United Kingdom.

T: 01543 431060

F: 01543 509140

e-mail: silvaflame@cleervue.com
www.silvaflame.com