

# RWM 500 Baling Press

Take control and convert your dry recyclable packing waste into manageable bales. Recyclers and industrial users of a Riverside vertical baler benefit from waste volume reduction; storage, handling and transportation savings; avoidance of ever-increasing landfill charges; the satisfaction of environmental benefits and even possibly the generation of an additional revenue yield.

## RWM 500 Baling Press

- ✓ 12 month warranty
- ✓ 1500mm wide feed aperture
- ✓ Can be sited outside
- ✓ Available in 16 amp 3-phase or 16 amp single phase electrics
- ✓ 50 Tonne press force
- ✓ 5 wire tying for a secure bale
- ✓ Automatic bale ejection
- ✓ Bale weights up to 550kg
- ✓ CE approved
- ✓ Fitted retaining claws to prevent material spring back
- ✓ Powder coated finish for durability



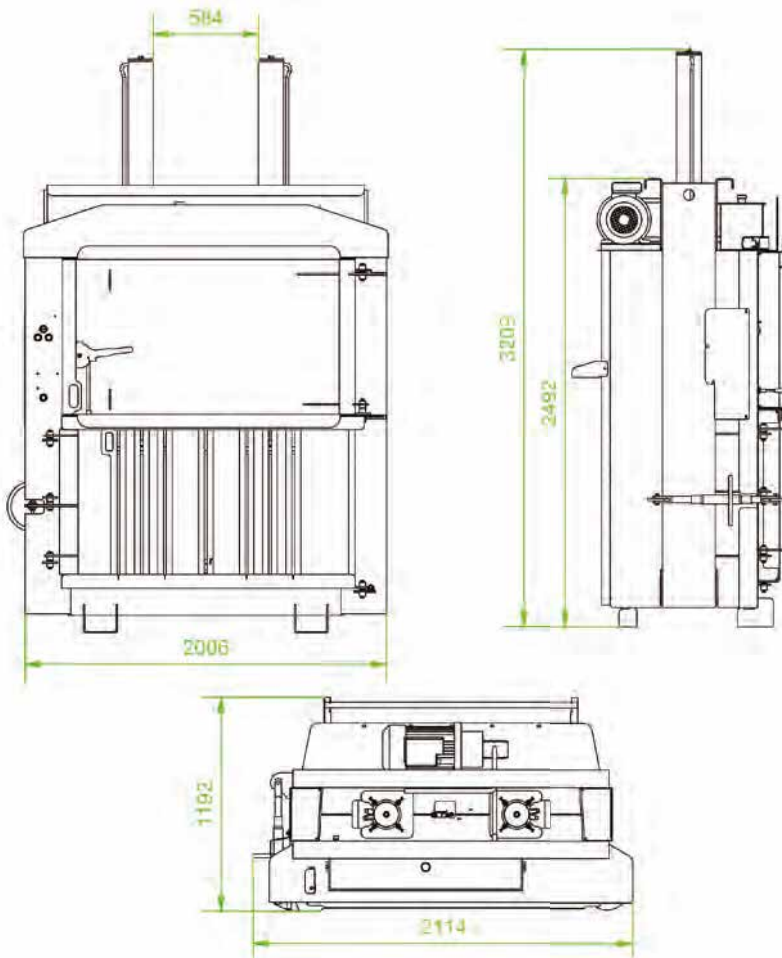

<b>Press Force</b>	50 Tonnes
<b>Loading Aperture (H x W x D)</b>	880 x 1500 x 769mm
<b>Bale Weight</b>	up to 550 Kg
<b>Bale Dimensions (H x W x D)</b>	1200 x 1500 x 769mm
<b>Cycle Time</b>	40 seconds
<b>Noise</b>	68 decibels
<b>Machine weight</b>	1650 Kg
<b>Power Supply (kW-V-Hz)</b>	16amp 3 Phase 5.5kW-400V-50Hz
<b>Overall Dimensions (H x W x D)</b>	3209 x 2115 x 1200mm
<b>Optional Transportation Height</b>	2500mm

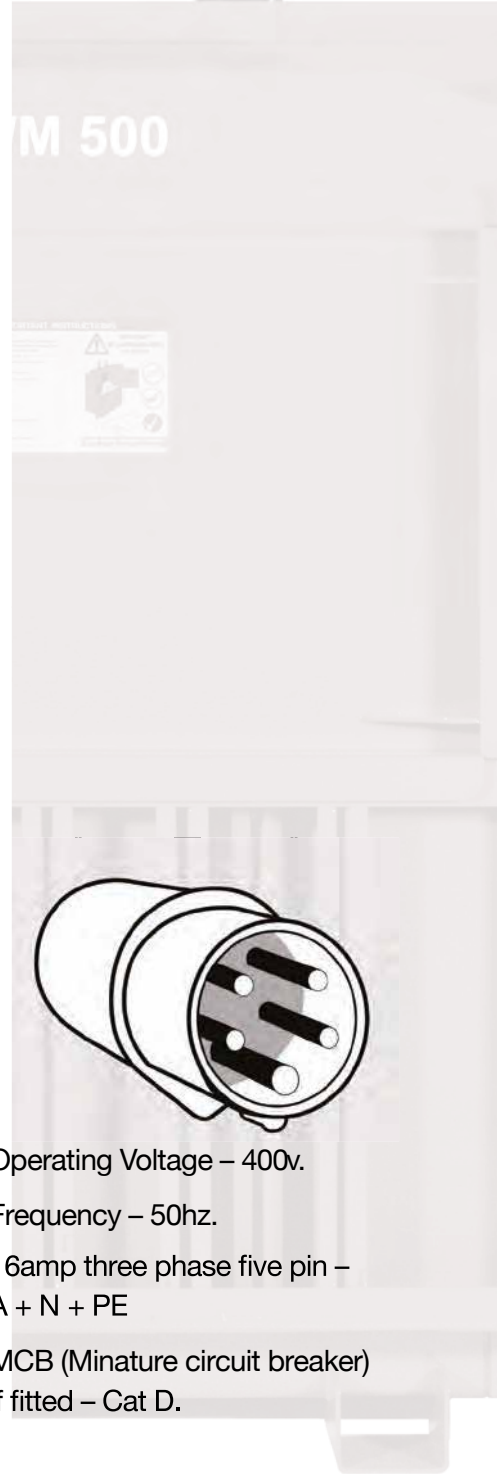

Operating Voltage – 400v.

Frequency – 50hz.

16amp three phase five pin –  
A + N + PE

MCB (Minature circuit breaker)  
if fitted – Cat D.