

HYDRAULIC EXTERNAL VIBRATORS

MODEL VHE

- Rotary Vibrator
- High Amplitude
- Variable Frequency
- Lightweight

On request can be supplied with ATEX certification
To ATEX 95 94/9/EC  II 2 G & D Zone 1, 2 & 21, 22

2 CHAPEL ROAD, PORTSLADE, BRIGHTON, BN41 1PF ENGLAND
Tel. +44(0) 1273 430977 Fax. +44 (0) 1273 430978
Web. www.vibtec.com E-mail. sales@vibtec.com

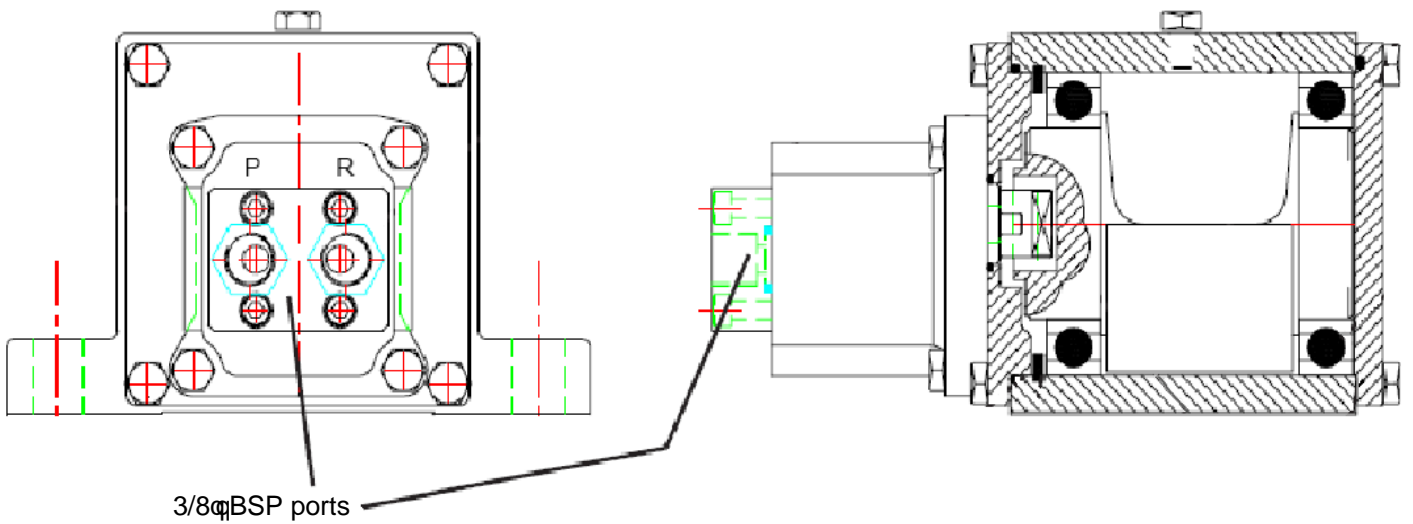
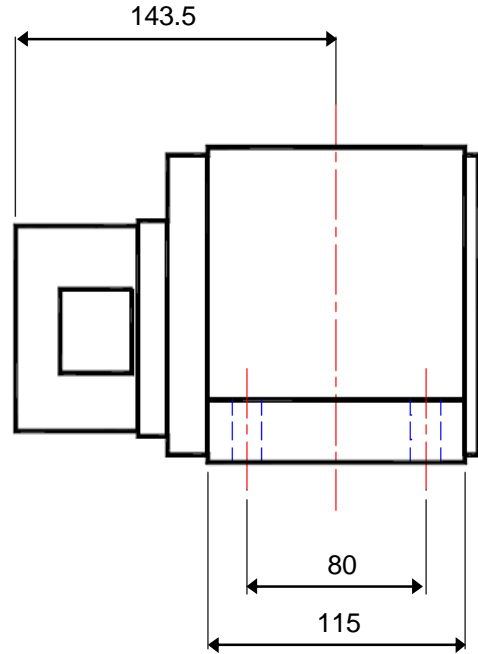
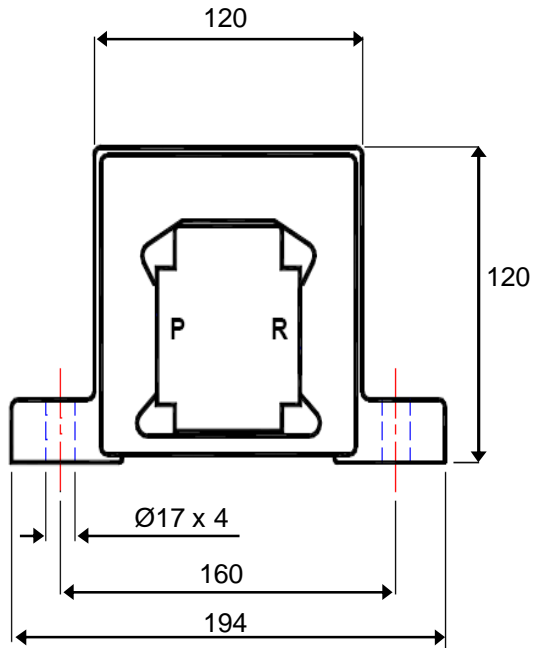

PERFORMANCE DATA

TYPE	Weight (Kgs)	Working Moment (Cm/kg)	Continuous Operation			Intermittent Operation		
			RPM	Force (N)	L/Min	RPM	Force (N)	L/Min
VHE 5/500	6.35	2.05	6000	4065	12	7000	5545	14
VHE 5/900	7.5	6.6	4000	5865	8	5000	9090	10

Oil Pressure : 40 - 100 Bar

1 RPM = 2cc Oil Volume