

VIBTEC

VIBRATECHNIQUES LTD

Vibration Solutions

CE

V150/ V170/ V200 PNEUMATIC IMPACTING VIBRATORS OPERATING MANUAL

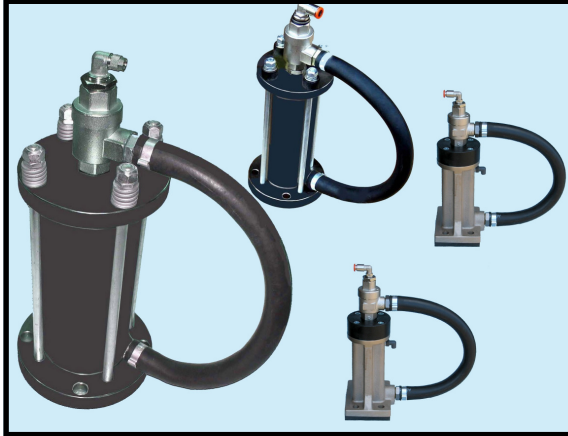

Technical Characteristics

Model	Impact per Min @ 5.5 bar	Air Consumption @ 5.5 bar	Hopper Wall mm	Weight Kgs
V150S	Single Impact	0.8 ltr per impact	2 - 4	3.30
V150C	Continuous Impacts variable from 6-100/min	0.8 ltr per impact	2 - 4	3.80
V170S	Single Impact	1.7 ltr per impact	3 - 5	11.0
V170C	Continuous Impacts variable from 6-100/min	1.7 ltr per impact	3 - 5	11.5
V200S	Single Impact	3.6 ltr per impact	4 - 8	22.0
V200C	Continuous Impacts variable from 6-100/min	3.6 ltr per impact	4 - 8	22.5

IMPORTANT NOTICE

Vibrators and vibrating equipment can be dangerous if not used correctly.

1. **DO NOT** hold or touch when running.
2. **DO NOT** stand or sit on vibratory equipment when running.
3. **USE ONLY** for the purpose intended.
4. **USE ONLY** when vibrators are securely mounted.
5. **USE ONLY** when pneumatic hoses and fittings are securely tightened.
6. **ALWAYS** wear ear protectors.



OPERATING AND MAINTENANCE INSTRUCTIONS

Installation

1. V150, V170 & V200S impacting vibrators are single impacting.
2. They can operate up to 5.5 bar max. via a Filter/Regulator unit (FR). For operating at lower pressure see below.
3. The working temperature should be in the range +5°C - +65°C.
4. The vibrators must be securely mounted to a flat smooth surface.
5. Noise level will exceed 85 dB(A), therefore special precautions must be taken. Using the Damper Kit (supplied as standard with V150 unit) between the vibrator and mounting plate reduces the noise level significantly.



ATTENTION Do not attempt to run vibrator when unattached to a mounting plate. Before starting the vibrator for the first time, ensure all bolts, screws and hose connections are secure.

V150, V170 & V200 - Single Impacting

Setup the vibrators for single impacting (see page 7). Connect vibrators to a manual, electrical or pneumatic operated 3/2 valve. Air on - vibrator is charged, air off - vibrator impacts.

V150, V170 & V200 + Control Unit - Continuous Impacting

Setup the vibrators for continuous impacting (see page 7). Connect vibrators + control units to main air supply via a manual, electrical or pneumatic operated on/off valve. Sequence of impacts from 6 to 100/min can easily be regulated by the control knob inside the Control Unit. It is totally pneumatically controlled.

Converting to operate at lower pressure (3.5 bar - 5.5 bar)

V150

Carefully tap the base of the vibrator down on a piece of wood to remove the piston. Take care not to damage the seal rings. Remove the inner spring and carefully guide the remaining spring, piston and rings back into housing.

V170 & V200

To operate at lower pressure, lift off top plate assembly by removing the 4 off locknuts, washers and rubbers (V170) or springs (V200). Re-assemble without the central inner spring. When tightening the nuts of the V170, the rubbers should be compressed to approx. 18mm. When tightening the nuts of the V200, the springs should be compressed to approx. 26mm.

Maintenance

Generally little maintenance is required if good quality filtered air is used.

1. If vibrator is not to be used for long periods, add a few drops of oil into the exhaust elbow area and run briefly.
2. If necessary the vibrator can be carefully dismantled by unscrewing the 4 bolts. Be careful to note the position of the plain washers, rubber washers and rubber mounts for re-assembling. Carefully part top and base plates from housing, then gently push out the piston ensuring not to damage guides and seals. Carefully wash and clean all the parts with paraffin and re-assemble.

Safety



1. Always ensure compressed air is off during installation or maintenance.
2. Always ensure the air filter is working adequately.
3. Always use locknuts, locking washers or Loctite with fixing bolts to secure the vibrator.
4. Always maintain a regular check on the tightness of the fixing bolts.
5. Always check tightness of hose connections regularly.

V150

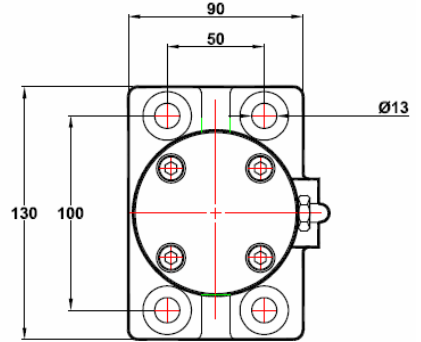
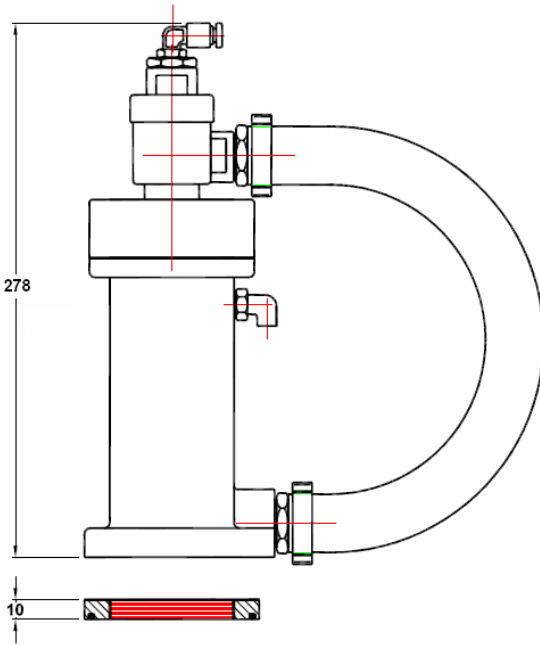

V170/ V200

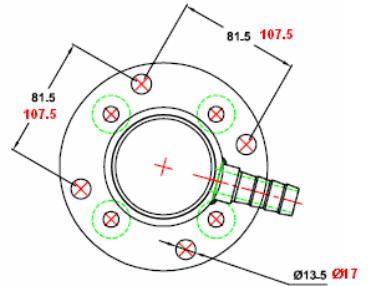
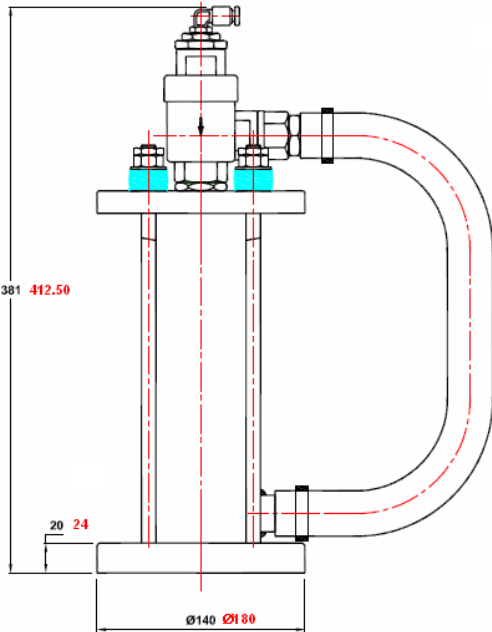

V170/ V200

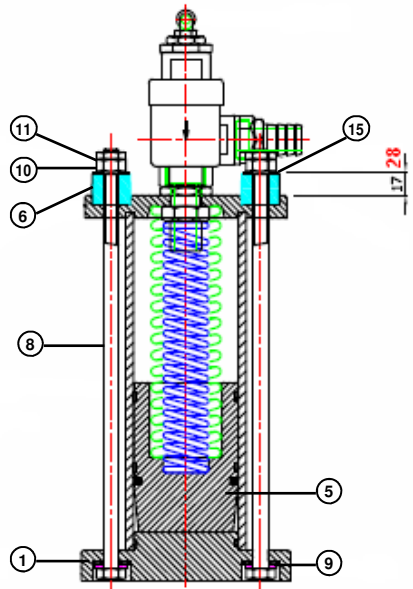
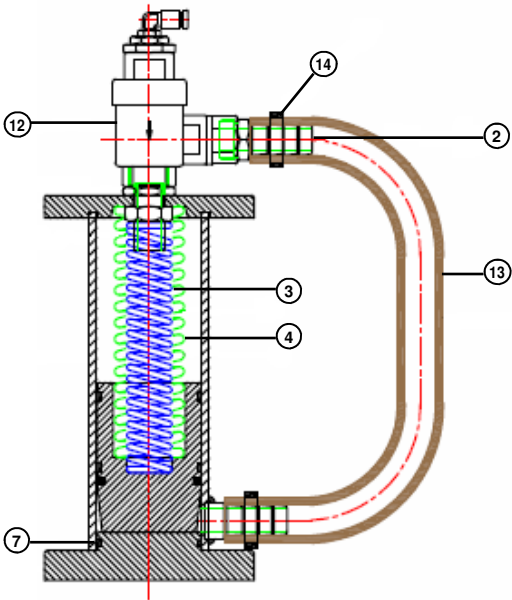

V170

⑤

Part No	Qty	Description
46293	1	PISTON SEAL
46294	2	PISTON GUIDE
45035	1	PISTON
45042 PISTON ASSEMBLY V170		
NOTE SEAL AND GUIDES MUST BE CALIBRATED		

V200

⑤

Part No	Qty	Description
46302	1	PISTON SEAL
46303	2	PISTON GUIDE
45052	1	PISTON
45051 PISTON ASSEMBLY V200		
NOTE SEAL AND GUIDES MUST BE CALIBRATED		

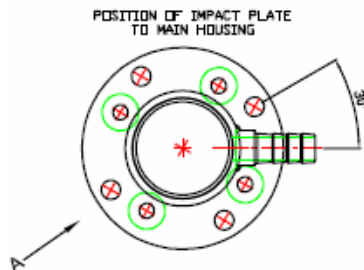

Spare Parts

Ref. No.	Qty.	Description	Part Number	
			V170	V200
1	4	Rubber Washer	45038	45048
2	1	Top Hose Connector	45039	45039
3	1	Inner Spring	45040	45049
4	1	Outer Spring	45041	45050
5	1	Piston Assembly	45042	45051
6	4	Rubber Mount Ø25 x I/D10.5 x 25Lg	45054	N/A
		Die Spring Entex 404	N/A	46304
7	1	'O' Ring I/D 64 x 3 Section	46296	N/A
		'O' Ring I/D 91.67 x 3.53 Section	N/A	16251
8	4	Hex Head Bolt M10 x 280Lg	46297	N/A
		Hex Head Bolt M12 x 330Lg	N/A	46306
9	4	M10/ M12* Plain Washer	46298	46307*
10	4	M10 Full Nut/ M12 Full Nut Type 'C'*	46299	46308*
11	4	M10/M12* Lock Nut	46300	46309*
12	1	Quick Exhaust Valve Seal Kit	46301	46301
13	1	Mandrel Wrapped Hose I/D 19 x Ø32	46349	46349
14	2	Hose Clip	3679	3679
15	4	Mudguerd Washer I/D 10 x Ø25	46346	N/A
		M12 Plain Washer	N/A	46307

V150

①



Part No	Qty	Description
45005	1	DAMPER PLATE
45006	1	DAMPER DISC
46173	1	O RING I/D 80 x 3 SECTION

⑥

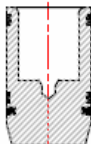

Part No	Qty	Description
46174	1	PISTON SEAL
46175	2	PISTON GUIDE
45001	1	PISTON

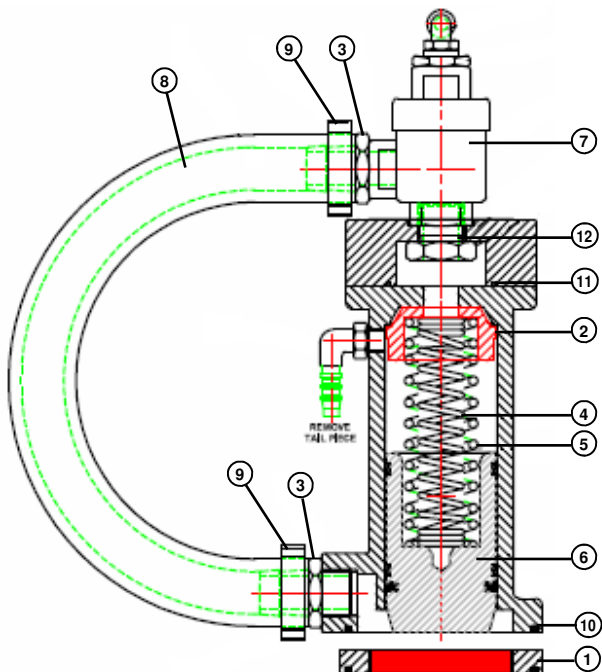

Spare Parts

Ref. No.	Qty.	Description	Part Number
1	1	Damper Kit	45022
2	1	Spring Housing	45003
3	2	Hose Connector	45068
4	1	Inner Spring	45008
5	1	Outer Spring	45007
6	1	Piston Assembly	45020
7	1	Quick Exhaust Valve Seal Kit	46238
8	1	Mandrel Wrapped Hose I/D 19 x Ø32	46349
9	2	Hose Clip	3679
10	1	'O' Ring I/D 80 x 3 Section	46173
11	1	'O' Ring I/D 44.6 x 2.4 Section	6075
12	1	'O' Ring I/D 17 x 2 Section	16314

CONTROL CIRCUITS FOR V150, V170 & V200

Manual control

Main air supply

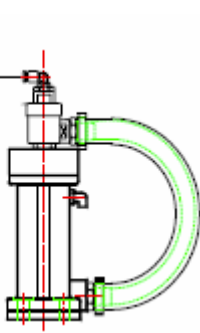

Max. 1000mm

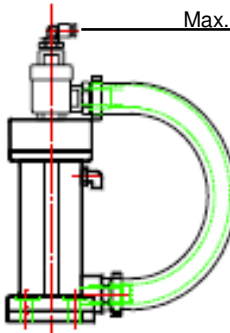

V150, V170 & V200 Single

V150, V170 & V200 + Control Unit

V.I.C CONTROL UNIT

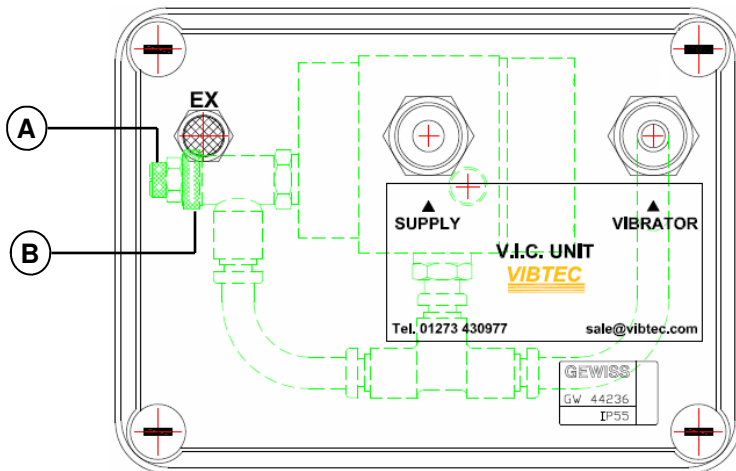

How to regulate Impact Frequency

1. Turn B clockwise to loosen locking ring.
2. Adjust frequency by turning A:
 - Higher frequency - turn anti-clockwise
 - Lower frequency - turn clockwise
3. When required frequency is set, turn B clockwise to lock.

VIBTEC
VIBRATECHNIQUES LTD

Vibration Solutions

2 CHAPEL ROAD, PORTSLADE, BRIGHTON, BN41 1PF ENGLAND

Tel. +44(0) 1273 430977 Fax. +44 (0) 1273 430978

Web. www.vibtec.com E-mail. sales@vibtec.com