

V600 PNEUMATIC INTERNAL VIBRATORS OPERATING MANUAL

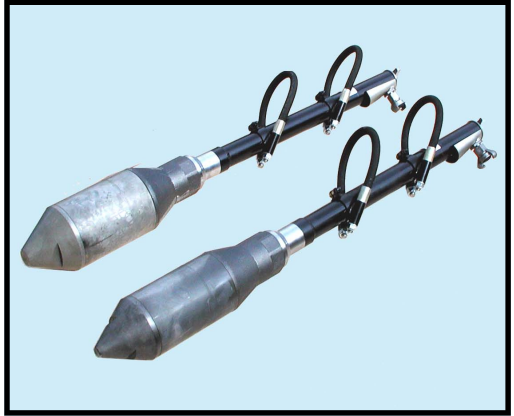

MODEL	V628	V635	V645	V655	V665	V675	V685	V6105	V6140	V6160
Head Diam. (mm)	28	35	45	55	65	75	85	105	140	160
Head Length (mm)	234	278	285	316	327	366	395	395	508	508
Frequency (VPM)	18000	18000	17000	17000	18000	18000	17000	13500	10000	10000
C/F Force (N)	1440	1924	3500	6050	9301	14851	22184	22304	32460	49347
Air Consumption (l/min)	500	608	736	820	1018	1218	1600	2100	2880	3750
Weight (kgs)	4.4	6	8	9	10	15	19	23	35	41.5
Radius of Effectiv. (cm)	16	20	25	38	44	50	55	65	95	105
S P Level (dB)	104.5	107.2	113	109	113	112.1	109	112.2	115	115
Vibration (M.sec ²)	3.2	3	2.74	4.5	4.4	2.24	3.1	4.4	4.8	4.8
Air Pressure (psi)	87									

Sound and Vibration readings taken 1 metre from the poker head
Air Consumption established with supplied pressure of 6 bar

IMPORTANT NOTICE

Vibrators and vibrating equipment can be dangerous if not used correctly.

1. **DO NOT** hold steel vibrating heads when running.
2. **DO NOT** stand or sit on vibratory equipment when running.
3. **USE ONLY** for the purpose intended.
4. **USE ONLY** when pneumatic hoses and fittings are securely tightened.
5. **ALWAYS** wear ear protectors.



General Safety

For your personal protection and safety of others around you on site, please read and ensure you fully understand the following safety information. It is the responsibility of the operator to fully understand how to operate this equipment safely. If you are not sure consult your supervisor.

Points to remember are:

1. Keep unauthorised personnel at a safe distance from the work area.
2. Personal Protective Equipment (PPE) must be worn by the operator whenever this equipment is being used, i.e. Safety goggles, gloves, ear defenders, dust mask and steel toe capped footwear. Always protect skin from contact with concrete.
3. Ensure that the compressor does not exceed 90 psi.



ATTENTION Never use a high pressure compressor.

4. Never dismantle or tamper with any seals or covers fitted. Always check the vibrator thoroughly before use for condition and safety. If any parts are damaged or missing do not use the vibrator until it is repaired or replaced.
5. The air supply must be switched off before any work is carried out on the vibrator. To prevent accidental starting of the vibrator, it must be disconnected from the air supply.
6. The vibrator should never be left running out of concrete as it will become extremely hot and internal parts will be damaged. Caution must be exercised when touching the vibrator head.
7. When the vibrator is not used for long periods of time, store it in a clean, dry and protected environment. It must be hung up with the head upwards and the control handle open to allow moisture etc. to escape from the vibrator.
8. Some vibration from vibrator is transmitted through the flexible hose to the operator's hands. The hose should not be held within 1 metre from the head of the vibrator at any time. Operational exposure time may need limiting if fingers become effected.
9. Do not operate the vibrator when you are feeling unwell, tired or when under the influence of alcohol or drugs.

OPERATING AND MAINTENANCE INSTRUCTIONS

Models V 628, 635, 645, 655, 665, 675, 685 & 6105



General Maintenance

1. Vibrators are delivered without lubrication. Ensure to add oil before starting the vibrator.
2. Before connecting the vibrator, ensure the air line is clean from any water or dirt it may contain.
3. Refill lubricator after every four hours of use with 20/30 S.E.A. non-detergent oil.
4. To start the vibrator it may be necessary to tap the vibrator's hardened nosepiece onto a firm surface.
5. After use, hang the vibrator with the head upwards and leave the control handle open to drain out of any water or dirt.

Dismantling and Re-assembly Instructions

1. Replacement of Vane and Rotor

Hold housing (4) in a vice and unscrew nosepiece (1A) - right-hand thread. Remove from the vice and by angling downwards the rotor is free to drop into the hand ensuring not to cause damage. The parts should be cleaned and examined. If the nosepiece shows signs of excessive wear, then it should be replaced (see point 4). Vanes must be a snug sliding fit in the rotor and fitted so that the vane cuts-out face away from the milled slot in the rotor. Adjust length of vane to 0.1 - 0.15mm shorter than the rotor.

Re-assembly is opposite to the above, but the following should be observed:

1. Lightly oil running faces of the rotor.
2. Insert rotor so that the exhaust holes are in opposite end to the nosepiece.
3. Fit a new 'O' ring or fibre washer (2) onto the nosepiece (1A).

Note

Some models (V665-V6105) have nosepieces (1) and separate front closure plates (3). Dismantling is similar to the above and these two parts are available as spares.

2. Removal of Rear Body, Rear Closure Plate and Hoses

Cut exhaust hose clip (16), pull off exhaust hose (15) from exhaust body (17). Unscrew exhaust body (17) from lubricator/handle (39/30), then pull out handle to expose hose clip (10). Cut hose clip (10) to release inlet hose (11) from the handle. Hold housing (4) in a vice and unscrew rear body (12) - left-hand thread, removing complete with exhaust hose (15). If the hose is to be replaced then unscrew hose sleeve (13), pull out hose (15) from rear body (12) and remove hose protection spring (14) - only on models V675 - V6105. Using inlet hose (11) pull out rear closure plate (7), locking ring (8) and inlet hose connector (9). All parts should be cleaned and the rear closure plate (7) examined for signs of wear (see point 4).

3. Re-assembly

Rear closure plate (7), inlet hose fitting (9) and inlet hose (11) should be inserted into the housing as an assembly, ensuring that the plate is kept square to the housing (4) and pushed onto the housing shoulder. Slide new locking ring (8) over inlet hose (11) and locate behind rear closure plate (7). If necessary, fix exhaust hose (15) into rear body (12), insert hose protection spring (14) - only models V675 - V6105, and clamp with hose sleeve (13). The assembly can then be screwed onto the housing (4) ensuring that a new 'O' ring or fibre washer (2) is fitted. Adjust hose lengths so that the inlet hose (11) protrudes approximately 65mm from the exhaust hose (15). Slide new clips (10 & 16) onto respective hoses (11 & 15). Pass inlet hose (11) through exhaust body (17) and fit onto inlet hose connector (18) using hose clip (10). Screw exhaust body (17) onto control handle (30). Push exhaust hose (15) onto exhaust body (17) and fit hose clip (16).

4. Wear Criterion

The optimum condition of the vibrator turbine assembly to produce maximum speed and therefore power is determined by the total air gap of the rotor. Ideally this should be between 0.06 - 0.13mm and a total gap greater than 0.20mm greatly impairs the performance. The length of the rotor is 129.00 - 129.02mm when assembled at the factory and if worn below 128.70mm, it should be replaced.

Models V 628, 635, 645, 655, 665, 675, 685 & 6105

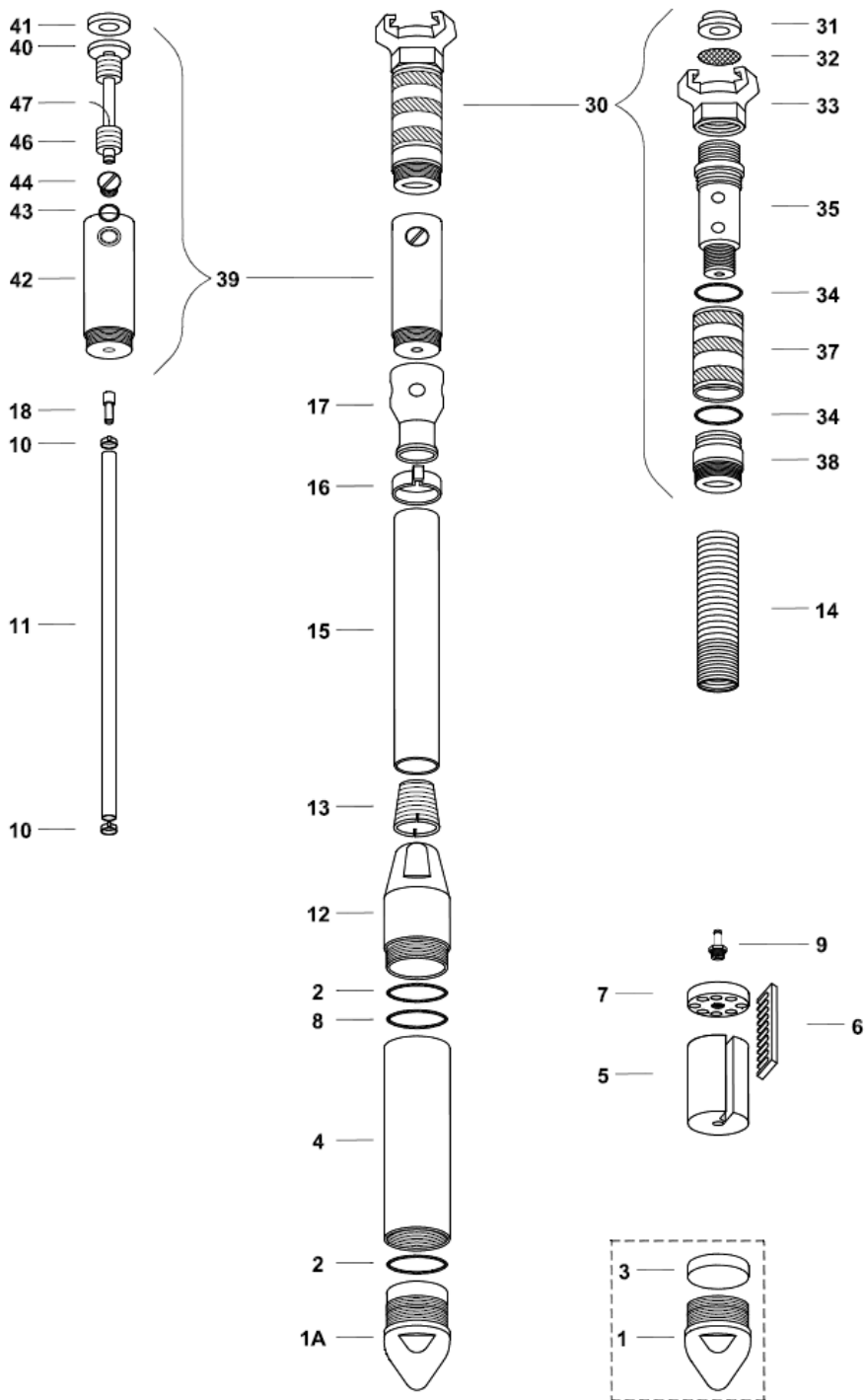

Spare Parts

Ref.	Description	Qty.	V628	V635	V645	V655	V665	V675	V685	V6105
1	Nosepiece	1	-	-	-	-	16265	3551	1602	16246
1A	* 1part Nosepiece / FC plate	1	16310	16206	16216	16227	-	-	-	-
2	* 'O' Ring	2	16314	779	1808	2126	16268	2330	1600	16251
3	* Front Closure Plate	1	-	-	-	-	16260	16230	16380	16240
4	Housing	1	16301	16201	16211	16221	16261	16231	16381	16241
5	Rotor	1	16302	16202	16212	16222	16262	16232	16382	16242
6	* Vane	1	16303	16203	16213	16223	16263	16233	16383	16243
7	* Rear Closure Plate	1	16304	16204	16214	16224	16264	16234	16384	16244
8	* Locking Ring	1	16307	16134	7704	7663	16267	7688	-	16252
9	Inlet Hose Connector	1	-	-	5521	16225	16225	16235	16245	16245
10	Inlet Hose Clip	2	16313	137	137	5456	5456	5211	5211	5211
11	* Inlet Hose	1	46073	788	788	1583	1583	540	540	540
12	Rear Body	1	16306	2622	7701	1576	16266	3553	1601	16247
13	Hose Sleeve	1	-	2623	1730	1582	1582	1604	1604	1604
14	Hose Protection Spring	1	-	-	-	-	-	1479	1479	1479
15	Exhaust Hose	1	171	2021	7985	1584	1584	541	541	541
16	* Exhaust Hose Clip	1	Bandit	3679	2392	75	75	76	76	76
17	Exhaust Body	1	16040	10225	10224	10223	10223	10222	10222	10222
18	Inlet Hose Connector	1	16311	10588	10588	10221	10221	10219	10219	10219
30	Steel Handle Complete	1	16120	16120	16120	16120	16120	16120	16120	16120
31	* Rubber Gland	1	81	81	81	81	81	81	81	81
32	* Gauze Filter	1	156	156	156	156	156	156	156	156
33	Q / R Coupling	1	2512	2512	2512	2512	2512	2512	2512	2512
34	* 'O' Ring	2	2273	2273	2273	2273	2273	2273	2273	2273
35	Handle Shaft	1	2261	2261	2261	2261	2261	2261	2261	2261
37	Twist Grip	1	2260	2260	2260	2260	2260	2260	2260	2260
38	Adaptor	1	16042	16042	16042	16042	16042	16042	16042	16042
39	Lubricator Complete	1	10270	10270	10270	10270	10270	10270	10270	10270
40	Lubricator Tube	1	10289	10289	10289	10289	10289	10289	10289	10289
41	'O' Ring	1	10273	10273	10273	10273	10273	10273	10273	10273
42	Lubricator Body	1	10271	10271	10271	10271	10271	10271	10271	10271
43	'O' Ring	1	2524	2524	2524	2524	2524	2524	2524	2524
44	Oil Filler Screw	1	2265	2265	2265	2265	2265	2265	2265	2265
46	Felt	9	2520	2520	2520	2520	2520	2520	2520	2520
47	Bleed Wire	1	2521	2521	2521	2521	2521	2521	2521	2521
Opt.	Rubber Nosepieces	1	-	16208	16218	16229	19145	3611	-	-

* Most frequently needed parts



OPERATING AND MAINTENANCE INSTRUCTIONS

Models V6140 & V6160

General Maintenance

1. Vibrators are delivered without lubrication. Before using the vibrator ensure to add 20/30 S.E.A. non-detergent oil.
2. Before connecting the vibrator, ensure the air line is clean from any water or dirt it may contain.
3. These models do not have any oil reservoir thus it is essential to use an air line lubricator.
4. To start the vibrator it may be necessary to tap the vibrator's hardened nosepiece onto a firm surface.
5. After use, it is important that the vibrator is filled with 60ml of oil and run for 30sec. before storage.
Then hang the vibrator with the head upwards and the on/off valve open to drain out of any water or dirt.

Dismantling and Re-assembly Instructions

1. Replacement of Vane and Rotor

Hold housing (3) in a vice and unscrew nosepiece (1) - right-hand thread. Remove front plate (7) using 16mm extractor. This allows the rotor (5) and vane (4) to be removed for inspection for wear and damage. Vanes must be a snug sliding fit in the rotor and fitted so that the vane cuts-out face away from the milled slot in the rotor. Adjust length of vane to 0.1 - 0.15mm shorter than the rotor.

Re-assembly is opposite to the above, but the following should be observed:

1. Lightly oil running faces of the rotor.
2. Insert rotor so that the exhaust holes are in opposite end to the nosepiece.
3. Fit a new 'O' ring (2) onto the nosepiece (1).

2. Removal of Rear Body

Undo nut (36) and remove handle (35), then undo nut (24) and clamp nut (21). You can then unscrew rear body (6) - left hand thread. Should the rear plate (8) need to be removed, this can be pressed out. You will need to remove the rotor first from the vibrator to do this.

Re-assembly is opposite to the above, but in order to refit the clamp nut (21), you will need to use M12 female extractor to slightly stretch the inlet hose (17) to line up the thread with the hole in the tube. Once the clamp nut has been fitted, the rest of the handle can be assembled.

3. Removal of Bush

Hold handle tube (34) in a vice and unscrew nut (10) - right-hand thread. Unscrew locking nut (13) - left hand thread, the tube will now separate from the rubber bush (14). To fit a new bush (14), replace the locking nut (13) and push new bush into place. Then place tube with the new bush into the rear body (6) and refit nut (10).

4. Wear Criterion

The optimum condition of the vibrator turbine assembly to produce maximum speed and therefore power is determined by the total air gap of the rotor. Ideally this should be between 0.06 - 0.13mm and a total gap greater than 0.20mm greatly impairs the performance. The length of the rotor is 110.00mm when assembled at the factory and if worn below 109.70mm, it should be replaced.

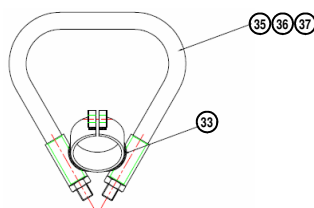

V6140

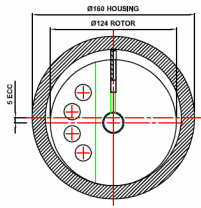
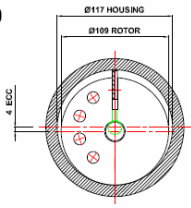

V6160

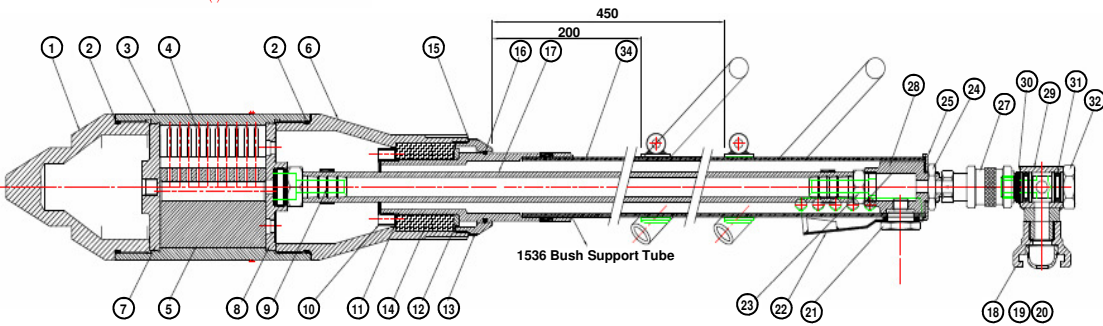

Spare Parts

Ref.	Description	Qty.	V6140	V6160	Ref.	Description	Qty.	V6140	V6160
1	* Nose piece	1	7500	16393	24	Lock Nut	1	1564	1564
2	'O' Ring	2	1534	16395	25	Cover	1	16430	16430
3	Housing	1	7501	16388	27	Slide Valve	1	46155	46155
4	Vane	1	16353	16394	28	Rear Inlet Body	1	16432	16432
5	Rotor	1	7503	16389	29	Exhaust Banjo Fitting Assy	1	16429	16429
6	Rear Body	1	1533	16390		Exhaust Banjo Sleeve	1	16433	16433
7	* Front Closure Plate	1	7502	16392		Exhaust Banjo Inlet	1	16434	16434
8	* Rear Closure Plate	1	7504	16391	30	External Circlip	1	16180	16180
9	Inlet Hose Connector	1	1528	1528	31	'O' Ring	2	16181	16181
10	Nut (bush support tube)	1	1539	1539	32	Banjo Spindle	1	16431	16431
11	Front Spacer	1	1542	1542	33	Handle Clamp Assy	2	16355	16355
12	Rear Spacer	1	1544	1544		Tube (flexible handle)	2	1555	1555
13	Nut (rear body)	1	1538	1538		Clamp Collar	2	16367	16367
14	Bush (shock absorbing)	1	1540	1540		Hex Head Screw	2	16373	16373
15	Sealing Ring Rear	1	1541	1541		Hex Nyloc Nut	2	16374	16374
16	'O' Ring	1	2330	2330		M8 Plain Washer	2	46017	46017
17	* Inlet Hose	1	2021	2021	34	Support Tube Assy	1	16363	16363
18	Quick Release Joint	1	1654	1654		Bush Support Tube	1	1536	1536
19	* Rubber Gland	1	81	81		Rigid Exhaust Tube	1	16364	16364
20	* Gauze Filter	1	156	156	35	Flexible Handle Assy	2	1657	1657
21	Exhaust Shield Clamp Nut	1	16428	16428		Flexible Handle Connector	2	1556	1556
22	Exhaust Deflector	1	1646	1646	36	Hex Nyloc Nut Thin Type	4	1559	1559
23	Hose Fitting	1	1636	1636	37	M14 Plain Washer	4	16372	16372

* Most frequently needed parts

VIBTEC
VIBRATECHNIQUES LTD

Vibration Solutions

2 CHAPEL ROAD, PORTSLADE, BRIGHTON, BN41 1PF ENGLAND

Tel. +44(0) 1273 430977 Fax. +44 (0) 1273 430978

Web. www.vibtec.com E-mail. sales@vibtec.com