

NEW Circulaire 650FDS

Compact Formalin Dispensing Station

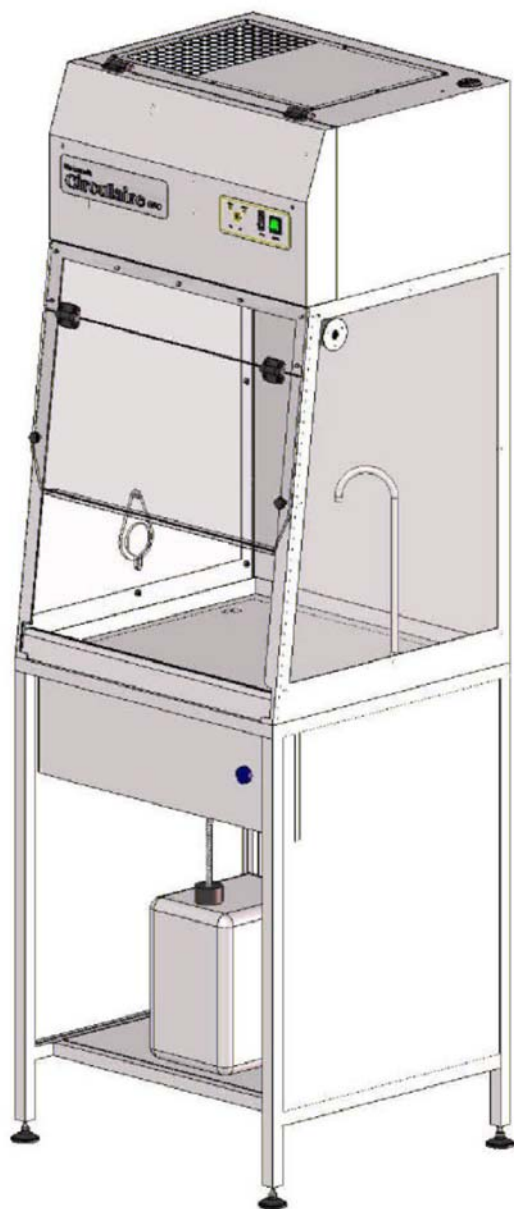

Specification:

External Dimensions mm (WxDxH):	650 x 600 x 1982
Internal Dimensions mm (WxDxH):	600 x 600 x 760
Working Aperture mm (WxH):	590 x 300
Face Velocity:	0.5 m/sec
Airflow:	320 m ³ /hr
Carbon Filter Type:	FORMALIN
Filter Size mm (WxDxH):	600 x 400 x 115
Filter Weight:	14kg
Pre-Filter:	Filtrete
Internal Lighting:	18 watt fluorescent
Fan:	Centrifugal, Brushless & Sparkless
Noise Level:	<57 db(A)
Electrical Supply:	2 x 240v – 400watts
Construction:	Head: Epoxy Powder Coated Zintec Steel with 6mm clear acrylic front and side upper panels.

The new Circulaire 650FDS provides a compact and safe solution to the dispensing of Formalin in Operating Theatres and Pathology Laboratories.

It is free standing and has a footprint of less than 0.4m². It is extremely simple to use, just place your container of formalin into the base section, connect up and press the front mounted button (or optional foot switch) to dispense the formalin through the tap.

The upper cabinet provides full fume containment making sure that all formalin fumes are kept well away from the operator. The large capacity carbon filter ensures that no fumes are returned into the working area. This filter provides 2 to 3 years of life under normal use and is extremely easy to change when required.

Monmouth Scientific

Monmouth Scientific

Unit B4, Bath Bridge Business Park, Bath Road,
Bridgwater, Somerset TA6 4SZ, United Kingdom
Tel: +44 (0)1278 458090 Fax: +44 (0)1278 458091
Email: info@monmouthscientific.co.uk

Monmouth Scientific is a trading division of Monmouth Surgical Ltd.

