

## HORIZONTAL LAMINAR FLOW CABINETS

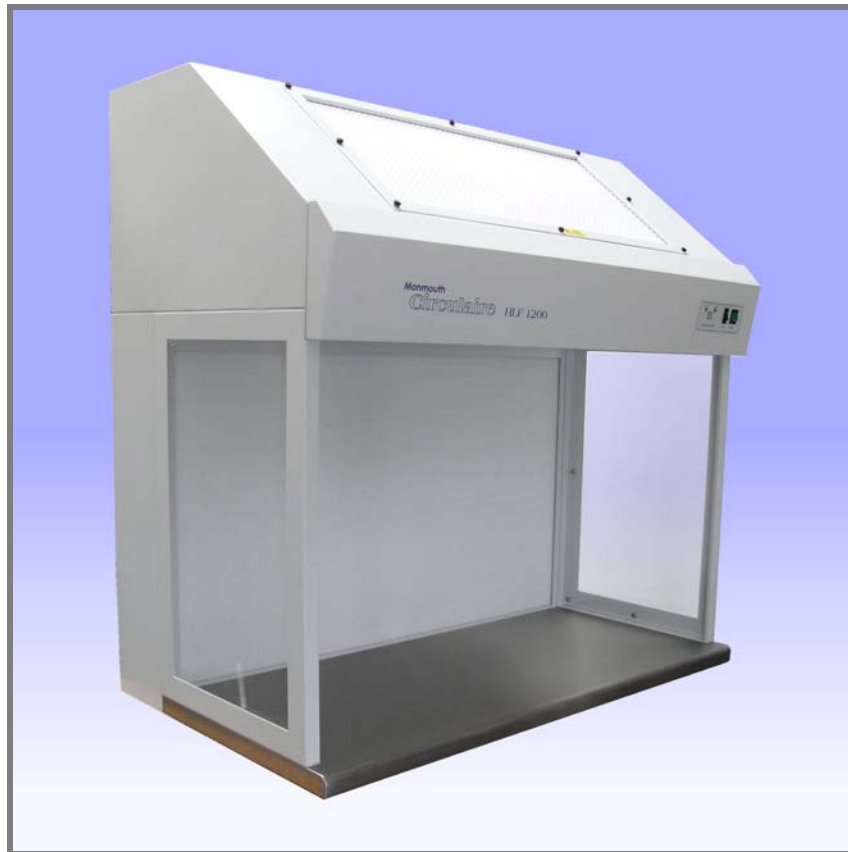

Monmouth's range of Horizontal Laminar Flow Cabinets will provide protection to the working area with a parallel flow of clean HEPA filtered air through filters situated at the rear of the cabinet.

Our standard HEPA filters offer 99.997% efficiency at 0.3 microns which ensures better than Class 100 clean air conditions. Optional ULPA filters offer a greater degree of cleanliness and may be fitted if required.

The fans used in the Monmouth HLF range are large diameter, high performance units with variable speed. This ensures the cabinets are quiet in operation.

A solid 316-grade stainless steel worksurface is provided as standard with a rolled front edge for comfort.

Overhead high intensity lighting is provided as standard (>1000 LUX) to ensure even illumination of the working area.

An optional UV light can be fitted along with a polycarbonate night door to prevent escape of any stray UV lighting. Also available as an option is a base stand or base trolley to sit the cabinet on.

### Monmouth Scientific

Unit D4, Bath Bridge Business Park,  
Bath Road, Bridgwater, Somerset. TA6 4SZ  
Telephone: 01278 458090 Fax: 01278 458091  
Email: [info@monmouthsurgical.com](mailto:info@monmouthsurgical.com) Web: <http://www.monmouthsurgical.com>  
**Registered Office:** Kernow House, Weymont Close, Middlezoy, Somerset, TA7 0JU



## HORIZONTAL LAMINAR FLOW CABINETS

*HLF Control Panel*



### SPECIFICATIONS

	HLF1200	HLF1500	HLF1800
External Dimensions W x D x H - mm	1200 x 720 x 1210	1500 x 720 x 1210	1800 x 720 x 1210
Working area Dimensions W x D x H - mm	1140 x 530 x 740	1440 x 530 x 740	1740 x 530 x 740
Pre-filter EU3	95% efficient @ 0.5um		
HEPA Filter	99.997% efficient @ 0.3um		
Lighting	Fluorescent		
Worksurface	316-grade Stainless Steel with rolled edge		
Noise level	<55db(A)		
UV Light & Interlocked Removable Nightdoor	Optional		
Base Stand / Trolley / Undercupboard	Optional		
Sample protection to BS5295	Confirmed		

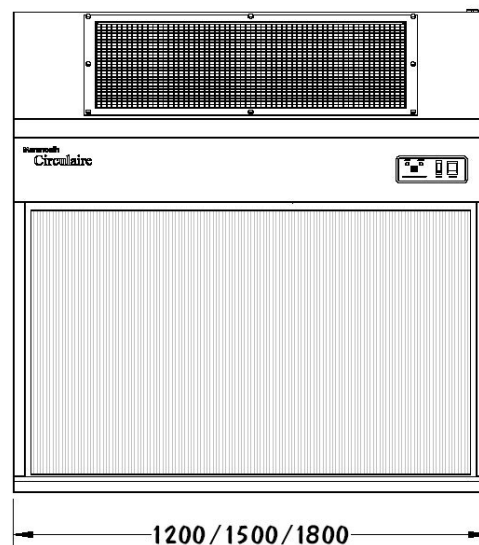
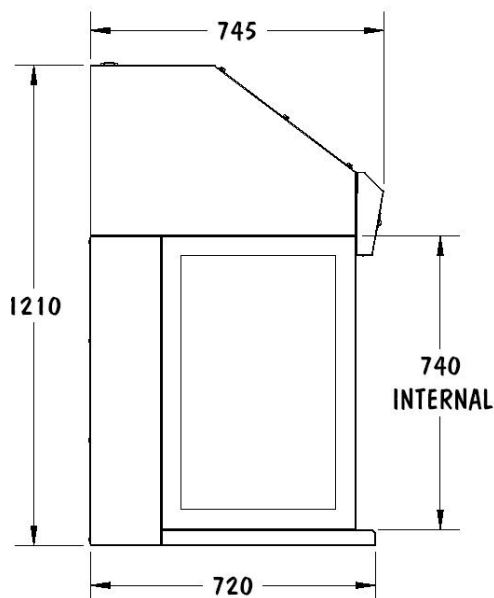

#### Monmouth Scientific

Unit D4, Bath Bridge Business Park,  
Bath Road, Bridgwater, Somerset. TA6 4SZ  
Telephone: 01278 458090 Fax: 01278 458091  
Email: info@monmouthsurgical.com Web: <http://www.monmouthsurgical.com>  
**Registered Office:** Kernow House, Weymont Close, Middlezoy, Somerset, TA7 0JU

