

Technical data for Test-hoses

Ordering code		A	B	C	
Nominal bore (DN)	(mm)	DN 2	DN 2	DN 4	
max. working pressure (PN)	(bar)	400	630	340	
min. bursting pressure	(bar)	1100	1900	850	
Testing pressure	(bar)	600	950	570	
Pressure rating in bar at indicated temperature	at 0° C	(bar)	488	768	463
	at 30° C	(bar)	440	693	418
	at 50° C	(bar)	400	630	380
	at 80° C	(bar)	344	542	327
	at 100° C	(bar)	308	485	293
Working temperature	(° C)	- 35 ... 100 (120)			
Inside diameter	(mm)	2	2	4	
Outside diameter	(mm)	5	5	8,6	
Bending radius	at working pressure	(mm)	20	20	40
	at - 20° C	(mm)	30	30	60
max. coil length	(m)	100	100	100	
Weight/m	(g)	16	16	42	
Inner/outer tube		PA	PA	PA	
Reinforcement		Syntheticfibre	Syntheticfibre	Syntheticfibre	

Hose ends made of 9 S Mn Pb 28 (1.0718), zinc plated and chromated

Stainless steel on request

Ordering code

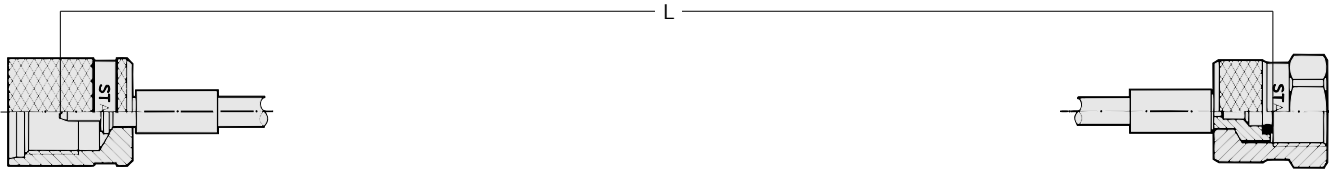

SMS — 20 — / M . . . — 3000 — A

Hose End 1 (see Type page 28 - 31)		
20	A	J
15	S	D
12	K	B
10	L	U
M	G	P
N	F	
W	C	

Hose End 2 (see Type page 28 - 31)



only specify when
2 different hose ends
are required

Length

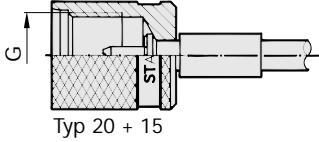
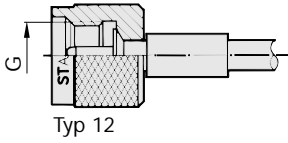
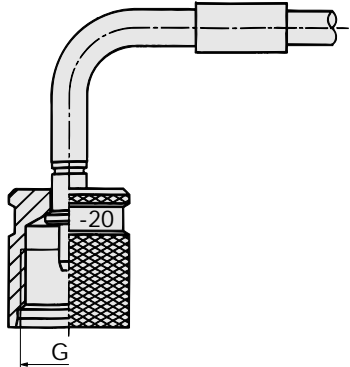

Length in mm
(see L above)

Nominal bore

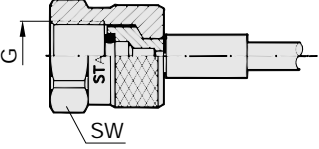
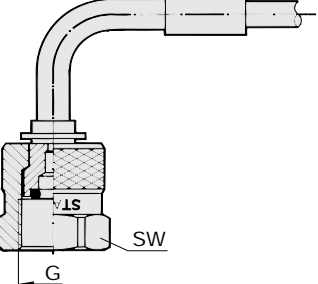
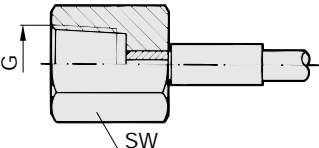
A = DN 2 400 bar
 B = DN 2 630 bar
 C = DN 4 340 bar

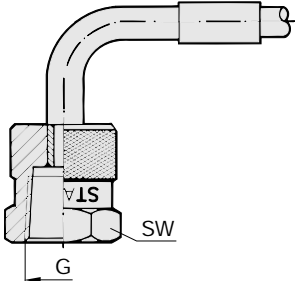
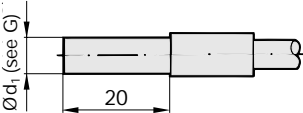
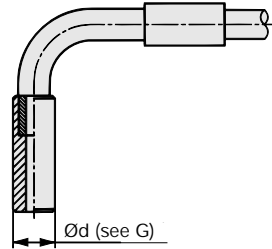
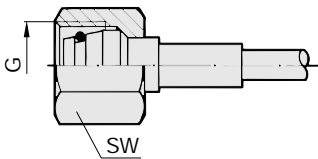
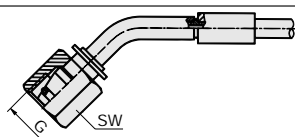
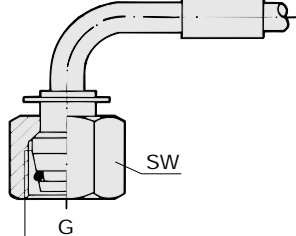
Description	Hose end	Type	G	SW	DN	
STAUFF-TEST Screw-type Suitable for test points	 Typ 20 + 15  Typ 12	O	20	M16 x 2	2 and 4	
			15	M16 x 1,5		
			12	S 12,65 x 1,5		
STAUFF-TEST Screw-type 90° elbow Suitable for test points	 Typ 20	O	20	M16 x 2	2	
			15	M16 x 1,5		
			12	S 12,65 x 1,5		
STAUFF-TEST Plug in-type			10	Plug in system	2	
Gauge adapter BSP-thread for G ³ / ₈ and G ¹ / ₂ BSP swivel nut like type N	 SW	M	1/4	G ¹ / ₄	2 and 4	
			1/2	G ¹ / ₂		
			3/8	G ³ / ₈		2
90° elbow gauge adapter BSP-thread for G ³ / ₈ and G ¹ / ₂ swivel nut like type N	 SW	W	1/4	G ¹ / ₄	2 and 4	
			1/2	G ¹ / ₂		
Gauge adapter NPT-thread for 1/4 NPT swivel nut like type M	 SW	N	1/4	1/4 NPT	2	
			1/2	1/2 NPT		

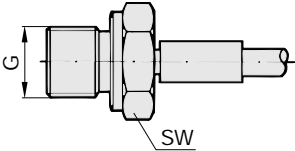
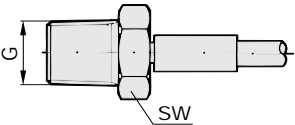
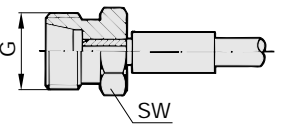
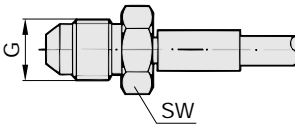
Description	Hose end	Type		G	SW	DN
90° elbow gauge adapter NPT-thread for 1/4"NPT swivel nut like type M		A	1/4	1/4 NPT	19	2 and 4
			1/2	1/2 NPT	27	
Standpipe according to DIN 2353		S	4	4 LL		2
			6	6 L - 6 S		2/4
			8	8 L - 8 S		2/4
			10	10 L - 10 S		2/4
			12	12 L - 12 S		2
			15	15 L		2
			1/4	1/4"		2/4
Standpipe according to DIN 2353 90° elbow		on request				2 and 4
Seal with O-ring for 24° cone fitting according to DIN 2353 c/w swivel nut		K	6 LL	M10 x 1,0	12	4
			6 L	M12 x 1,5	14	2/4
			8 L	M14 x 1,5	17	2/4
			10 L	M16 x 1,5	19	2/4
			12 L	M18 x 1,5	22	2/4
			6 S	M14 x 1,5	17	2/4
			8 S	M16 x 1,5	19	2/4
			10 S	M18 x 1,5	22	2/4
			12 S	M20 x 1,5	24	2/4
Seal with O-ring for 24° cone fitting according to DIN 2353 c/w swivel nut 45° elbow		R	6 S	M14 x 1,5	17	2 and 4
Seal with O-ring for 24° cone fitting according to DIN 2353 c/w swivel nut 90° elbow		L	6 L	M12 x 1,5	14	2 and 4
			8 L	M14 x 1,5	17	
			10 L	M16 x 1,5	19	
			6 S	M14 x 1,5	17	
			8 S	M16 x 1,5	19	
			10 S	M18 x 1,5	24	

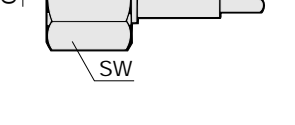
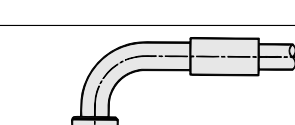
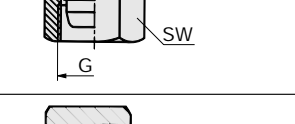
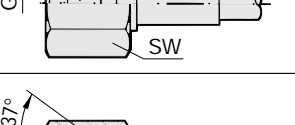
Description	Hose end	Type	G	SW	DN	
Male thread according to DIN 3852		G	12	M12 x 1,5	17	2 and 4
			1/8	G 1/8	14	
			1/4	G 1/4	19	
			1/2	G 1/2	27	
Male thread NPT according to ANSI-Norm		F	1/8	1/8 NPT	13	
			1/4	1/4 NPT	17	
Male thread for 24° cone fitting according to DIN 3852		C	6 L	M12 x 1,5	14	
			8 L	M14 x 1,5	17	
			6 S	M14 x 1,5	17	
			8 S	M16 x 1,5	17	
Male thread according to SAE J 514		J	1/4	7/16 - UNF	14	
			5/16	1/2 - UNF	14	
			3/8	9/16 - UNF	17	
Universal sealing head with swivel nut for 24° cone fitting according to DIN 2353		D	6 L	M12 x 1,5	14	
			8 L	M14 x 1,5	17	
			10 L	M16 x 1,5	19	
			12 L	M18 x 1,5	22	
			6 S	M14 x 1,5	17	
			8 S	M16 x 1,5	19	
			10 S	M18 x 1,5	22	
			12 S	M20 x 1,5	24	
Universal sealing head with swivel nut for 24° cone fitting according to DIN 2353 90° elbow		Q	10 L	M16 x 1,5	19	
			10 S	M18 x 1,5	22	
Sealing head with swivel nut for cone fitting according to DIN 8542		B	1/4	G 1/4	17	
Sealing head with swivel nut according to SAE J 514 37° cone		U	1/4	7/16 - 20 UNF	14	
			5/16	1/2 - 20 UNF	17	
			3/8	9/16 - 18 UNF	19	
Sealing head with swivel nut according to SAE J 514 f 45° cone		UR	1/4	7/16 - 20 UNF	14	

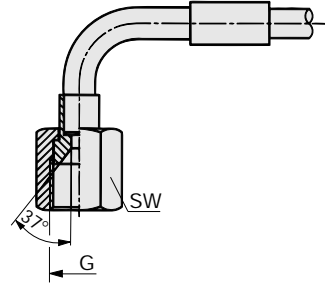
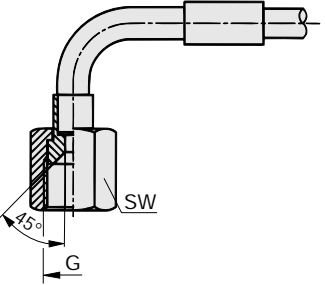
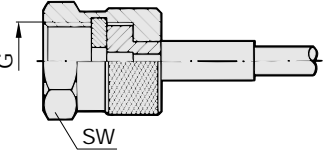
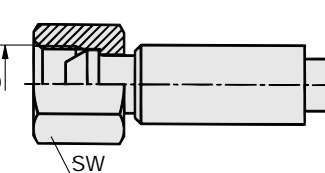
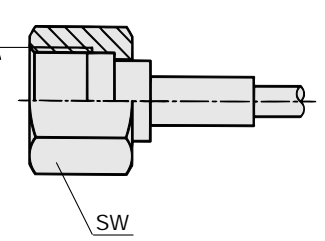
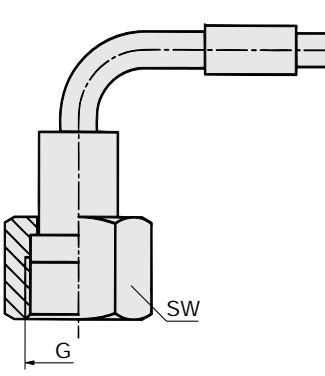
Description	Hose end	Type		G	SW	DN						
Sealing head with swivel nut according to SAE J 514 37° cone 90° elbow		E	1/4	7/16 - 20 UNF	14							
Sealing head with swivel nut according to SAE J 514 f 45° cone 90° elbow			ER	1/4	7/16 - 20 UNF		14	2				
Test hose for air brake systems				P	2		M 16 x 1,5		19			
Sealing head with swivel nut 60° cone					H		1/4		G 1/4		17	4
Screw-type ORS according to SAE J 1453							T		1 1/16		1 1/16 - 16 UN	
Screw-type ORS according to SAE J 1453 90° elbow		V		1 1/16		1 1/16 - 16 UN			21	2 and 4		