

Ultrasonic distance and proximity sensors resistant against chemicals UPR CP Series (PVDF/PTFE housing)

- Measuring range up to 1000mm
- Highly resistant against most chemicals such as acids and lyes
- Housing made of PVDF or PTFE
- Small size
- Measurement irrespective of material, surface, colour and size of target
- Works under dust, dirt, fog, bright light
- Detects transparent and bright objects
- Protection class IP 67, fully watertight, robust
- Customised versions available
- Swiss made precision



Technical specifications

UPR 1003 PSCP ...

Detection range	mm	0 - 1000
Blind range (no reasonable analogue signal)	mm	0 - 180
Adjustment range of switch output (with potentiometer)	mm	180 - 1000
Hysteresis of switch output, axial	mm	60 - 30
Over all accuracy in whole temperature range	%FS	±2
Operating frequency	kHz	180
Status indicator	-	LED red
Switch output, short circuit proof, max. 0.1A	-	by choice PNP, NPN, NO, NC
Switching speed	Hz	7
t _{on} / t _{off} switch output (depending on potentiometer setting)	ms	<100
Analogue output in detection range (Versions)	V	(0) - 10
R _L min. 10kΩ with V output	V	(10) - 0V
R _L max. 500Ω with mA output	mA	(4) - 20mA
Ripple of analogue output	mV	±100
Tracking speed of analogue output	s/95%FS	<0.4
Power supply voltage (polarity reversal protection)	VDC	18 - 33
Ripple of supply voltage	%	<10
Mean consumption, switched without load	mA	35
		version with mA output +20mA
Peak current, switched without load	mA	300mA/0.1ms
Temperature coefficient of sensor	mV/°K	typ. +4
Temperature coefficient of air path	%/°K	-0.17
Ambient temperature during operation	°C	-20°C min 50°C max
Sensor temperature during operation	°C	-20°C min 70°C max
Detection beam angle	°	20 (d.h. ±10)
Pressure range	mbar _{abs}	900 - 1100
Mass without cable	g	120
Protection class	-	IP67
Housing material front part	-	PVDF or PTFE
Housing material rear part	-	Polyamide
Electrical connection	-	M8 connector

www.assemtech.co.uk

Description

The UPR CP series sensors are specially designed for use in a chemically harsh environment. The high resistance is based on PVDF resp. PTFE material. A detailed list of durability is available upon request. A typical application is the level measurement of acids and lyes in smaller containers. The basic sensor is a model UPR 1003 However any UPR series sensor can be built in CP version (see data sheet UPR series). The front part exposed to the medium is made of PVDF (upon request also of PTFE). Both are extremely robust and resistant materials. PTFE is a little more resistant, but softer than PVDF. The outstanding feature is the ultrasonic transducer which is PTFE foil covered. The rear part of the sensor with cable and potentiometer is made of stainless steel resp. polyamide (not resistant against acids).

For OEM applications the shape of the housing can be customised. Actually the following two designs are available as standard products:

- UPR 1003 PSCP 24 ...
- UPR 1003 PSCP 24 ... DAE

Blind range

The lower detection range is called blind range. It is typical for ultrasonic sensors. In the blind range no distance measurement is possible However the pure function as proximity switch (switching output) is possible in the blind range with certain restrictions (only larger objects).

Inclination angle of object

Smooth surfaces can be detected up to an inclination angle of 10°. However rough and structured (granular) surfaces can be detected up to an angle of 60°.

Cable

The sensors have a 3 or 4 pin M8 connector for screw or snap on connection. The cable should be kept as short as possible. Maximum cable length is approx. 100m, if cross section area is appropriate (peak current of 300mA, use 470µF/35V backup capacitor close to sensor). The cable should not be mounted parallel or close to high current cables.

Cables for connection to the M8 connector can be ordered separately.

Mounting

Ultrasonic sensors shall be mounted as soft as possible in order to keep acoustic disturbances away from the mounting spot.

UPR 1003 PSCP 24 ...

Mounting on the flange with 6 M4 screws or mounting on the G1" thread. Sealing with Viton O-rings which are included with the sensor.

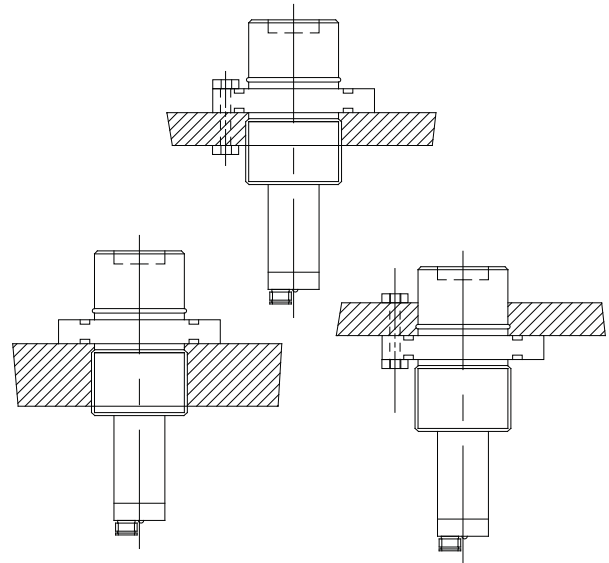

UPR 1003 PSCP 24 ...DAE

Mounting e.g. with a clip.

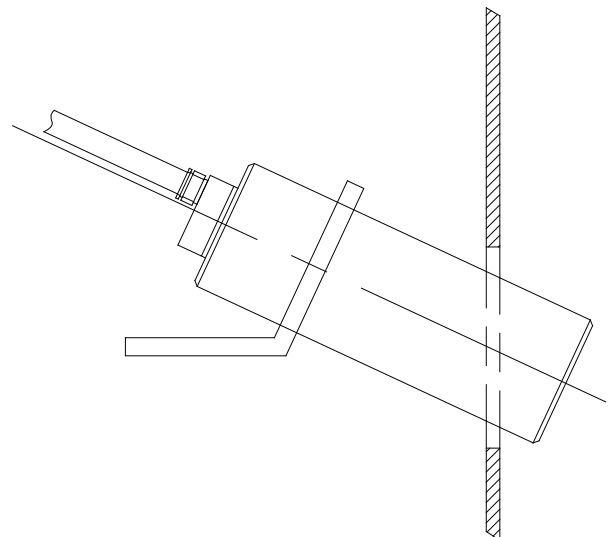

www.assemtech.co.uk

Standard versions

Type	Description
UPR 1003 PSCP 24 A	Shape type UPR 1003 PSCP 24 ..., PNP NO, analogue output 0...10V, 4 pin connector
UPR 1003 PSCP 24 VA	Shape type UPR 1003 PSCP 24 ..., PNP NO, analogue output 10...0V, 4 pin connector
UPR 1003 PSCP 24 I	Shape type UPR 1003 PSCP 24 ..., PNP NO, analogue output 4...20mA, 4 pin connector
UPR 1003 PSCP 24 A DAE	Shape type UPR 1003 PSCP 24 ... DAE, PNP NO, analogue output 0...10V, 4 pin connector

Basically nearly all possible versions are available according to the following key (see also data sheet UPR Series):

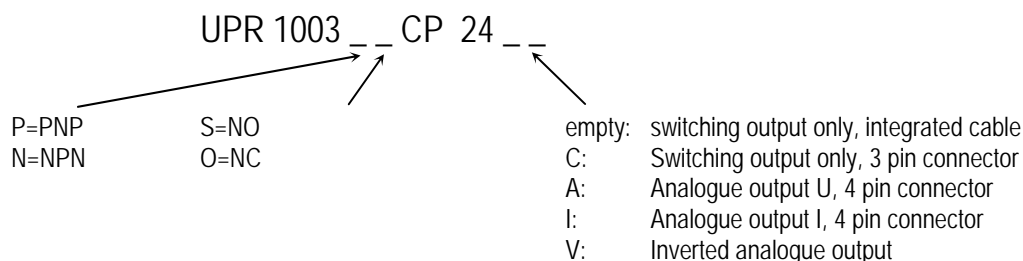

Detection beam

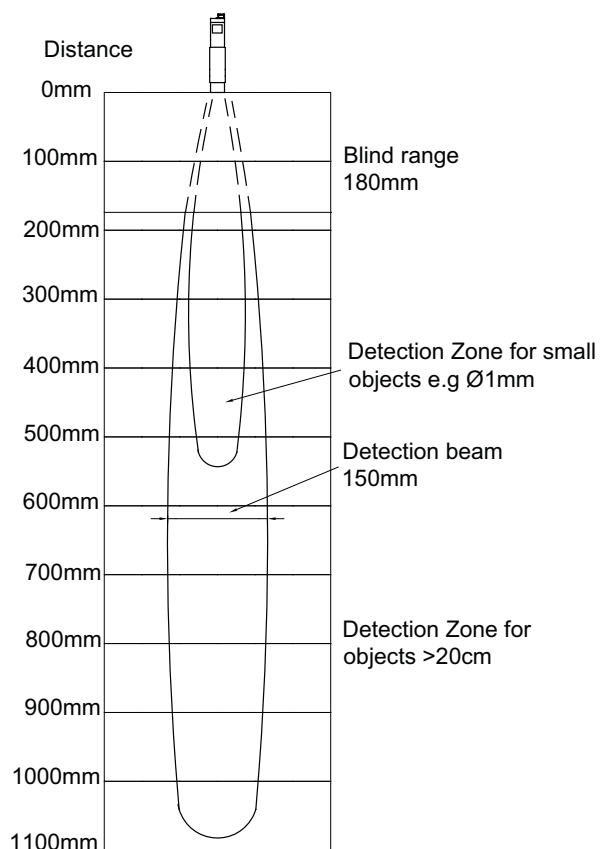

Power supply

Ideally a power supply is used exclusively for the sensor. The power supply must be able supply the short peak current of approx. 300mA for each sensor. In order to avoid disturbances the part where the sensor is mounted must be correctly earthed.

Diagram of connections

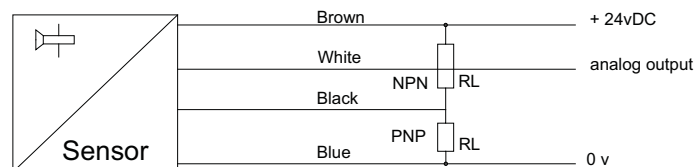

Use appropriate miniature screw driver max. size 2.5mm for adjustment of the potentiometer for switching distance!

Accessories (see also data sheet ,ACC')

Cables 4 pin with M8 screw connector, PUR:

with straight connector: l=2m Type KAB 2K4VGPUR
l=5m Type KAB 5K4VGPUR
with 90° connector: l=2m Type KAB 2K4VWPUR
l=5m Type KAB 5K4VWPUR

Cables 3 pin with M8 screw connector, PUR:

with straight connector: l=2m Type KAB 2K3VGPUR
l=5m Type KAB 5K3VGPUR
with 90° connector: l=2m Type KAB 2K3VWPUR
l=5m Type KAB 5K3VWPUR

www.assemtech.co.uk

Dimensions

UPR 1003 PSCP 24 A:

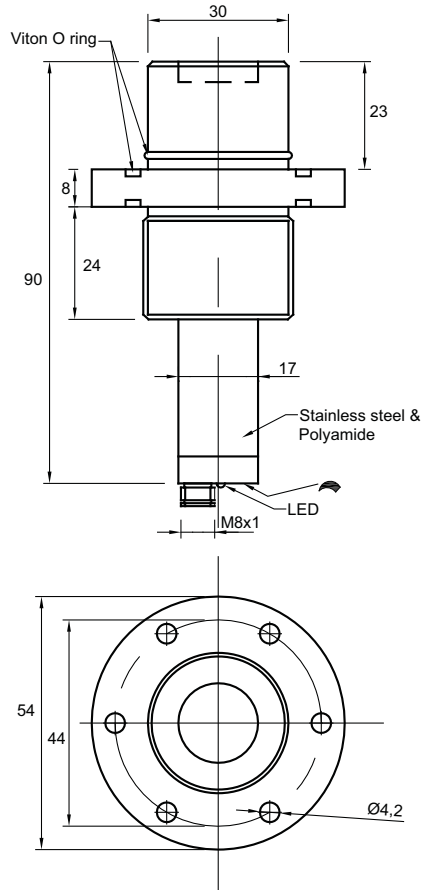

UPR 1003 PSCP 24 A

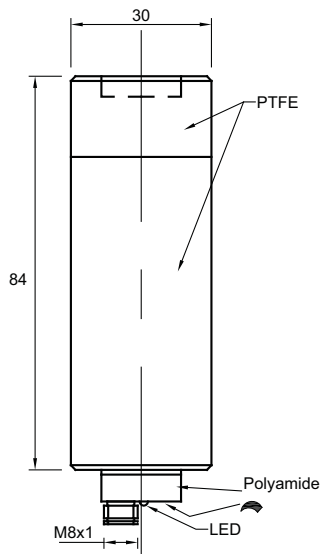

Some typical ultrasound applications

Level measurement

- Measuring level in small containers
- Water gauge measurement
- Monitoring liquid levels in bottling plants
- Checking for tailbacks on conveyor belts
- Monitoring contents of granulate hoppers on injection moulding machines
- Distance monitoring on combine harvesters, beet lifters etc.
- Monitoring ground clearance and distance on agricultural and construction vehicles

Process control

- Controlling & monitoring of belt tension
- Sensing and signaling valve positions
- Measuring roll diameter on reeling machines
- Monitoring the height of stacks (charges, storehouse, assembling machines)
- Detecting material feed
- Detecting the feed of strip stock to blanking machines and presses
- Detecting on plastic blow moulding machines

Counting / Detection

- Counting onlookers at freestanding sales displays or show cases
- Access supervision at rotating doors, counters etc.
- Door automation
- Detecting transparent objects, foils, flat glass, bottles etc.
- Sensing objects in robot grippers
- Recognizing full or empty pallets
- Count and detect objects with 'difficult' surface
- Detect wrong parts on conveyors
- Collision protection on vehicles

Scanning of dimensions

- Determining the dimensions of packages
- Sensing the height of plants in automated green houses
- Measuring the volume of tree-trunks

Parts Included

- Sensor
- 2 Viton O-rings with type UPR 1003 PSCP 24 A

www.assemtech.co.uk