

## Non-contact ultrasonic switch for door automation UPY Series

- Built in the cover of electric switch box (surface mount or flush mount)
- For use where contact by hand is not allowed (e.g. food processing, clean rooms, hospitals)
- Works under dirt, dust, fog, bright light
- Switches irrespective of material, surface, colour and size of target
- Water tight, protection class IP 67, robust
- Reach 30cm (irrespective of target)
- With relay output for connection of a door control unit
- 24VDC operation
- Customised versions available
- Swiss made precision



### Technical data

### UPY 300 RA 24

Detection range	mm	300
Operating frequency	kHz	180
Switch output	-	Relay (1 change switch N/O, N/C)
t <sub>on</sub> Relay	s	0.1
t <sub>off</sub> Relay	s	3
Switch voltage relay	VAC/DC	max. 30
Switch current relay	A	max. 6
Power supply voltage (reversal polarity protection)	VDC	12 - 26
Mean consumption	mA	60
Ambient temperature		-20°C min 50°C max
Protection class sensor	-	IP67
Electrical connection	-	screw-terminal
Color of box cover	-	white

### Description

The ultrasonic switch UPY 300 RA 24 is used instead of a conventional electric wall mounted switch when a non contact operation is necessary (e.g. sliding doors, lights etc.). This complies with certain hygienic demands (food processing industry, hospitals, clean rooms).

The advantage of ultrasonic sensors compared to optical switches is that they are less susceptible to dirt and fully water resistant.

The sensor diaphragm is protected against mechanical wear by an orifice. The orifice can be dismantled for cleaning purposes. The sensor reacts only to presence and not to movements. As soon as an object (e.g. a hand) is within the 30cm detection zone, the built-in relay switches. Since the sensor detects the time of flight and not an intensity (as usual with optical sensors), it has a 100% background suppression. Loads of up to 30VAC/DC and 6A can be switched with the mono stable relay.

[www.assemtech.co.uk](http://www.assemtech.co.uk)

### Electrical connection

A 4 or 5 wire cable can be connected to the sensors screw terminals. Connection (from left to right, see also type label):

- 0V (sensor power supply)
- +24VDC (sensor power supply)
- NC relay out (max. 30V)
- Common relay contact (max. 30V)
- NO relay out (max. 30V)

The relay works as a pulse switch. It switches as long as an object is within the detection range. After that it switches back to its original status after a time delay of approx. 3s. With the relay pulse a control unit can be operated.



Rear view

### Mounting

The UPY switch is offered as one unit together with the box cover (incl. sealing and 4 M3 screws). The box cover fits to a surface mount housing (APG) or to an in-wall mount housing (ELK) as well. For mounting into a wall one needs additionally a mounting plate (MPL).



Surface mount

Flush mount

### Distances

Ultrasonic sensors can mutually influence themselves when they look at each other, therefore do not mount directly opposite to each other. If not possible the following rules should be followed:

- mutual distance min. 3m
- or mounted min. 30cm out of axis

### Detection range

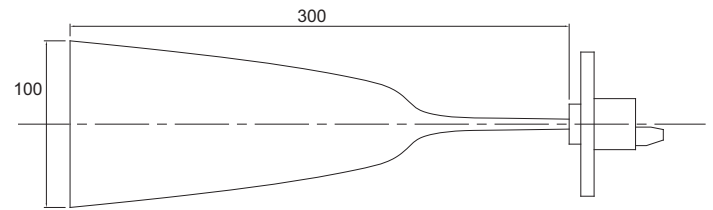

The detection range can be set shorter or longer on customer demand.

### Dimensions

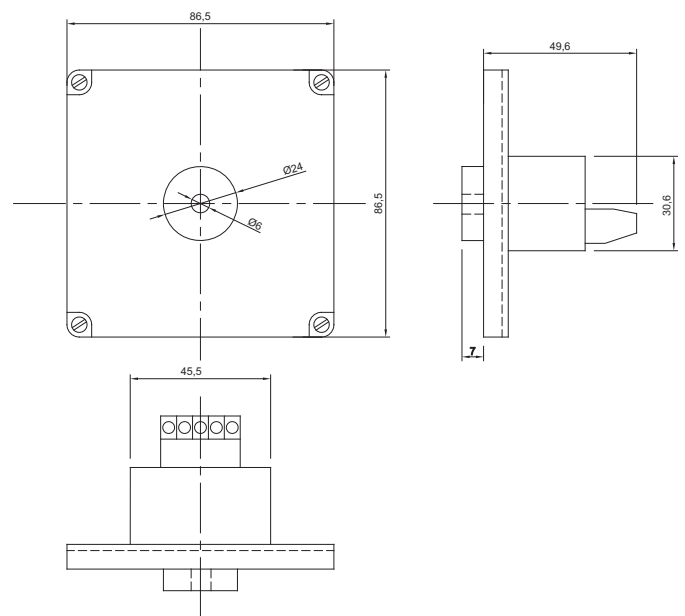

### Accessories

#### For surface mounting:

- Surface mount housing, white 87x87x54mm (WxLxH) Type APG

#### For in-wall mounting:

- In-wall mount housing 78x78x57mm (WxLxH) Type ELK

- Mounting plate incl. sealing for flush mount housing 87x87x7mm (WxLxH) Type MPL