

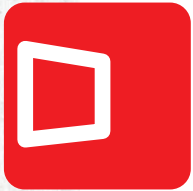

loft access hatches



loft ladders



access panels

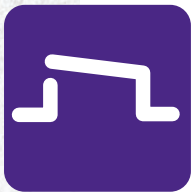

roof hatches



tubular skylights



roof domes



solar entry light



INNOVATION IN ACCESS

# Access Building Products Ltd

Access Building Products Limited is a privately owned company producing and supplying Loft Access Traps, Access Panels and Associated Products to the Private and Public Sectors of the Building Industry, through Distributors and Builder's Merchants.

In our specialist area of work we place high value on:

- fully meeting customers needs
- product quality and reliability
- being cost effective
- reducing lead times
- innovation and product development
- having clear lines of communication
- behaving in an ethically responsible manner
- reducing our carbon footprint as much as possible

In our chosen markets we excel at:

- being competitive in the market place
- packaging and distribution of products
- delivering on time, correct and complete orders

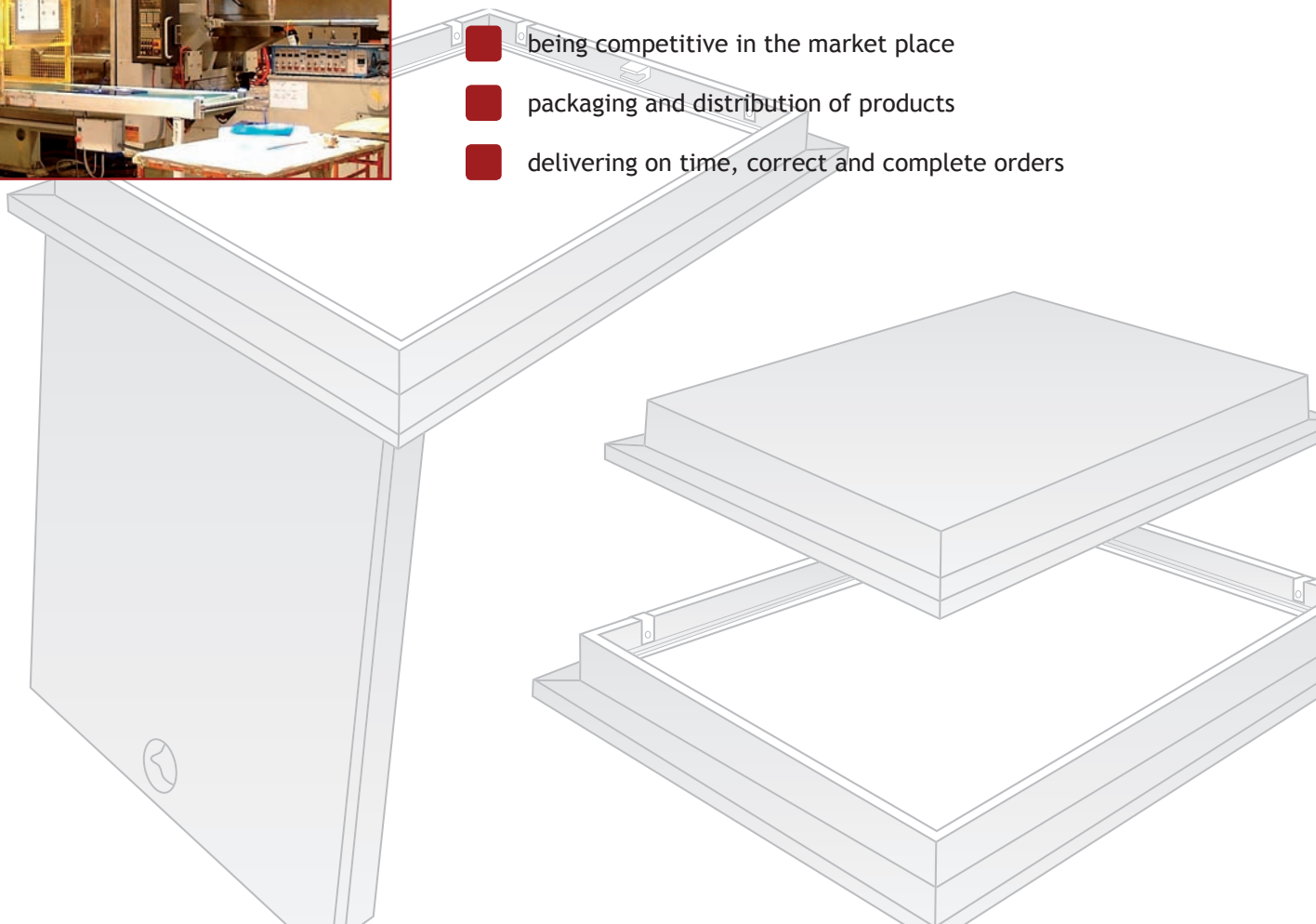
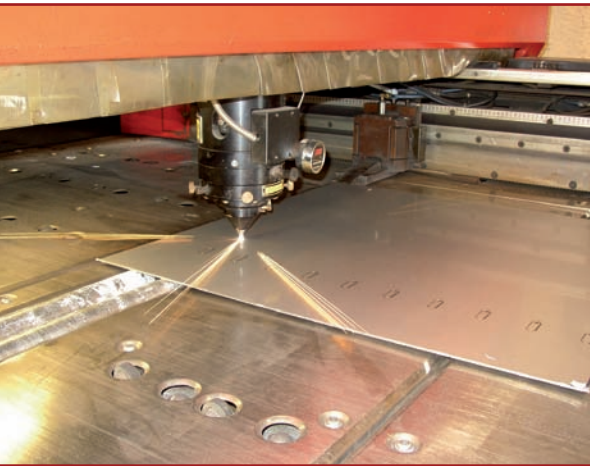





## Loft Hatch Overview

A loft access trap need not be a design statement. It may blend in with modern decor and we have that aesthetic intention at the forefront of our design considerations. The Access Building Products range of traps has a contemporary unobtrusive look, with clean lines that fits almost flush to the ceiling.

Our entire range has a smooth white maintenance free finish. It compliments today's strong trend towards smooth plastered walls and ceilings.

The entire Loft Access Trap range is effective and user friendly. It strictly complies with all relevant performance and environmental standards, as follows:

- UKAS accredited air tightness tested without the need for additional sealant between the external frame and ceiling during installation.
- NHBC compliant as Chapter 7.2 Section D14 "to a minimum clear opening of 520mm in any direction", with "clear opening" referring to the dimensions of an open, installed trap.
- Compliant to Building Regulations Part "L1A" with a minimum overall "U" value of 0.35 (where specified).
- UKAS accredited one hour fire tested (where applicable).

### *In addition*

- The insulation in our range has a global warming potential (GWP) rating of less than 5, is CFC and HCFC free and is ODP zero, complying with all requirements for Ecohomes and the Code for Sustainable Homes.
- All box packaging is made from 100% recycled material and is 100% recyclable. Fitting instructions are printed on the box to save paper.
- Our range offers some of the largest clear opening sizes available.
- All ceiling cutouts (trim sizes) are identical for the PD, PD35, SD & SP2, for uniformity. In the event that the incorrect trap is installed, it is easily remedied by simply exchanging the product.







## The PD *(Plastic Drop-Down)*

Aesthetics for the contemporary orientated, modern house design.

With a high impact styrenic plastic composition, it offers a tough, ultra smooth, white maintenance free finish. It requires no painting and projects a mere 7mm into the ceiling space. The concealed hinges and completely flush "lid to frame" contribute towards its unobtrusive look.

The PD has the largest clear opening available to the market, with flexible fixing tabs to eliminate any twisting during installation. As standard, it is fitted with a neat quarter-turn catch. An access pole attachment to enable opening from floor level is also supplied. We also offer secure key lockable options.

The PD has an inner draught and vapour seal between the lid and frame. It also has a concealed outer seal between the frame and ceiling, negating the need for on site sealant. This saves time, costs and assists in the ease of decoration of the ceiling up to the frame.

In addition to the 100% recycled and recyclable packaging, the PD range is insulated with a bonded EPS blown with agent pentane, giving a GWP rating of less than 5.

Available in versions to comply with part "L" (PD35), to exceed part "L" (PD25) and to the old regulations (PD).

Model	Ceiling Cutout	Clear Opening (Once Installed)	"U" Value	Part "L" Compliant	NHBC Compliant	UKAS Accredited Air Tested	Key Lockable	Weight
PD35	760 x 560mm	630 x 533mm	0.35	✓	✓	✓	-	2.8kg
PD35L	760 x 560mm	630 x 533mm	0.35	✓	✓	✓	✓	2.9kg
PD25	760 x 560mm	630 x 533mm	0.25	✓	✓	✓	-	3.2kg
PD25L	760 x 560mm	630 x 533mm	0.25	✓	✓	✓	✓	3.3kg
PD	760 x 560mm	700 x 533mm	0.77		✓	✓	-	2.8kg
PDL	760 x 560mm	700 x 533mm	0.77		✓	✓	✓	2.9kg





The SD



The SDL

## The SD *(Steel Drop-Down)*

A one hour fire rated trap, which has an attractive contemporary design and many innovative features that set it apart from all other traps, including one of the largest clear openings available to the market.

The durable zintec steel has a powder coated smooth white maintenance free finish, projecting only 7mm into the ceiling space. The concealed continuous hinges and completely flush "lid to frame" offer a simplistic, unobtrusive look.

The SD is fitted with a unique hardened steel quarter-turn catch with a neat tri-drive and built-in chamfer, for a smooth closing action and high compression. The lid weight of only 5.8kg coupled with an access key, allows opening from floor level.

In addition to the inner draught and vapour seal between the lid and frame, a concealed outer seal between the frame and ceiling negates the need for costly on site sealant. This saves time, costs and assists in the ease of decoration of the ceiling up to the frame.

The whole design offers a complete air seal without susceptibility from plastic plugs or grooved locking systems. A secure radial pin tumbler lockable option is available (SDL), with keyed to differ barrels as standard or an option for keyed alike.

Extra to the 100% recycled and recyclable packaging, we utilise a 100mm 45kg/m<sup>3</sup> mineral wool slab, that exceeds both the necessary Part "L" requirements and a GWP rating of 0.

Model	Ceiling Cutout	Clear Opening (Once Installed)	"U" Value	Part "L" Compliant	NHBC Compliant	UKAS Accredited Air Tested	1 Hour Fire Rated	Key Lockable	Weight
SD	755 x 555mm	630 x 520mm	0.32	✓	✓	✓	✓	-	7.6kg
SDL	755 x 555mm	630 x 520mm	0.32	✓	✓	✓	✓	✓	7.6kg



The SDNL

## The SD Specials Range

### SDS:

A made to measure option, with the same qualities as the standard SD in bespoke sizes specific to your requirements.

### SDSS:

Having the same qualities as the SD with a door and frame manufactured from stainless steel. Commonly used in corrosive areas or simply for modern aesthetics.

### SDNL:

A unique option in the building industry. Our SDNL is a loft hatch with an inset window to allow natural light through the loft door from the loft space, via skylights or clear tiles in the roof. The door is fully bonded and insulated with a 25mm five layered opaque polycarbonate sheet giving a "U" value of 1.6 (Please note: This product is not fire rated).

Any of the above are available in a secure radial pin tumbler key lockable option by adding postfix "L"



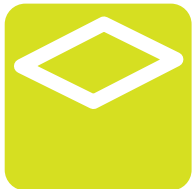

The SP1



The SP2

## The SP *(Steel Push-Up)*

A one hour fire rated loft hatch designed with budget in mind. It is a very cost effective solution to satisfy all today's requirements.

The durable zintec steel has a powder coated smooth white maintenance free finish, projecting only 1mm into the ceiling space giving very simplistic aesthetics, whilst complying to all regulations.

With two sizes available as standard, the SP has an inner draught and vapour seal, with the frame acting as an outer seal. This provides the necessary joint to virtually eliminate air and moisture ingress, without the need for costly on site sealing. This saves time and assists ease of decoration of the ceiling up to the frame.

100% recycled and recyclable packaging is utilised, with 100mm 45kg/m3 mineral wool slab, that exceeds both the necessary Part "L" requirements and gives a GWP rating of 0.

*Bespoke sizes available.*

Model	Ceiling Cut-out	Clear Opening (Once Installed)	"U" Value	Part "L" Compliant	NHBC Compliant	UKAS Accredited Air Tested	1 Hour Fire Rated	Weight
SP1	555 x 555mm	520 x 520mm	0.32	✓	✓	✓	✓	4.8kg
SP2	755 x 555mm	712 x 520mm	0.32	✓	✓	✓	✓	6.6kg





Following our acquisition of the "Banbro" range from Birtley (Bainbridge), we now offer the following options:



## The Laddatrap MK2

(LT2 Plastic Drop-Down)

The Banbro Laddatrap MK2 has a gently decorative frame more suited to refurbishment projects retaining a classic appeal. With a simple thumb-turn the loft hatch offers easy access to the roof space.

The Laddatrap Mk2 loft hatch is an injection moulded unit produced from precision engineered tooling to our own unique design. The high impact polystyrene material offers a perfect combination of strength, rigidity and stability. Once the drop down loft door is opened, it has a large clear opening of 700mmx533mm.

In addition to the 100% recycled and recyclable packaging, the Laddatrap Mk2 is insulated with 35mm of bonded EPS insulation blown with agent pentane, giving a GWP rating of less than 5.



## The Econotrap MK3

(ET3 Plastic Push-Up)

The Banbro Econotrap MK3 loft hatch has a gently decorative frame more suited to the classic look, as opposed to a contemporary style. A simple push-up ceiling door, ensuring remarkable value for money.

The high impact polystyrene material offers a perfect combination of strength, rigidity, stability and consistency. The loft door comes in an attractive, semi-gloss brilliant white finish to blend in naturally with the ceiling. The state of the art production process ensures loft hatches with consistency of quality, colour and finish every time.

The Econotrap Mk3 loft hatch incorporates 4 built-in securing pins, which locate automatically behind the lid when closed. The pins hold the door in position, providing a compression seal against the fitted draught and vapour seals.

The full size dimensions of the ceiling door allow for comfortable access for the homeowner. This will be of benefit for storing bulky items in the loft space, such as suitcases.

In addition to the 100% recycled and recyclable packaging, the Econotrap Mk3 is insulated with 35mm of bonded EPS insulation blown with agent pentane, giving a GWP rating of less than 5.

Model	Ceiling Cut-Out	Clear Opening	"U" Value	Weight
LT2	720 x 560mm	655 x533mm	0.77	2.9kg
ET3	720 x 560mm	690 x533mm	0.77	2.8kg





G: 11.6 - 41.3cm  
 H: 67° - 71°  
 J: 32.8cm

## Loft Ladder Combi

- **Type:** 3 section folding ladder
- **Materials:** ladder - pine wood, casing - spruce
- **Casing:** the lower edge of the casing has a draught excluder, which ensures tight closing
- **Installation:** inside the ceiling
- **Hatch:** 2.0cm spruce frame, 2.0 cm insulation (polystyrene) with white masonite plates on both sides, thickness 2.6cm
- **Treads:** all treads have a non-slip surface and are fitted using dovetail joints
- **Standard Accessories:** metal handrail, plastic feet
- **Additional Accessories:** guardrail, mounting brackets, lining, extension kit
- **Insulation Coefficient:** 1.22 W/m2K
- **Loft Ladders Dimensions:**
  - casing: thickness 1.8cm, height 11.5cm
  - treads: thickness 1.8cm, depth 6.9cm
  - ladder: width 40cm, distance between treads: 25cm
  - maximum swing clearance: 163cm
  - floor to ceiling height: 283cm
- **Maximum Safe Loading:** 150kg

Casing Size (cm)	Opening Size (cm)	Floor-to-Ceiling (cm)	Casing Height (cm)	Number of Treads (cm)	Max Landing Space (cm)	Max Swing Clearance (cm)
117.5 x 57.6	120 x 60	283	11.5	12	140	163
E	D	A	F			C

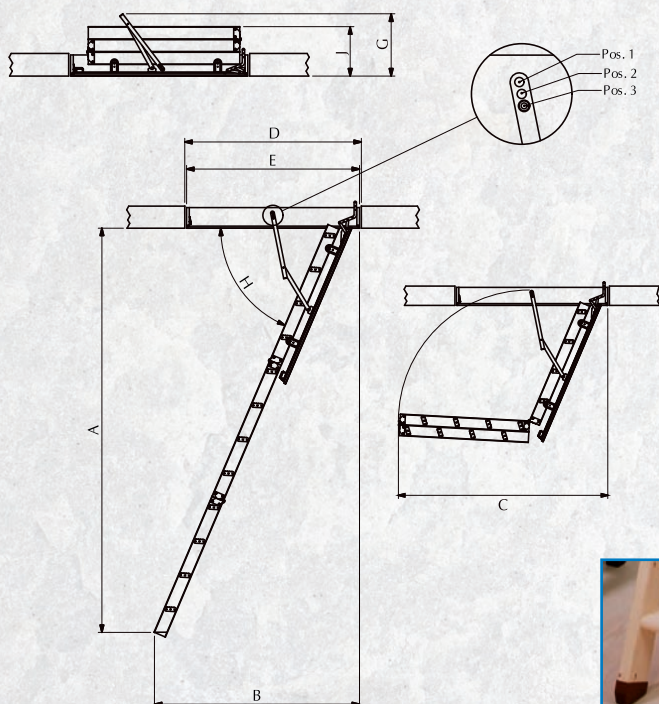

## Accessories



Guardrail



Metal Handrail



Plastic Feet

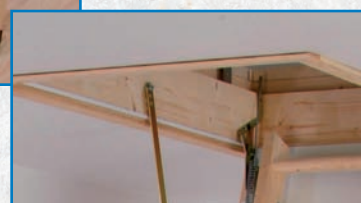

Lining





## AL2



150Kg  
23.6 Stone

EN 14975

*(Aluminium 2 Section Loft Ladder)*

Suitable for heights up to 2.66m (8'9").

Wide non-slip 'D' rungs for comfort and safety.

Unique friction guides for smooth and easy opening.

Suitable for DIY installation. Includes all components and easy to follow instructions.

Suitable for domestic use only.

## AL3



150Kg  
23.6 Stone

EN 14975

*(Aluminium 3 Section Loft Ladder)*

Suitable for heights up to 3m (9'10").

Wide non-slip 'D' rungs for comfort and safety.

Handrail for added safety when entering or leaving the loft.

Unique friction guides for smooth and easy opening.

Suitable for DIY installation. Includes all components and easy to follow instructions.

Suitable for domestic use only.

## AL3C



150Kg  
23.6 Stone

EN 14975

*(Commercial 3 Section Loft Ladder)*

Suitable for heights up to 3m (9'10").

Spring assisted 'Easy Stow' system gives total control when lowering or stowing the loft ladder.

In-loft handrail for added safety when entering or leaving the loft.

Suitable for DIY installation. Includes all components and easy to follow instructions.

Suitable for commercial and domestic use.



AL2 In-Stow

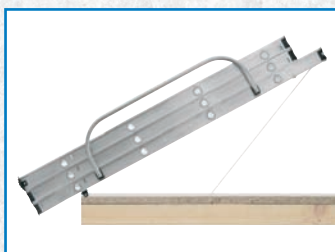

AL3 In-Stow



AL3C In-Stow

Product Code	Sections	Handrail	Max Floor to Loft Height	Min Loft Opening Size Width	Min Clearance Arc	Min Storage Space
AL2	2	0	2.69m (8'10")	0.38m (1'3")	0.71m (2'4")	1.27m (4'2")
AL3	3	1	3m (9'10")	0.38m (1'3")	0.71m (2'4")	1.12m (3'8")
AL3C	3	1	3m (9'10")	0.38m (1'3")	0.71m (2'4")	1.12m (3'8")





# Access Panels

Access Building Products Ltd is an established supplier of high quality access panels, with a range to suit every requirement within the building industry. In addition to our standard and made to measure products, we offer a bespoke design service for custom made requirements.

Our panels allow easy access to wall and ceiling cavities for entry or accessible maintenance, whilst complying with all current building regulations and test standards.



*The Plastic Handi-Access*

Dimensions	Standard	Lockable
100 x 150mm	HA100-150	HA100-150L
150 x 230mm	HA150-230	HA150-230L
200 x 200mm	HA200-200	HA200-200L
350 x 350mm	HA350-350	HA350-350L
560 x 560mm	HA560-560*	HA560-560L

*\*HA560-560 is suitable for use in walls only*

## The Plastic Handi-Access Panels

Our plastic HA panel range provides a simple, low cost, high quality solution for access to building services in walls and ceilings. The injection moulded slim profile produces a lightweight solution, enabling an easy fit installation into all types of wall or ceiling construction.

Produced from UV stable ABS, the white panel will not discolour. However, the surface is lightly textured to accommodate a paint finish, if required.

The door panel is held closed by a snap friction catch. The hinged door can be opened with a flathead screwdriver or a coin in the visible slot, opposite the hinge edge. It is easily removed from the frame without tools, if needed.

Key lockable options are available in all sizes.

Install using a suitable adhesive and simply push into place.

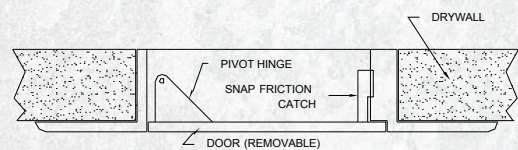

*The Standard Steel Access Panel*

Available in the following standard sizes, with non-standard sizes manufactured to order.

### Picture Frame

Dimensions	Standard	Lockable
200 x 200mm	PFS200	PFS200L
300 x 300mm	PFS300	PFS300L
450 x 450mm	PFS450	PFS450L
550 x 550mm	PFS550	PFS550L
600 x 600mm	PFS600	PFS600L

### Beaded Frame

Dimensions	Standard	Lockable
200 x 200mm	BFS200	BFS200L
300 x 300mm	BFS300	BFS300L
450 x 450mm	BFS450	BFS450L
550 x 550mm	BFS550	BFS550L
600 x 600mm	BFS600	BFS600L

## The Standard Steel Access Panels

The range of non-fire rated steel access panels provides access into all types of wall and ceiling construction voids. The panels consist of 1.0mm powder coated zintec steel with a slim profile, producing a lightweight, robust panel where access to building services is required.

The metal frame holds a flush metal door through a simple concealed hinge and is held closed with a budget catch. Secure key lockable versions are available. As standard, all doors are powder coated in white RAL 9010 with 20% gloss. Panels can be over painted on site. Other colours are available to order.

All panels can be manufactured with a picture frame (PF) or a beaded frame (BF).

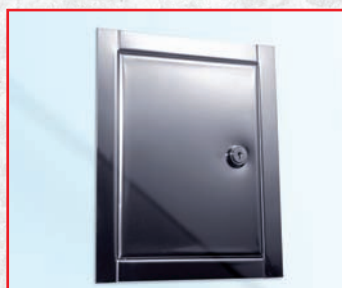

The panels are also available in Chrome (quote using product code and postfix ref C) and Stainless Steel for use in corrosive areas (quote using product code and postfix ref SS).





## The Fire Rated Steel Access Panels



Picture Frame

Available in the following standard sizes

Dimensions	Standard	Lockable
200 x 200mm	PFFD200	PFFD200L
300 x 300mm	PFFD300	PFFD300L
450 x 450mm	PFFD450	PFFD450L
550 x 550mm	PFFD550	PFFD550L
600 x 600mm	PFFD600	PFFD600L



Our range of high quality, precision welded one-hour fire rated steel access panels tested to B.S.476: Part 22:1987 provide access into all types of wall and ceiling construction voids.

The panels consist of 1.0mm powder coated zintec steel with a slim profile, producing a lightweight, robust panel where access to building services is required.

The metal frame holds a flush metal door through simple concealed hinges and is held closed with a budget lock. Secure key lockable versions available.

As standard all doors are powder coated in white RAL 9010 with 20% gloss. Black and other colours are available to order (panels can be over painted on site if required).

All panels are manufactured with a picture frame (PF) or a beaded frame (BF).

With options for Part "L" insulated and air test compliancy.

The panels are also available in Chrome (quote using product code and postfix C) and Stainless Steel for use in corrosive areas (quote using product code and postfix SS).

**Non-standard bespoke sizes manufactured to order.**



Beaded Frame

Available in the following standard sizes

Dimensions	Standard	Lockable
200 x 200mm	BFFD200	BFFD200L
300 x 300mm	BFFD300	BFFD300L
450 x 450mm	BFFD450	BFFD450L
550 x 550mm	BFFD550	BFFD550L
600 x 600mm	BFFD600	BFFD600L



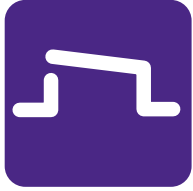

# Roof Hatches

## RHS (Galvanized Roof Hatch)

A roof hatch that includes several innovative features. Access Building Products roof hatches maintain heavy gauge stiffeners for added support and stability. The exterior handle has a push-button lock release located on the front side of the cover, shielded from environmental elements to prevent water accumulation and leakage. All gasketing has wider and more durable gasketing to maximize the door/curb seal and ensure a watertight closure. All edges have been rounded for improved safety. Advanced assembly method allows for reduced welding blemishes. Roof hatches are finished with EPA approved electrostatic paint.

Door Size (mm)	Weight (kg)
610 × 914	61.2
762 × 914	70.3
762 × 1372	102.1
762 × 2438	152.7

## RHA (Aluminium Roof Hatch)

A roof hatch that includes several innovative features. Access Building Products roof hatches now maintain increased gauge of aluminum for greater durability and strength. The exterior handle has a push-button lock release located on the front side of the cover, shielded from environmental elements to prevent water accumulation and leakage. All gasketing is wider and more durable to maximize the door/curb seal and ensure a watertight closure. All edges have been rounded for improved safety. Advanced assembly method allows for reduced welding blemishes. Roof hatches are finished with EPA approved electrostatic paint.

Door Size (mm)	Weight (kg)
610 × 914	31.8
762 × 914	38.6
762 × 1372	61.7
762 × 2438	111.1

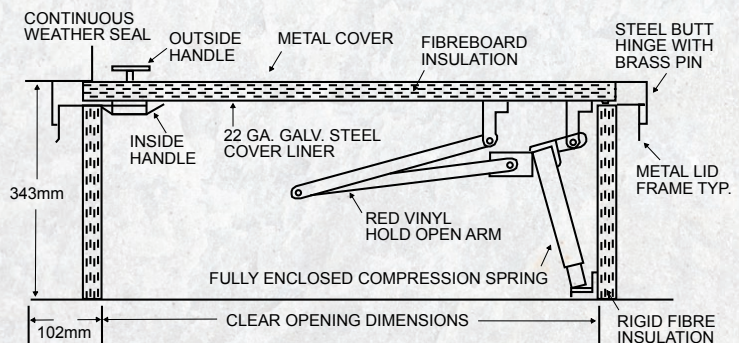





# Tubular Skylights

Daylight for dark spaces!

- Available in 254mm and 356mm diameter
- Three leak-proof flashing options
- Saves energy while bringing in soft, natural light



Tube Kit	Tube Diameter (mm)	Flashing	Roof Type	Product Weight (kg)
SK10SFT	254mm	Plastic	Slate/Flat Tile	7.26
SK10RT	254mm	Formable	Rolled Tile	7.26
SK10FR	254mm	Steel	Flat Roof	7.26
SK14SFT	356mm	Plastic	Slate/Flat Tile	10.43
SK14RT	356mm	Formable	Rolled Tile	10.43
SK14FR	356mm	Steel	Flat Roof	10.43

Extension Tube	Tube Diameter (mm)	Length	Product Weight (kg)
SK10TUBEA	254mm	0.5	1.2
SK10TUBEB	254mm	1.2	1.8
SK14TUBEA	356mm	0.5	1.3
SK14TUBEB	356mm	1.2	1.9

Kit includes:

Solar Lens Dome (254mm shown)

One-piece Seamless Flashing (Plastic shown)

0.6m Adjustable Reflective Tube jointed for easy fit

0.6m Adjustable Reflective Tube jointed for easy fit

Ceiling Trim Ring with flip tabs

Toughened Glass Diffuser

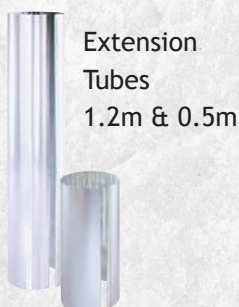
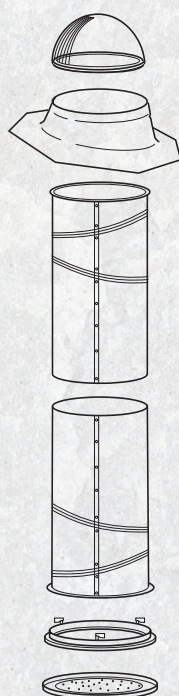

Extension Tubes  
1.2m & 0.5m

- Patented Solar Lens Dome increases light through tube
- A Universal Electric Light Kit (SKL) is also available





roof domes

## Roof Domes



Ultra Dome



Trade Dome



Reflex Dome

## Ultra Dome

The Ultra Dome was designed for maximum security. It is therefore ideal for schools, hospitals, sports & leisure centres and offices. Its aluminium-reinforced uPVC frame conceals all the fixings, acting as a deterrent, while a unique lock-bolt system fixes the glazing to the base. This can only be opened with a specially designed slide key.

## Trade Dome

The Trade Dome is a particularly cost-effective rooflight. It is supplied with a pre-drilled glazing unit that allows the installer to screw fix the glazing to the kerb, making installation even quicker and easier. Once installed, security caps encase the fixings for additional security.

## Reflex Dome

The Reflex Dome is the glazing-only option. It was specifically developed with wide 80mm and 100mm flanged polycarbonate glazing units for the refurbishment sector. This fits mechanically over existing kerbs or upstands of varying dimensions. Opening and ventilation options in the Access Building Products range include manual and powered hinges and automatic openers to help with smoke clearance. The latter open up to 90° to give maximum possible ventilation in the event of a fire. In addition to the standard domes, Access domes are also available in a pyramid profile that is safer in areas where there is a risk of people walking on the roof-light.

Thermal Properties (W/m <sup>2</sup> K)		Roof opening / rooflight size (mm)	ULTRA triple skin	Trickle vent	AHC Trickle vent*	Manual linear drive	Powered linear drive	Access hatch	Smoke dome	TRADE# triple skin	Trickle vent	AHC Trickle vent*	Manual linear drive	Powered linear drive	Access hatch	Smoke dome	REFLEX+ single, double or triple skin
U value Ultra	Triple skin																
U value Trade																	
Fragility	Class B non-fragile to ACR[M]001:2005 and non-fragile to BS EN 1873																
Options																	
Kerb	GRP only available on trade - circular dome																
Profile	Curved dome, circular dome, trapezoidal or pyramid profile																
Tint	Clear, bronze or opal tint or textured glazing option																
Ventilation	Trickle vent Automatic humidity-controlled trickle vent Manual or powered linear drive Access hatch Smoke clearance dome (SV30/SV90 automatic opening domes)																
		450 x 450															
		600 x 600	▲	▲	✓	✓	✓			▲	▲	✓	✓	✓	✓		▲
		600 x 900	▲	▲	✓	✓	✓		★	▲	▲	✓	✓	✓	✓	★	▲
		600 x 1500	▲	▲	✓	✓	✓		★	▲	▲	✓	✓	✓	✓	★	▲
		750 x 750	▲	▲	✓	✓	✓		✓	▲	▲	✓	✓	✓	✓	✓	▲
		750 x 900	▲	▲	✓	✓	✓		✓	▲	▲	✓	✓	✓	✓	✓	▲
		900 x 900	▲	▲	✓	✓	✓		✓	▲	▲	✓	✓	✓	✓	✓	▲
		900 x 1800	▲		✓	✓	✓		✓	▲	▲	✓	✓	✓	✓	✓	★
		1050 x 1050	▲	▲	✓	✓	✓		✓	▲	▲	✓	✓	✓	✓	✓	▲
		1050 x 1500	▲	▲	✓	✓	✓		✓	▲	▲	✓	✓	✓	✓	✓	▲
		1200 x 600	▲	▲	✓	✓	✓		★	▲	▲	✓	✓	✓	✓	★	▲
		1200 x 900	▲	▲	✓	✓	✓		✓	▲	▲	✓	✓	✓	✓	✓	▲
		1200 x 1200	▲	▲	✓	✓	✓		✓	▲	▲	✓	✓	✓	✓	✓	▲
		1200 x 1500	▲	▲	✓	✓	✓		★	▲	▲	✓	✓	✓	✓	★	▲
		1200 x 1800	▲		✓	✓	✓		★	▲	▲	✓	✓	✓	✓	★	▲
		1200 x 2400	▲		✓	✓			✓	▲	▲	✓	✓			★	▲
		1350 x 1350	▲	▲	✓	✓			✓	▲	▲	✓	✓			✓	▲
		1500 x 1500	▲	▲	✓	✓			✓	▲	▲	✓	✓			✓	▲
		1800 x 1800	▲		✓	✓			✓	▲	▲	✓	✓			★	▲

▲ CURVED PROFILE ★ Single-skin option only available in clear # Circular dome available with/without GRP kerb

▲ PYRAMID PROFILE ★ Available as SV30 only \* Automatic Humidity-Controlled Trickle vent

Bespoke sizes available, subject to minimum order





solar entry light



## Solar Entry Light

The Access Solar Entry Light is a great addition to any entryway. It provides both security and light through the power of the sun. The Solar Entry Light's benefits include helping preserve the Earth's valuable resources by relying purely on the sun for its power.

### Features

- Four super bright LED lights
- Rechargeable batteries enable up to 12 hours of continuous light
- Solar panel extends up to 4500mm for maximum sunlight
- Easy to install
- Turns on automatically at night
- Weather resistant
- One-year warranty

Product Code	Colour	Dimensions (mm)	Weight
SEL	White	838L x 228W x 76H	3Kg



Door Frame



Easy Fit



Shed

Above are photos that demonstrate creative and innovative ways that the Solar Entry Light can be used.



Access Building Products Limited is a privately owned company producing and supplying Loft Access Traps, Access Panels and Associated Products to the Private and Public Sectors of the Building Industry, through Distributors and Builder's Merchants.

For up to date information please refer to our website:

[www.accessbuildingproducts.co.uk](http://www.accessbuildingproducts.co.uk)



Access Building Products Ltd Dale View Old Hall Farm Gatenby North Yorkshire DL7 9PG

Tel: 01677 426060 Fax: 01677 426070

[info@accessbuildingproducts.co.uk](mailto:info@accessbuildingproducts.co.uk) [www.accessbuildingproducts.co.uk](http://www.accessbuildingproducts.co.uk)