

TS20A, 2"

Anodized Aluminum, Mechanical

- Only two moving parts
- No metal to metal contact in chamber or bearings
- Patented 'Wave Form' oval gear design
- Low differential pressure for maximum flow

Specifications

- **Nominal Capacity with standard LV rotors:**

To 1500 SSU visc. :	150 GPM	} NTEP 5:1 turn-down OIML 10:1 turn-down Industrial to 30:1 turn-down
To 300 cP viscosity :	570 lpm	
To 300 cP viscosity :	34 m³/h	
- **Pressure Rating** : 150 PSI at 100°F = 10 BAR at 40°C
with 3:1 Safety Factor
- **Temperature Rating** : -40°F to +180°F = -40°C to +80°C
- **Viscosity**
 - LV & HT rotors: 100% capacity to 1,500 SSU (300 cP).
 - HV rotors : 100% capacity to 5,000 SSU (1000 cP),
reduced capacity to 1,500,000 SSU (350,000 cP).
- **2" Connections** Bolted companion flanges with NPT or BSP port.
Optional : Bolted welding flanges, anodized aluminum
Bolted welding flanges, carbon steel
Bolted 150# RF ANSI adaptors, carbon steel
- **Materials 100% non-ferrous**
 - Case : Anodized aluminum
 - Gears : PPS with carbon bearings, Teflon™ bearings opt.
 - Posts : HC303SS
 - Seals : Viton™ standard, Teflon™ optional.
 - Flanges : Anodized aluminum standard, carbon steel opt.
- **Pulser** None
Optional : 10:1 dry reed on mechanical register
100:1 solid state on mechanical register.
- **Pulse Resolution**

	10:1	100:1
1/10 gallon register	10 PPG	100 PPG
Whole gallon register	1 PPG	10 PPG
Liter register	1 PPL	10 PPL
Dekaliter register	0.1 PPL	1 PPL

FPP METERS Lower Cost of Ownership!

TS20AV06AT
Standard strainer/air eliminator
and mechanical register



TS20AV13ATCBMxAH4

High capacity* strainer/air eliminator,
mechanical preset/linkage/valve & register
* Required on diesel fuel tank trucks subject to 'split compartment' testing,
if the flow rate exceeds 70 GPM (265 lpm).

Meter Performance

- **Linearity** Over 5:1 turn-down from max. capacity: ±0.175%
Over 10:1 turn-down from max. capacity: ±0.25%
Over 30:1 turn-down from max. capacity: ±0.5%
- **Repeatability** 0.05% or better under constant conditions
- **Approvals** Custody Transfer approvals are liquid specific.
W&M approval in the US, Canada*, EU & Australia.
* Canada = 380 lpm, recertification to 570 lpm pending.

- **Flow Meter** CE mark.

Registration & Accessories

- **Registration options:**
 - Register : #7887 standard (5 digit reset & 8 digit totalizer)
#7886 optional (6 digit reset & 8 digit totalizer).
 - Calibration : 1/10 gallon standard,
whole gallon, whole liter or dekaliter optional.
 - Preset Counter: #7889 2-stage shut-off,
optional micro switch kit in X-Prf enclosure.
 - Ticket Printer : #7888 Zero Start standard,
Accumulative optional
- **Accessories**
 - Inlet strainer for flow meter protection
 - High capacity strainer for high speed diesel truck service
 - Air eliminator mounted on strainer
 - Backpressure valve for enhanced air elimination on trucks
 - Air Check Valve on flow meter outlet side
 - Mechanical preset valve

TS20A V



ISO 9001:2000 Certified

Part No.

The Part No. extends past Pos. 10 only if non-standard selections are made (rotors, pulser, seals, high capacity strainer or strainer basket mesh size).

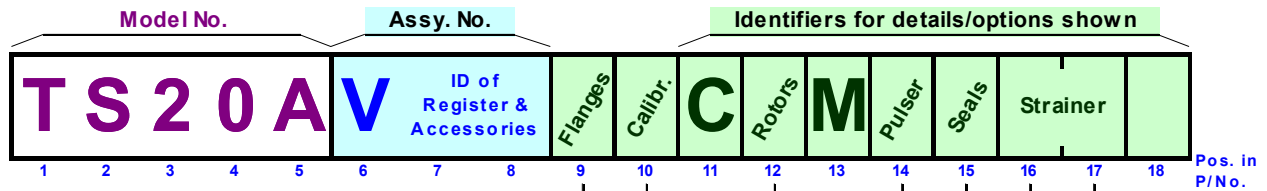

Companion flanges

- A** = 2" NPT port
- B** = 2" BSP port
- C** = 2" 150# RF ANSI
- F** = 2" alum slip-weld
- H** = 2" steel slip-weld

Calibration

- T** = 1/10 gallon
- G** = 1/1 gallon
- L** = liter
- D** = dekaliter

Rotors & Bearings

- B** = LV, PPS/carbon
- L** = HT, PPS/carbon
- I** = HV, PPS/carbon
- C** = LV, PPS/Teflon
- M** = HT, PPS/Teflon
- J** = HV, PPS/Teflon

Pulser

- X** = none
- D** = 10:1
- S** = 100:1

Seals

- A** = Viton
- B** = Teflon

Strainer Basket

- 4** = 40 mesh (LV & HT)
- 2** = 20 mesh (HV)
- 0** = 100 mesh

Strainer

- S** = Right-angle strainer
- H** = High Capacity Strainer

Highlighted = Standard

TS20AV17AT

All dimensions in inches (1" = 25.4 mm)

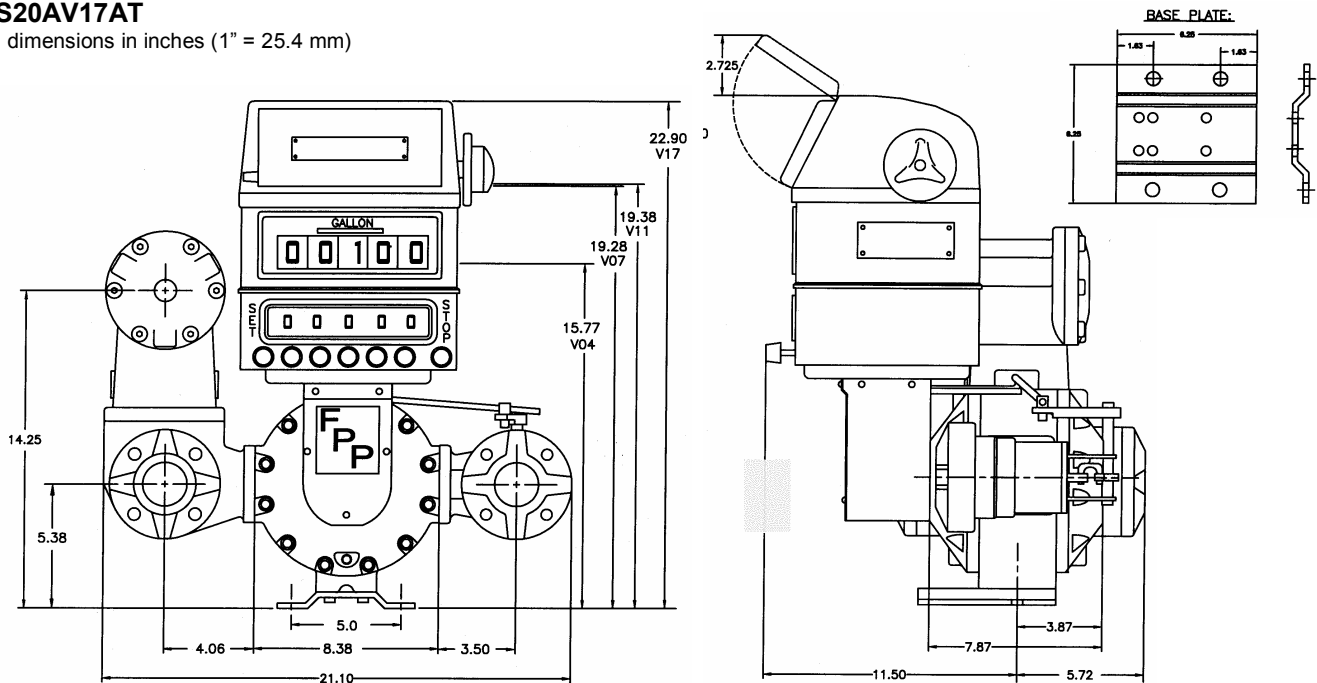

Distributed by: