

# DUC

- Prevents bridging of product at the hopper outlet
- Smooth flow of material
- Maximum discharge efficiency
- Cast housing, explosion proof construction
- Compact forms
- Easy clean features
- No separation of premixed product



*Base unit with optional hopper*

*Base unit*

## **DUC 200 Discharge unit**

The DMN-WESTINGHOUSE DUC 200 discharge unit is specially designed to prevent bridging of product at the hopper outlet (up to 5 m<sup>3</sup>).

A rotating paddle inside the hopper cone keeps the product in motion. When mixed products are used, the rotating blade avoids product separation at the hopper outlet.

The DUC 200 discharge unit guarantees a smooth flow of product and maximizes the filling efficiency of the component installed below the unit (e.g. a rotary valve).

## **Product information**

The housing is made of cast stainless steel. The complete construction is explosion proof. Flanges and all product contact surfaces are in stainless steel.

The discharge unit is equipped with specially designed seals to withstand internal pressures up to 1 bar g at 100 °C.

The DUC 200 discharge unit is available in one standard size with an inlet of Ø 200 mm.

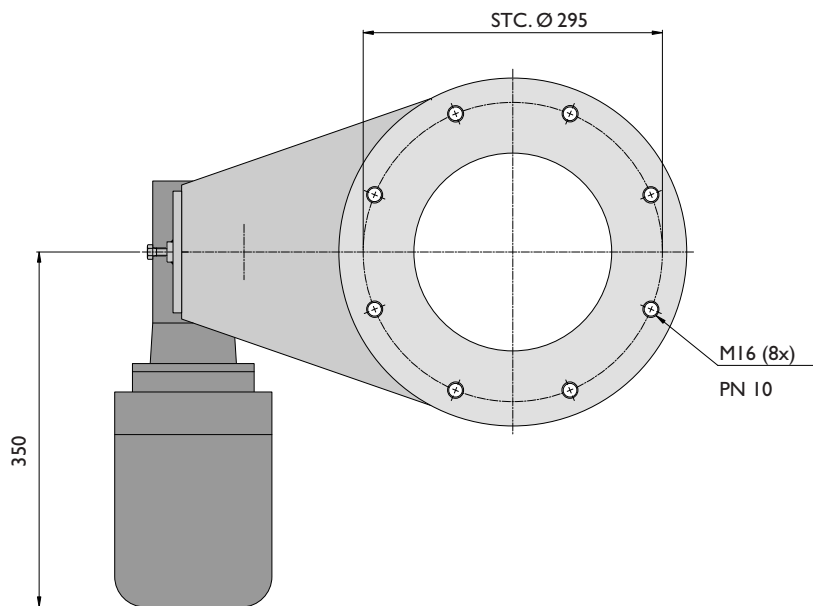
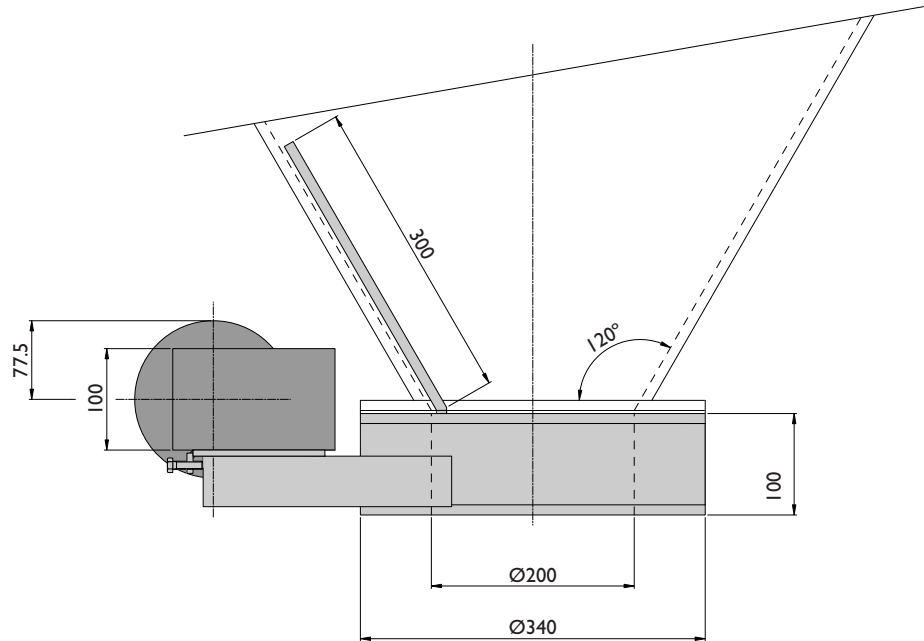

DMN-WESTINGHOUSE have been designing and manufacturing rotary valves, diverter valves and other related components for the bulk solids handling industry for more than 30 years. Offering tailor made solutions for chemical, food, plastics and pharmaceutical industries, DMN-WESTINGHOUSE products are distributed worldwide.

Besides an extensive range of standard components, we supply USDA accredited sanitary versions and ATEX approved explosion-proof models.

An extensive network of subsidiaries, distributors and representatives ensures a high level of service and support all over the world.

© DMN - HOLLAND - 04/05

**Head Office:**  
**DMN Machinefabriek**  
**Noordwykerhout BV**  
 PO Box 6, NL - 2210 AA  
 Noordwykerhout, Holland  
 Tel. +31 252 361 800  
 Fax +31 252 375 972/934  
 dmn@dmn-nwh.nl

**DMN Incorporated**  
 3895 South Perkins Road, Suite 8  
 Memphis, TN 38118, USA  
 Tel. +1 901 360 1537  
 Fax +1 901 360 0348  
 dmnfo@dmn-inc.com

**DMN UK Ltd**  
 Unit 1&2, Harris Road,  
 Porte Marsh Industrial Estate  
 Calne, Wiltshire, SN11 9PT, UK  
 Tel. +44 1249 818 400  
 Fax +44 1249 818 410  
 dmn@dmnuk.com

**DMN Schüttguttechnik GmbH**  
 Rütgersstrasse 8  
 D-21244 Buchholz i.d. Ndh, Germany  
 Tel. +49 4181 931 40  
 Fax +49 4181 931 490  
 dmn@dmn-schuettingtechnik.de

**DMN France SAS**  
 65, rue Charles de Gaulle  
 91330 Yerres, France  
 Tel: +33 1 69 49 85 70  
 Fax: +33 1 69 49 85 79  
 dmnfrance@wanadoo.fr



[www.dmn.info](http://www.dmn.info)