

MIXO inserts for multipole connectors for fibre optic and coaxial contacts.

LWL contacts according to CECC 78 001-801 (former DIN 41 626 part 3) for 1 / 2.2 mm POF (Polymer Optical Fibre) and 1.5 / 2.3 MOST (Media Oriented System Transport) optical fibre.

Coaxial contacts (DIN 41 626) 50 ohm and 75 ohm.

The new MIXO insert allows the use of contacts for fibre optic and contacts for coaxial cables.

To protect against EMC-problems (electromagnetic interference) and for the realization of galvanic separations on BUS applications of PROFINET/Ethernet fields, solutions with optical fibres are recommended.

Fibre optic connectors are many industrial applications, particularly, modern railway vehicles, converters, wind energy, naval equipments and robots.

The new connectors can be used in applications from -40 °C up to +85°C even in case of frequent temperature variability.

The inserts can be mounted in CX .. TF/TM frames and in the relative enclosures for industrial applications to achieve IP65/66/68/69K degree of protection (according to the required versions). The realization of mixed connectors electrical/optical are also possible.



These new inserts keep the same features of our usual MIXO series that has an easy module fixing system.

On request we may provide also POF (Ø 2.2 mm external diameter, Ø 1.0 mm fibre) and MOST-POF (Ø 2,3 mm external diameter, Ø 1.0 mm fibre) contacts for use at higher temperatures and high temperature variations.

For further optical fibre versions, please contact us.

To assemble the contacts it is needed to cut and strip the cable, to crimp the contact (even gluing is possible) and then to grind the fibre tip protruding from the contact.

In the same MIXO insert it is also possible to use coaxial connectors for 50 ohm (RG 316/U, RG 174/U and RG 188 A/U) and 75 ohm (RG 179 B/U, RG 187 A/U and TZC 75 101) cables.

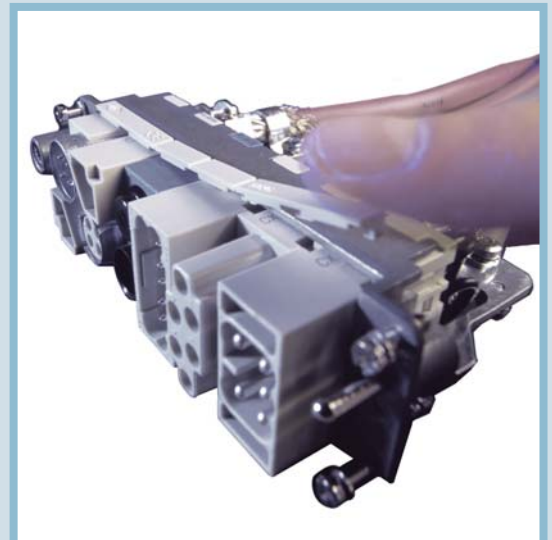

To remove both male and female contacts please use the correct extraction tool.

CECC 78 001-801 contacts
(DIN 41 626, part 3)



Mixo insert
for 4 optical fibre contacts

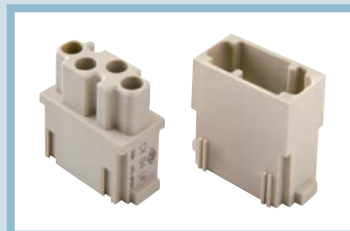

DIN 41 626 contacts



Characteristics

- 1 electric contacts in silver-plated or gold-plated brass with connections to the conductors via crimping.
- 2 pneumatic contacts in plastic with insertion tube connection.
- 3 modular inserts of identical size with insertion system for forming the complete module and frame lock tab.
- 4 inserts in self-extinguishing thermosplastic material, reinforced with glass fibre, UL 94-V0 approved, with a working temperature range of -40 °C to +125 °C.
- 5 inserts in conformance with the requirements of the EN 61984 standard and certified and marked with the UL, CSA, CCC, GL marks.
- 6 inserts with asymmetric guide rails to prevent incorrect coupling.
- 7 position of contacts identified with numbers or codes on both sides of every insert.
- 8 male/female module carrier frames with mandatory housings and polarity, in die-cast zinc alloy.
- 9 module lock tab, may be divided according to the number of modules used; guarantees a perfect stability of the modules during wiring and coupling/uncoupling of the connectors.
- 10 asymmetric earth contacts (two for frame) with wide contact surface prevent incorrect coupling; when two or more identical connectors of the MIXO series are used, coded pins prevent incorrect coupling (see Catalogue CN.07).
- 11 captive frame fastening screws, with flexible spring washer.
- 12 dummy module for unused frame slots.

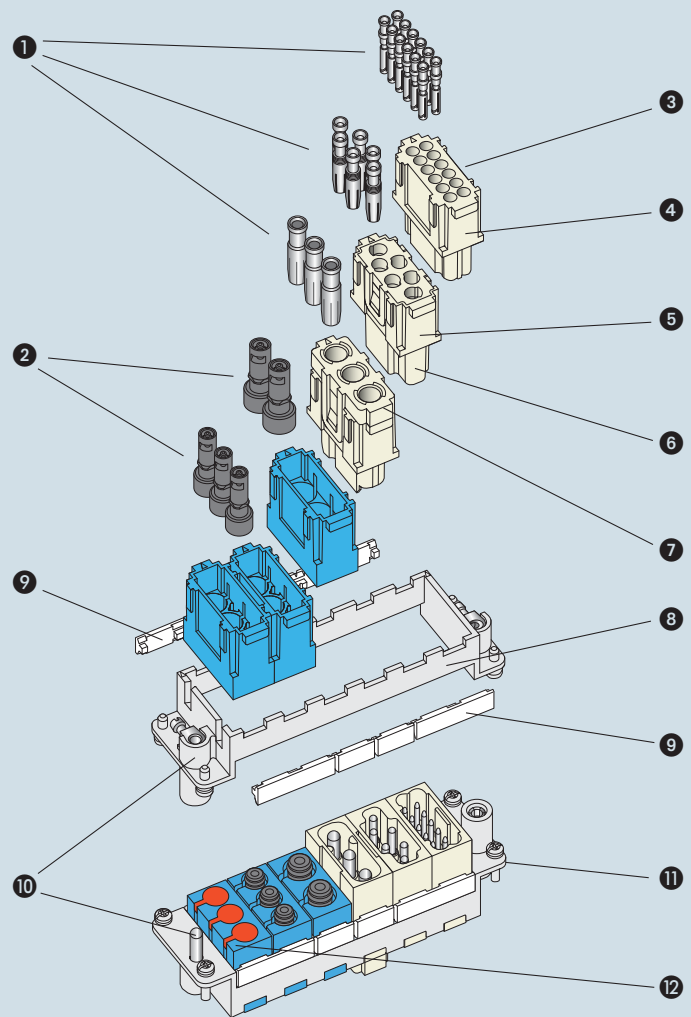

inserts	contact type	signal type	connectors and tubes connections	rated current A	rated voltage V	No. of frame slots
CX 01 YF/M	main	electric	crimp	200	1000	2
CX 02 GF/M	main	electric	crimp	100	1000	2
CX 02 4AF/M	main	electric	axial screw	40	1000	1
CX 03 4F/M	main	electric	crimp	40	400/690	1
CX 05 SF/M	main	electric	spring	16	400	1
CX 06 CF/M	main	electric	crimp	16	500	1
CX 08 CF/M	main	electric	crimp	16	400	1
CX 20 CF/M	main	electric	crimp	16	500	2
CX 12 DF/M	main / auxiliary	electric	crimp	10	250	1
CX 17 DF/M	main / auxiliary	electric	crimp	10	160	1
CX 02 HF/M	main	electric	crimp	16	2900/5000	2
CX 02 BF/M	multiaxial connectors	see CX 04 B	---	---	---	2
CX 01 BF/M	main / auxiliary + shield	electric	crimp	10	50	---
CX 04 BF/M	main / auxiliary + shield	electric	crimp	10	50	---
CX 03 P	pneumatic Ø 1.6 - 3.0 - 4.0 mm	gas / liquid **	insertion	---	---	1
CX 02 P	pneumatic Ø 6.0 mm	gas / liquid **	insertion	---	---	1
CX FM	none (dummy module)	---	---	---	---	1
CX 01 JF/M	RJ45 + auxiliary	electric	crimp	---	---	2
CX 02 JF/M	RJ45 + auxiliary	electric	crimp	---	---	3
CX 01 UF/M	USB	electric	---	---	---	1
CX 04 LF/M	POF / MOST / coaxial DIN 41626	optic / electric	crimp	---	---	1

** **Warning:** For obvious reasons of safety, the VDE standard does not permit electric contacts to be present within the same connector group together with contacts for the transmission of liquids. In addition, the use of pneumatic air contacts requires an appropriate filtering and dehydration system to prevent dangerous condensation. Contacts may be used for pressure values of up to a maximum of 8 bar/116 psi.

We remind always to check the correct air flow and/or the electrical/optical conduction in the actual working condition on mated and coupled connectors.

the modular inserts must be installed in suitable frames which are then mounted in traditional housings or COB panel support

frames for modular units page: 151**

- to crimp contacts CX PLF / PLM and CX MLF / MLM please use tool CLPZ R
- max external diameter: 2.2 mm (POF)
2.3 mm (MOST)
- polymer fibre diameter: 1.0 mm (POF)
1/1.5 mm (MOST)
- attenuation: < 2.5 dB
- temperature range: -40 °C + +85 °C

** refer to catalogue page CN.07

modular units,
crimp connections

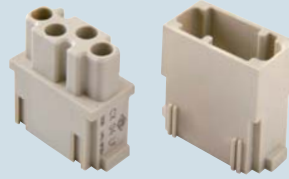

NEW

POF / MOST crimp contacts



NEW

description	part No.	part No.
without contacts (to be ordered separately) - female inserts for female contacts - male inserts for male contacts	CX 04 LF CX 04 LM	
female contacts POF * 1.0 mm male contacts POF * 1.0 mm		CX PLF CX PLM
female contacts MOST *** 1/1.5 mm male contacts MOST *** 1/1.5 mm		CX MLF CX MLM

* POF = POLYMER OPTICAL FIBRE
*** MOST = MEDIA ORIENTED SYSTEM TRANSPORT

We recommend to use CLASS enclosures with two levers or V-Type enclosures (with one or two levers) that provides a higher coupling depth due to the higher locking force they produce. We further suggest the use of code pins CRF CX / CRM CX.

dimensions in mm

CX 04 LF / LM

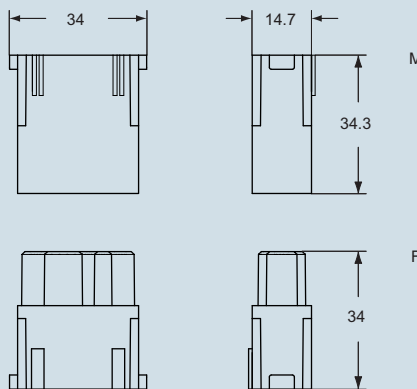

contacts side (front view)

side with reference arrow ▲

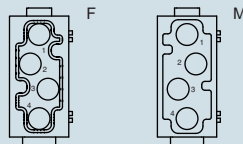

- 1 frame slot

dimensions in mm

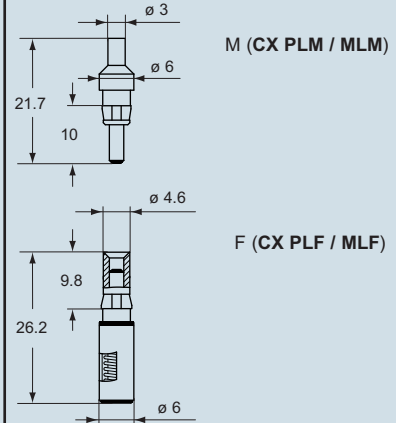

cable stripping for fibre optic

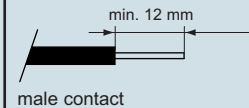

male contact

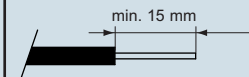

female contact

dimensions shown are not binding
and may be changed without notice

for contacts series:	page
CX PLF/PLM	3
CX MLF/MLM	3

manual crimping tool



polishing disc - polish paper - removal tool
jacket stripper and fibre stripper
cable cutter



description	part No.	part No.
crimping tool for POF CX PL and MOST CX ML contacts RENNSTEIG model **	CLPZ R	
polishing disc (RATIOPLAST 910 PS 0SC 00 001) - for POF * and MOST *** contacts		CLDL
polish paper: - grain size 1000 (RATIOPLAST 910 PB 001 00 001) - grain size 4000 (RATIOPLAST 910 PB 001 40 250)		CLC1 CLC4
removal tool for the extraction of contacts from the CX L inserts		CLES
- jacket stripper (RATIOPLAST 910 AZ 001 00 PA1) for POF * and MOST *** fibre optic with PA jacket - fibre stripper (RATIOPLAST 910 AB 001 00 001) for POF * fibre optic		CLSG CLSP
cable cutter (RATIOPLAST 910 SW 001 00 001) for Ø 2.3 mm max., for POF * and MOST *** fibre optic		CLTE

** on request tool **CLPZ** RATIOPLAST 910 CZ 001 00 005 for contacts POF * crimping on the back

* **POF** = POLYMER OPTICAL FIBRE
*** **MOST** = MEDIA ORIENTED SYSTEM TRANSPORT

Note:
as alternative to crimping please use glue UHU PLUS ENDFEST 300 (BICOMPONENT), part No. **CL GL**

- 1) mix the two components on a sheet (just a drop/each)
- 2) the stripped ca. 5 mm POF * (that means the inner fibre) has to be dipped in the glue (just 5 mm)
- 3) the POF * has to be pushed now in the contact/ferrule
- 4) min. one night to hard/dry the glue
- 5) finally the POF * has to be polished (polishing disc)

CLPZ R



CLDL



CLC1 /CLC4

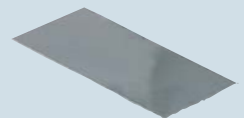

CLES



CLSG



CLSP



CLTE



General specifications

Strip the fibre about 12 mm for male contact and about 15 mm for female contact (see Figures 1 and 2).

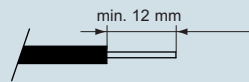

Fig. 1 - Example of cable stripping for male crimp contact

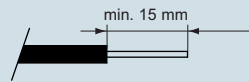

Fig. 2 - Example of cable stripping for female crimp contact

Crimping instructions

- The data sheet for crimping tool **CLPZ R** explains how the crimping tool works and how to adjust the crimping depth and locator for the contacts to be crimped. Position the turret on 3, push and turn of 90° the knob of turret. Adjust the crimping depth on 2 (unscrew the allen screw, after adjusting reflex the screw). For the female contact: unscrew the back of the contact, pull out the internal central part; on Figure 3 is indicated the crimping area (front part of contact). For male contact: crimp the front part of contact.
- Push the stripped fiber as far as possible into the contact sleeve so that it protrudes approx. 1 mm from the tip of the contact.



Back of contact



Contact/fibre crimping area

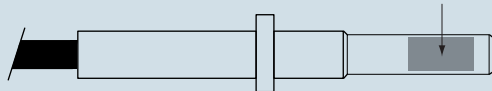

Fig. 3 - Female contact/fibre crimping area



Fig. 4 - Male contact/fibre crimping area

- Insert the contact together with the fibre optic cable as far as possible into the crimping opening of the crimping tool (**CLPZ R**, see Figure 5) while applying gentle pressure to the fibre optic cable and connector, close the tool until you hear it disengages.

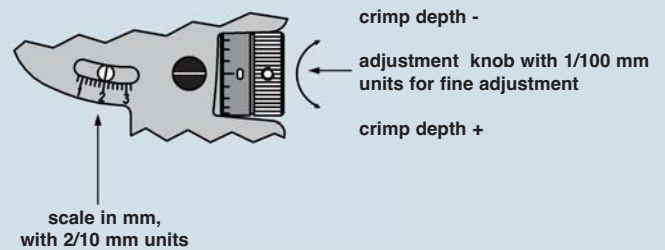
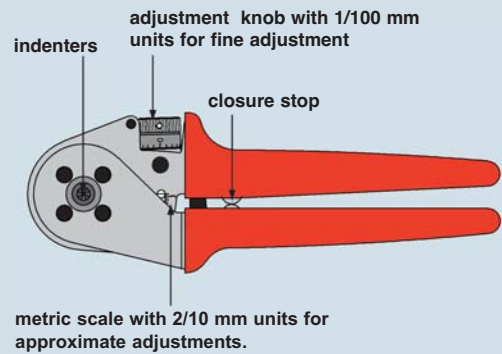

Fig. 5 - Manual crimping tool

Finishing the front surface

- Insert the contact into the polishing disc (**CLDL**) as shown in Figure 6.
 - Work on a smooth surface (such as a sheet of glass), use grade 1000 polishing paper to grind off the protruding fibre and polish it with grade 4000 polishing paper.
 - Wipe away any residue remaining after grinding.
- The best optical attenuation values are achieved when a wet grinding method is used.

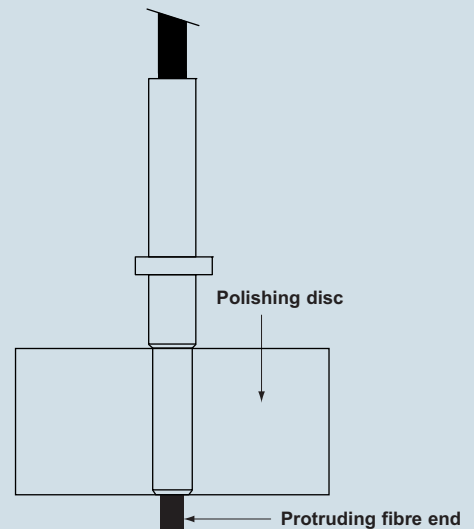

Fig. 6 - Polishing Disc with Guide for Connector Sleeve

Final mounting instructions

- Screw the back female part contact.
- Put inside the insert CX 04 LF/ CX 04 LM.

the modular inserts must be installed in suitable frames which are then mounted in traditional housings or COB panel support

frames for modular units page: 151*

- to crimp contacts CX 50 M/F, CX 75 M/F use tool COPZ
- in accordance with standard DIN 41625 part 2
- finishing: contact surfaces and body gold plated, back end and ferrule nickel plated
- frequency range: ≤ 2 GHz
- reflection coefficient: ≤ 0,1
- rated voltage: 50V
- rated current: 1.5A

* refer to catalogue page CN.07

modular units,
crimp / solder connections

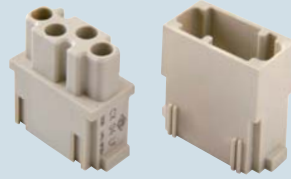

NEW

crimp / solder coaxial contacts



NEW

description	part No.	part No.
without contacts (to be ordered separately) - female inserts for female contacts - male inserts for male contacts	CX 04 LF CX 04 LM	
female coaxial contacts 50Ω male coaxial contacts 50Ω		CX 50 F CX 50 M
female coaxial contacts 75Ω male coaxial contacts 75Ω		CX 75 F CX 75 M

dimensions in mm

CX 04 LF / LM

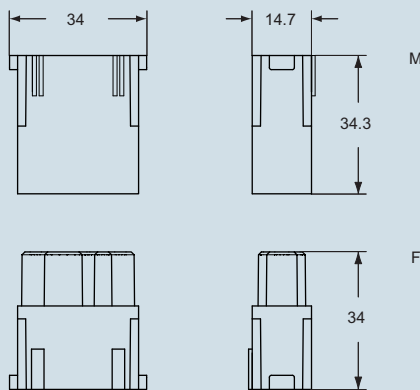

contacts side (front view)

side with reference arrow ▲

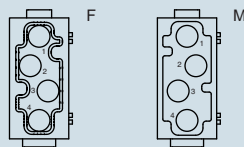

- 1 frame slot

dimensions in mm

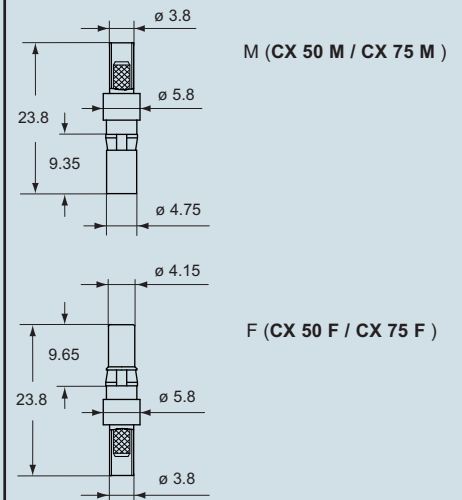

conductor stripping

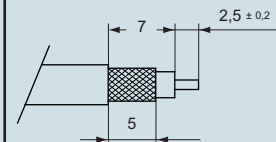

coaxial contacts	for cables	ø external	part No.
50Ω	RG 316/U	2,49 ±0,1	CX 50 F
	RG 174/U	2,79 ±0,127	CX 50 M
	RG 188 A/U	2,79 max	
75Ω	RG 179 B/U	2,54 ±0,127	CX 75 F
	RG 187 A/U	2,79 max	CX 75 M
	TZC 75 101	2,79 max	

dimensions shown are not binding and may be changed without notice

for contacts series:	page
CX 50 F/M	6
CX 75 F/M	6

manual crimping tool



removal tool



description	part No.	part No.
crimping tool for CX 50 F/M and CX 75 F/M coaxial contacts	COPZ	
removal tool for the extraction of contacts from the CX L inserts		CLES

Crimping instructions

- 1) strip the cable as per drawing (page 6)
- 2) crimp the central contact of coaxial connector with the position 0.7 of crimping tool
- 3) insert the central contact in the coaxial connector, put the braid shield around the back cylinder of contact
- 4) insert the brass back end on the braid shield
- 5) crimp the ferrule with position 3.25 of crimping tool

We recommend the use of code pins CRF CX / CRM CX.

As alternative to crimping, it is possible to solder the central contact.

CX 50 F/M and CX 75 F/M coaxial contacts

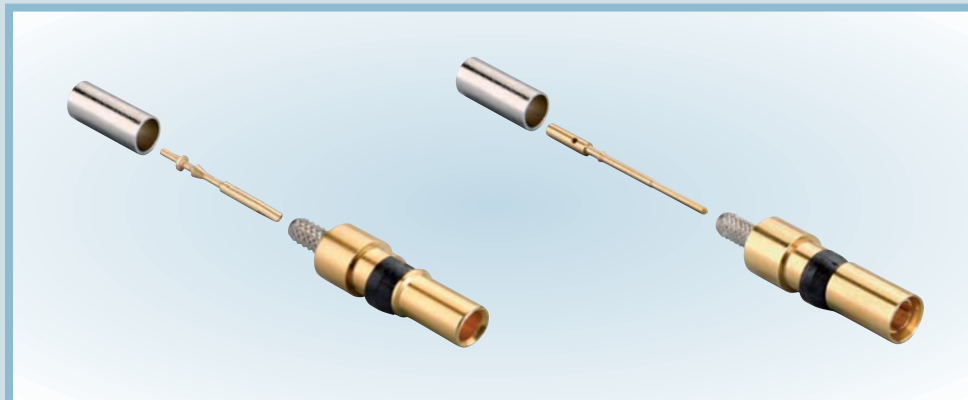

- die-cast zinc alloy frames
- with VDE ground contacts
- possibility of mounting female and male modular units on the same frame
- frames supplied with lock-in tab to attach units
- polarisation on frames
- code pins CR..CX

Warning

the module support frames are marked:

- with upper-case letters **A-B, A-C, A-D** and **A-F** (for use in hoods)
- with lower-case letters **a-b, a-c, a-d** and **a-f** (for use in housings)

Positioning the modules in the frames according to the respective letters is ensuring the specular assembly of modules, for which the hood will be coupled correctly to the housing.

frames for modular units



frames for modular units with lock-in tabs

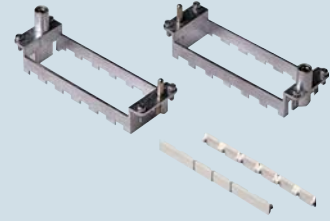

description	part No.	part No.	part No.
for CZ enclosures, size 49.16	CX 01 T		
frames for modular units (module lock-in tabs included) - for 2 modular units - for 3 modular units - for 4 modular units - for 6 modular units		type for hoods	type for housings
		CX 02 TM	CX 02 TF
		CX 03 TM	CX 03 TF
		CX 04 TM	CX 04 TF
		CX 06 TM	CX 06 TF
lock-in tabs for modular units (6 units) dividable		CX CFM	

polarisation of frames with relative identification letters and couplings

frame for hoods 1) frames for housings 2)

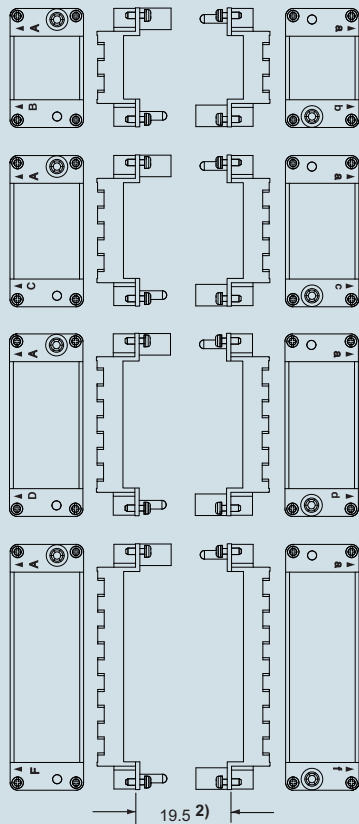

1) the frames can be used either in hoods or housings, for a correct coupling please use both frame types (one with upper-case letters and the other with lower-case letters)

2) distance for electric and fibre optic contacts: max 21 mm
distance for pneumatic contacts: max 20.5 mm

dimensions shown are not binding and may be changed without notice

dimensions in mm

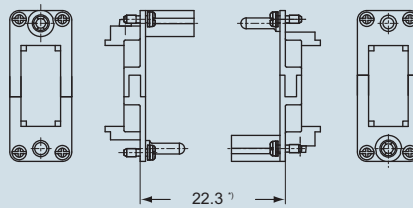
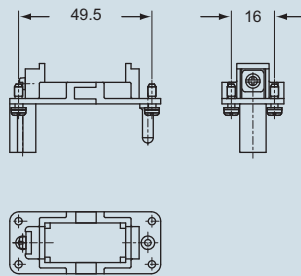

*) distance for electric contacts: max 24 mm
distance for pneumatic contacts: max 23.5 mm

dimensions in mm

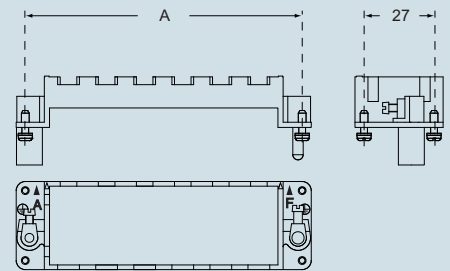

part No.	A (mm) for housings size	
CX 02 TM / TF	44	44.27
CX 03 TM / TF	57	57.27
CX 04 TM / TF	77.5	77.27
CX 06 TM / TF	104	104.27

- large earth terminal for cables from 4-6 mm², AWG 12-10
- small earth terminal for cables from 1-2,5 mm², AWG 18-14

position of modules (contact side view)

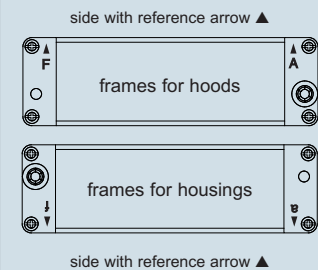

When two or more identical connectors of the MIXO series are used, coded pins are used prevent incorrect coupling (CR...CX series).

CX CFM

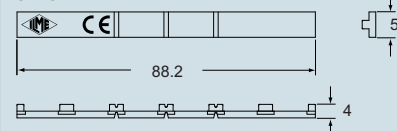

IMPORTANT NOTES

The products in this catalogue cannot guarantee the best functionality on installation, as this depends mainly on their correct "installation into service" which must be performed in compliance with the applicable system safety standards and according to the "rule of the art".

The products shown in this catalogue are deemed to form connections mainly for electrical circuits, therefore they have to be assembled according to the user's best choice for the different applications.

For such choices, as well as for uses of single components and/or for uses with purposes other than those herein declared, I.L.M.E. SpA refuses any liability for the application results and/or for product incorrect use and/or unsuccessful performances.

The connectors must not be connected or disconnected when live or under load.

After wiring the inserts we recommend to verify the protective earth terminals continuity.

The connector inserts operation is guaranteed only if mounted by four screws on a rigid plane (provided by hoods/housings).

I.L.M.E. SpA is not responsible for any different application.

The installer must verify and ensure the correct coupling and operation of the protective earth connection.

For all inserts with screw-type terminals it is important that the correct torque is applied to the screws in order to prevent damage to the conductor, the screw or the terminal.

Crimping tools and contacts should be supplied by the same manufacturer.

The termination of spring-clamp connector inserts is guaranteed only when the specified screwdriver is correctly used for actuating the spring (see indication in the specific catalogue and, where applied, on the insert) and the operating principles are followed.

To prevent incorrect coupling please respect the polarity drawing (contacts side view) when two similar inserts are mounted in double-sized hood or housing. To avoid coupling mismatch we recommend the use of coding pins when two or more similar connectors are mounted close together.

The complete connectors (enclosures and inserts) guarantee the IP degree of protection when coupled and locked with their closing levers. In order to ensure the same degree of protection provided by the connector housings, the cable glands or other accessories used to close cable outlets must also have at least an equivalent IP degree of protection.

In order to prevent stress on the contacts, the connectors must be coupled and uncoupled in the axial direction with respect to the contacts, without bending and pulling the attached conductor bundles or cables.

ILME connectors, inserts and enclosures are generally compatible with similar/equivalent products from other manufacturers, according to the last samples we tested.

The full interchangeability cannot be granted by ILME as we cannot be considered responsible for technical changes made by other manufacturers.

In particular, ILME cannot guarantee the full performances of our IP68 enclosures (Series CG) if coupled with other manufacturers' products.

I.L.M.E. SpA takes no responsibility in verifying whether the components herein contained comply with the specific regulations of fields of application.