



---

**Industry Automation**  
Chain, Robotic, BUS, Sensor Cables

***Industrie Automation***  
*Schlepp-, Roboter-, BUS-, Sensor-Leitungen*



## Preamble

Automation and process control continue to evolve as factories move from “batch” to “lean” manufacturing methods whose prime aim is to reduce the time from customer order to manufacturing and delivery.

This trend strongly affects Original Equipment Manufacturers (OEMs) and Industrial Equipment Manufacturers who use cables as an important part of their own products, including:

- the machine tool industry
- industrial robot manufacturers
- special machinery manufacturers
- industrial LAN designers and builders
- harness assemblers
- cable distributors

Original Equipment Manufacturers and Industrial Equipment

Manufacturers have high expectations of cable manufacturers. They want to eliminate non-value-added process from the production stream. They need flexibility for small series runs and rapid turnover changes in their own production and that of their customers.

They demand complete products that facilitate plug and play, system integration and distributed control. They expect cables to be durable in harsh manufacturing environments, resistant to high electromagnetic interference and safe for both personnel and equipment. In an increasingly integrated world, they expect cables to meet strict international standards and fit the specifications of every industry. Finally, they want a high level of service, from the initial quote and order processing to after-sales maintenance and operational guarantees.

## Vorwort

Automatisierung und Prozesssteuerung entwickeln sich fortlaufend in dem Maße weiter, wie Betriebe von der Batch-Produktion zu „schlanken“ Herstellungsmethoden übergehen, deren Hauptziel es ist, die Zeit vom Kundenauftrag bis zur Herstellung und Lieferung zu reduzieren.

Dieser Trend hat erhebliche Auswirkungen auf Originalhersteller (OEMs) und Industrieausrüster, die Kabel als Komponenten ihrer eigenen Produkte verwenden, darunter:

- Werkzeugmaschinenindustrie
- Hersteller von Industrierobotern
- Spezialmaschinenhersteller
- Entwickler und Einrichter industrieller LANs
- Konfektionäre
- Kabelhändler

Originalhersteller und Industrieausrüster haben hohe Erwartungen an Kabelhersteller. Sie möchten nicht-wertschöpfende Prozesse aus dem Produktionsablauf eliminieren. Sie benötigen Flexibilität für die Kleinserienfertigung und schnelle Umstellmöglichkeiten in der eigenen Produktion und der ihrer Kunden. Sie verlangen komplette Produkte, die die Konnektivität, die System-

integration und die verteilte Steuerung erleichtern. Sie erwarten, dass Kabel den Belastungen eines rauen Produktionsumfeldes dauerhaft standhalten, gegen hohe elektromagnetische Störungen beständig und sowohl für Personal als auch Anlagen sicher sind. In einer immer stärker integrierten Welt erwarten sie zudem, dass Kabel strenge internationale Standards erfüllen und individuellen Branchenspezifikationen entsprechen. Und schließlich verlangen sie ein hohes Serviceniveau – vom ersten Preisangebot und der Auftragsbearbeitung bis hin zum Kundendienst und der Betriebsgarantie.

# Nexans cables enhance automation efficiency

## Nexans automation cables

- A full range of types for all common industry standards
- High system performance with superior cable designs
- Improved processing efficiency, and thus reduced harnessing cost.
- High resistance to oil, corrosion and heat
- Compliant with international standards, like VDE, UL, CSA
- Continuous life-testing on series run
- Flame-retardant and halogen-free for enhanced safety

### Chain Cables/Control Cables (page 12 - 39)

#### Chain Cables

- Shorter time for cables and connector assembly
- No insulation shrinkage after cutting
- No hydrolytic behavior of insulation (whereby water causes decomposition)
- Improved electrical and mechanical characteristics
- EMC optimized constructions guaranteeing low susceptibility to interference



#### Control Cables

- Easily strippable
- Multi-standard cables available
- Halogen-free miniaturized cables



### Robotic Cables (page 40 - 41)

- Durable cable design reduces downtime
- Optimized conductor and insulation materials
- Guaranteed life cycles reduce service costs
- Superior materials



### BUS Cables (page 53 - 70)

- All industry standards supported
- Specific variants for extreme environments: i.e. corrosion, heat,
- Flexibility, direct buried, etc.
- Easily strippable
- Special designs to maintain electrical parameters until end-of-life for flexible cables



### Sensor Cables (page 71 - 72)

- High oil-resistant materials
- Excellent automatic processing
- Special cross-linked sheathed materials available



The following pages are including an abstract of our product spectrum. Further cables are available on request. Also special designs according to customer requirements are a part of Nexans strength in Nuremberg.

# Nexans Kabel für die effiziente Automation

## Nexans Leitungen für die Automation

- Die vollständige Auswahl an Typen für alle gängigen Industriestandards
- Hochleistungsperformance mit anspruchsvollen Leitungsaufbauten
- Verbesserte Prozeßeffizienz und dadurch reduzierte Konfektionskosten.
- Hohe Öl-, Korrosivitäts- und Wärmebeständigkeit
- Konform mit internationalen Standards, wie VDE, UL, CSA
- Regelmäßige Schleppketten- und Torsionstests
- Flammwidrig und halogenfrei für erhöhte Sicherheit.

### Schleppleitungen/Steuerleitungen (Seite 12 - 39)

#### Schleppleitungen)

- Kürzere Montagezeiten für Kabel- und Stecker
- Keine Schrumpfung der Isolierung nach dem Schneiden
- Kein hydrolytisches Verhalten der Isolierung (somit keine Wasseraufnahme)
- Verbesserte elektrische und mechanische Eigenschaften
- EMV-optimierter Aufbau gewährleistet eine geringe Interferenzanfälligkeit



#### Steuerleitungen

- Leicht abisolierbar
- Multi-Standard-Leitungen erhältlich
- Halogenfreie miniaturisierte Kabel



### Roboterleitungen (Seite 40 - 41)

- Dauerhaftes Kabeldesign reduziert Ausfallzeiten
- Optimierte Leiter- und Isoliermaterialien
- Garantierte Lebenszyklen senken Wartungskosten
- Hochwertige Materialien



### BUS-Leitungen (Seite 53 - 70)

- Unterstützung sämtlicher Branchenstandards
- Spezialvarianten für extreme Umgebungsbedingungen, z.B. Korrosion, Hitze
- Flexibilität, direkt erdverlegbar etc.
- Leicht abisolierbar
- Spezialausführungen zur Erhaltung elektrischer Parameter bis Lebensdauerende für flexible Kabel



### Sensorleitungen (Seite 71 - 72)

- Hohe Ölbeständigkeit
- Ausgezeichnete automatische Verarbeitung
- Schweißperlenbeständige Materialien erhältlich



Die folgenden Seiten enthalten einen Auszug aus unserem Produktspektrum. Weitere Leitungen sind auf Anfrage verfügbar. Auch spezielle Sonderkonstruktionen auf Kundenwunsch gehören zu den Stärken von Nexans Nürnberg.

To meet the challenge of automation, Nexans provides a comprehensive range of cables to assure the interconnection, control and efficient process of machines and flowlines.

*Nexans bietet eine umfassende Produktpalette um den Anforderungen der Automation gerecht zu werden.*

	Chain Capability Categories <i>Schlepp Fähigkeits Klassen (SFK)</i>	8 - 9
	Abbreviations/Pictographs <i>Abkürzungen/Piktogramme</i>	10 - 11
<b>Chain cables</b> <b>Schleppfähige Leitungen</b>	PVC Control Cable unscreened 300/500 V <i>PVC Steuerleitung ungeschirmt 300/500 V</i>	12 - 13
	PVC Power Cable unscreened 600/1.000 V <i>PVC Leistungsleitung ungeschirmt 600/1.000 V</i>	14 - 15
	PUR Control Cable unscreened 300/500 V <i>PUR Steuerleitung ungeschirmt 300/500 V</i>	16 - 17
	PUR Power Cable unscreened 600/1.000 V <i>PUR Leistungsleitung ungeschirmt 600/1.000 V</i>	18 - 19
	PUR Power Cable screened 600/1.000 V <i>PUR Leistungsleitung geschirmt 600/1.000 V</i>	20 - 21
	PUR Control Cable screened 300/500 V <i>PUR Steuerleitung geschirmt 300/500 V</i>	22 - 23
	PVC Feedback and Motor Cable 30 V + 600/1.000 V acc. SIEMENS Standard 6FX 5008- <i>PVC Geber- und Motorleitung 30 V + 600/1.000 V nach SIEMENS Standard 6FX 5008-</i>	24 - 25
	PUR Feedback and Motor Cable 30 V acc. SIEMENS Standard 6FX 8008- <i>PUR Geber- und Motorleitung 30 V nach SIEMENS Standard 6FX 8008-</i>	26 - 27
	PUR Servo Motor Cable without pair 600/1.000 V acc. SIEMENS Standard 6FX 8008- <i>PUR Servo Motorleitung ohne Paar 600/1.000 V nach SIEMENS Standard 6FX 8008-</i>	28 - 29
	PUR Servo Motor Cable with pair 600/1.000 V acc. SIEMENS Standard 6FX 8008- <i>PUR Servo Motorleitung mit Paar 600/1.000 V nach SIEMENS Standard 6FX 8008-</i>	30 - 31

## Content / Inhalt

### Page / Seite

<p>PUR Servo Motor Cable 600/1.000 V acc. INDRAMAT Standard <i>PUR Servo Motorleitung 600/1.000 V nach INDRAMAT Standard</i></p>	32 - 33
<p>PUR Control Cable 300 V acc. INDRAMAT Standard <i>PUR Steuerleitung 300 V nach INDRAMAT Standard</i></p>	34 - 35
<p>PUR Linear Motor Cable with inner jacket 600/1.000 V <i>PUR Linear Motorleitung mit Innenmantel 600/1.000 V</i></p>	36 - 37
<p>PUR Servo Motor Cable with inner jacket 600/1.000 V <i>PUR Servo Motorleitung mit Innenmantel 600/1.000 V</i></p>	38 - 39
<p><b>Robot cables</b> <b>Robotik Leitungen</b></p>	<p>Torsion Cable for 3 dimensional motion <i>Torsionsleitung für 3-dimensionale Bewegung</i></p> <p>40 - 41</p> <p>Installation Instruction <i>Hinweise zur Installation</i></p> <p>42 - 45</p> <p>Assets of the robot trailing cables <i>Vorteile der Roboter-Schleppkabel</i></p> <p>46 - 47</p> <p>Special cables for drag chains <i>Spezielle Schleppkettenleitungen</i></p> <p>48</p>
<p><b>BUS cables</b> <b>BUS Leitungen</b></p>	<p>General Information/ <i>Allgemeine Information</i> Why BUS Systems? / <i>Warum BUS Systeme?</i></p> <p>50 - 52</p> <p><b>BUS Types and Sensor BUS / <i>BUS Types und Sensor BUS</i></b></p> <p>AS-Interface Bus 53 - 54</p> <p>Interbus 55 - 56</p> <p>Profibus Cable 57 - 60</p> <p>Hybrid Bus Cable 61 - 62</p> <p>Profibus PA 63 - 64</p> <p>Industrial Ethernet/Profinet Cable 65 - 66</p> <p>Can-Bus Cable 67 - 68</p> <p>DeviceNet 69 - 70</p>
<p><b>Sensor cables</b> <b>Sensorleitungen</b></p>	<p>Sensor Cable / <i>Sensorleitungen</i></p> <p>71 - 72</p> <p>Technical Data BUS Cables / <i>Technische Daten Busleitungen</i></p> <p>73 - 74</p> <p>Checklist for enquiries / <i>Anfragencheckliste</i></p> <p>75 - 76</p>

## Chain capability categories Schleppfähigkeits-Klassen

min. bending radius in permanent movement <i>min. Biegeradius bei Dauerbewegung</i>	
max. acceleration <i>max. Beschleunigung</i>	
max. speed <i>max. Verfahrgeschwindigkeit</i>	@ 1,5 m operating way / <i>Verfahrweg</i> @ 5 m operating way / <i>Verfahrweg</i> @ 7 m operating way / <i>Verfahrweg</i> @ 10 m operating way / <i>Verfahrweg</i> @ 15 m operating way / <i>Verfahrweg</i>
movements (accelerate - drive - brake) <i>Bewegungen (beschleunigen - fahren - bremsen)</i>	@ 10 x D @ 12 – 15 x D
bending cycles <i>Biegezyklen</i>	@ 7 x D @ 10 x D @ 12 – 15 x D
max. horizontal operating way <i>max. horizontale Verfahrweglänge</i>	@ max. 2 m/sec <sup>2</sup> @ max. 5 m/sec <sup>2</sup> @ max. 6 m/sec <sup>2</sup> + max. 70 m/min. @ max. 10 m/sec <sup>2</sup> + max. 140 m/min. @ max. 20 m/sec <sup>2</sup> + max. 200 m/min. @ max. 30 m/sec <sup>2</sup> + max. 360 m/min.
max. vertical operating way <i>max. vertikale Verfahrweglänge</i>	@ max. 5 m/sec <sup>2</sup> @ max. 6 m/sec <sup>2</sup> + max. 200 m/min. @ max. 10 m/sec <sup>2</sup> + max. 200 m/min. @ max. 20 m/sec <sup>2</sup> + max. 360 m/min. @ max. 30 m/sec <sup>2</sup> + max. 360 m/min.

\* D = outer diameter in mm / *Leitungsdurchmesser in mm*

\*\* 200 m/min <= 4 mm<sup>2</sup>

\*\*\* data in conceptphase, partly tested and partly finished / *Werte in Konzeptphase, zum Teil getestet und zum Teil abgeschlossen*

## Chain capability categories Schleppfähigkeits-Klassen

SFK 1 (similar to MC 500) (ähnlich MC 500)	SFK 2 (BUS cables) (BUS Leitungen)	SFK 3 (Sensor cables) (Sensor Leitungen)	SFK 4 (similar to MC 800) (ähnlich MC 800) SN 80 003	SFK 5	SFK 6 (with inner jacket) (mit Innenmantel) SN 80 004	SFK 7 (in conceptphase) (Konzeptphase) SN 80 007
18 x D*	12 – 15 x D*	10 – 12 x D*	10 x D*		10 x D*	7 x D*
2 m/sec <sup>2</sup>	2 m/sec <sup>2</sup>	5 m/sec <sup>2</sup>	5 m/sec <sup>2</sup>		20 m/sec <sup>2</sup>	30 m/sec <sup>2</sup>
30 m/min.	200 m/min.	200 m/min.	120 m/min.**		200 m/min. 140 m/min. 100 m/min. 70 m/min.	360 m/min. 240 m/min. 260 m/min. 220 m/min. 180 m/min.
1 Mio.	2 – 4 Mio.	6 Mio.	10 Mio.		10 Mio.	20 Mio.
0.1 Mio. 0.5 Mio.	1 – 2 Mio.	2 Mio. 3 Mio.	5 Mio.		5 Mio. 10 Mio.	10 Mio. 20 Mio.
5 m	5 m	5 m	5 m		15 m 7 m 2 m	15 m*** 7 m*** 2 m*** 1,5 m***
	2 m				5 m 2,5 m 1 m	5 m*** 3 m*** 1,5 m*** 0,5 m***



## Abbreviations in accordance with VDE *Abkürzungen entsprechend VDE*

<b>Compounds</b> <i>Werkstoffe</i>	Y	= PVC	
	9Y	= TPM - PP Polypropylene Modified	
	11Y	= TPE-U Polyurethane	
	13Y	= TPE-E Thermoplastic Polyester Elastomere	
	18Y	= TPE-E Santoprene	
<b>Elements</b> <i>Elemente</i>	c / A	= core	<i>Ader</i>
	pr / P	= pair	<i>Paar</i>
	V	= quad	<i>Vierer</i>
	Bd	= bundle	<i>Bündel</i>
<b>Screen</b> <i>Schirm</i>	C	= braid of copper wires	<i>Kupfergeflecht</i>
	D	= spiralized copper wires	<i>Kupferumseilung</i>
	St	= metal film (tape, foil)	<i>Statischer Schirm (Band, Folie)</i>
<b>AWG measurements</b> <i>AWG Messgrößen</i>	AWG 26	≈ 0,14mm <sup>2</sup>	
	AWG 24	≈ 0,25mm <sup>2</sup>	
	AWG 22	≈ 0,34mm <sup>2</sup>	
	AWG 20	≈ 0,50mm <sup>2</sup>	
	AWG 19	≈ 0,75mm <sup>2</sup>	
	AWG 18	≈ 1,00mm <sup>2</sup>	
	AWG 16	≈ 1,50mm <sup>2</sup>	
	AWG 14	≈ 2,50mm <sup>2</sup>	
	AWG 12	≈ 4,00mm <sup>2</sup>	
	AWG 10	≈ 6,00mm <sup>2</sup>	
	AWG 8	≈ 10,0mm <sup>2</sup>	
	AWG 6	≈ 16,0mm <sup>2</sup>	
	AWG 4	≈ 25,0mm <sup>2</sup>	
	AWG 2	≈ 35,0mm <sup>2</sup>	
	AWG 1	≈ 50,0mm <sup>2</sup>	
<b>Other abbreviations</b> <i>Andere Abkürzungen</i>	PSL	= power chain cable	<i>Power-Schleppleitung</i>
	SSL	= control chain cable	<i>Steuer-Schleppleitung</i>
	TL	= torsion cable	<i>Torsionsleitung</i>
	EMC EMV	= electromagnetic compatibility <i>elektromagnetische Verträglichkeit</i>	
	DESINA	= DEcentralized and Standardized INstAllation technology Overall concept for the standardization and decentralization of the electric installation of machines and facilities of VDW (Association of German machine tool equipment manufacturers) <i>DEzentrale und Standardisierte INstAllationstechnik</i>	

# Pictographs Piktogramme

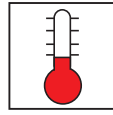

Operating temperature  
*Zulässige Betriebstemperatur in unbewegtem Zustand*

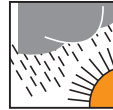

Weather proof  
*Witterungsbeständig*



Mechanical resistance  
*Mechanische Beständigkeit*

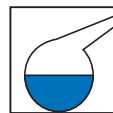

Chemical resistance  
*Chemikalienbeständig*



Flame retardant  
*Flammwidrig*



Low smoke  
*Raucharm*

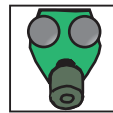

Low toxic  
*Niedrige Toxizität*



Non corrosive  
*Nicht korrosiv*



Flexibility  
*Flexibel*



Oil resistance  
*Ölbeständig*



Halogen free  
*Halogenfrei*



Lead free  
*Bleifrei*



Electro Magnetic Interference (EMI)  
*Elektromagnetische Verträglichkeit (EMV)*

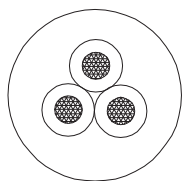

# PVC Control Cable unscreened PVC Steuerleitung ungeschirmt

**300/500 V**

## Type Approval Certificates

acc. to VDE 300/500 V  
UL 80 °C 300 V  
UL Core Style 10493  
UL Sheath Style 2464

## Applications

Control cables for use in energy chains  
up to 5 Mio. bending cycles according  
SFK 6

## Zulassungen

in Anlehnung an VDE 300/500 V  
UL 80 °C 300 V  
UL Aderstyle 10493  
UL Mantelstyle 2464

## Anwendung

Steuerleitungen für die Verwendung in  
Schleppketten bis zu 5 Mio. Biegezyklen  
nach SFK 6 (Schlepp-Fähigkeits-Klasse)

<b>SFK</b> Schlepp-Fähigkeits-Klasse						<b>6</b>	7
1	2	3	4	5	6	7	

## Design

- Conductor**  
bare copper class 6
- Insulation**  
TPM - PP modified (9Y)

- Outer sheath**  
PVC (Y) – gap filling  
grau – RAL 7040

## Aufbau

- Leiter**  
Kupfer blank Klasse 6
- Isolierung**  
TPM - PP modifiziert (9Y)

- Außenmantel**  
PVC (Y) – zwickelfüllend  
grau – RAL 7040



## Marking

cross section  
+ approvals  
+ date of production

## Core identification







black cores with white numbers  
+ green/yellow

## Bedruckung

Querschnitt  
+ Zulassungen  
+ Produktionsdatum

## Aderkennzeichnung

Schwarze Adern mit weißem  
Ziffernaufdruck + grün/gelb

					
-25 °C to +80 °C	no	yes	no	yes	yes

**PVC Control Cable unscreened**  
**PVC Steuerleitung ungeschirmt**

Type	Construction	AWG	Article no.	Outer diameter approx. mm	Copper weight kg/km	Total weight kg/km
Typ	Aufbau	AWG	Artikelnummer	Außendurchmesser ca. mm	Kupferzahl kg/km	Gesamtgewicht kg/km
SSLYJ 3x0,5	3x0,5	20	493 030 3X	4,8	14 kg	33 kg
SSLYJ 4x0,5	4x0,5	20	493 031 3X	5,2	19 kg	40 kg
SSLYJ 7x0,5	7x0,5	20	493 032 3X	6,9	33 kg	69 kg
SSLYJ 12x0,5	4x3x0,5	20	493 033 3X	8,9	57 kg	105 kg
SSLYJ 18x0,5	6x3x0,5	20	493 034 3X	11,1	87 kg	150 kg
SSLYJ 25x0,5	5x5x0,5	20	493 035 3X	13,2	121 kg	221 kg
SSLY 2x0,75	2x0,75	19	493 036 3X	5,1	15 kg	37 kg
SSLYJ 3x0,75	3x0,75	19	493 037 3X	5,4	20 kg	47 kg
SSLYJ 5x0,75	5x0,75	19	493 038 3X	6,2	35 kg	60 kg
SSLYJ 7x0,75	7x0,75	19	493 039 3X	7,2	49 kg	81 kg
SSLYJ 12x0,75	4x3x0,75	19	493 040 3X	9,8	85 kg	141 kg
SSLYJ 18x0,75	6x3x0,75	19	493 041 3X	13,3	127 kg	219 kg
SSLYJ 25x0,75	5x5x0,75	19	493 042 3X	14,7	178 kg	286 kg
SSLY 2x1,0	2x1,0	18	493 043 3X	5,4	19 kg	41 kg
SSLYJ 3x1,0	3x1,0	18	493 044 3X	5,7	28 kg	54 kg
SSLYJ 4x1,0	4x1,0	18	493 045 3X	6,2	37 kg	61 kg
SSLYJ 5x1,0	5x1,0	18	493 046 3X	6,7	47 kg	74 kg
SSLYJ 7x1,0	7x1,0	18	493 047 3X	7,9	66 kg	98 kg
SSLYJ 12x1,0	4x3x1,0	18	493 048 3X	10,8	113 kg	173 kg
SSLYJ 18x1,0	6x3x1,0	18	493 049 3X	14,0	170 kg	260 kg
SSLYJ 24x1,0	6x4x1,0	18	493 050 3X	16,6	228 kg	352 kg
SSLYJ 25x1,0	5x5x1,0	18	493 051 3X	16,5	238 kg	366 kg
SSLYJ 36x1,0	6x6x1,0	18	493 052 3X	20,3	345 kg	553 kg

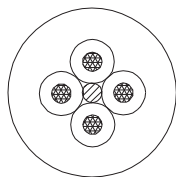

# PVC Power Cable unscreened

## PVC Leistungsleitung ungeschirmt

**600/1.000 V**

### Type Approval Certificates

acc. to VDE 600/1.000 V  
UL/CSA 80 °C 600 or 1.000 V  
UL Core Style 10492  
UL Sheath Style 2570

### Applications

Power cables for use in energy chains  
up to 5 Mio. bending cycles according  
SFK 6

### Zulassungen

in Anlehnung an VDE 600/1.000 V  
UL/CSA 80 °C 600 oder 1.000 V  
UL Aderstyle 10492  
UL Mantelstyle 2570

### Anwendung

Leistungsleitungen für die Verwendung in  
Schleppketten bis zu 5 Mio. Biegezyklen  
nach SFK 6 (Schlepp-Fähigkeits-Klasse)



### Design

1. **Conductor**  
bare copper class 6
2. **Insulation**  
TPM - PP modified (9Y)

3. **Outer sheath**  
PVC (Y) – gap filling  
black – RAL 9005

### Aufbau

1. **Leiter**  
Kupfer blank Klasse 6
2. **Isolierung**  
TPM - PP modifiziert (9Y)

3. **Außenmantel**  
PVC (Y) – zwickelfüllend  
schwarz – RAL 9005



### Marking

cross section  
+ approvals  
+ date of production

### Core identification

black cores with white numbers  
+ green/yellow

### Bedruckung

Querschnitt  
+ Zulassungen  
+ Produktionsdatum

### Aderkennzeichnung

Schwarze Adern mit weißem  
Ziffernaufdruck + grün/gelb

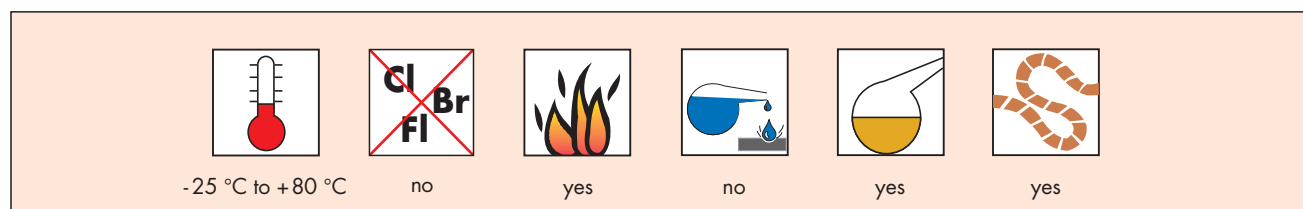

**PVC Power Cable unscreened**  
**PVC Leistungsleitung ungeschirmt**

Type	Construction	AWG	Article no.	Outer diameter approx. mm	Copper weight kg/km	Total weight kg/km
Typ	Aufbau	AWG	Artikelnummer	Außendurchmesser ca. mm	Kupferzahl kg/km	Gesamtgewicht kg/km
PSLYJ 3x1,5	3x1,5	16	493 170 1X	7,4	41 kg	88 kg
PSLYJ 4x1,5	4x1,5	16	493 171 1X	8,0	56 kg	106 kg
PSLYJ 5x1,5	5x1,5	16	493 172 1X	8,7	70 kg	126 kg
PSLYJ 7x1,5	7x1,5	16	493 173 1X	10,5	99 kg	178 kg
PSLYJ 12x1,5	4x3x1,5	16	493 174 1X	13,7	171 kg	287 kg
PSLYJ 18x1,5	6x3x1,5	16	493 175 1X	17,4	258 kg	433 kg
PSLYJ 25x1,5	5x5x1,5	16	493 176 1X	21,3	339 kg	624 kg
PSLYJ 4x2,5	4x2,5	14	493 177 1X	9,7	93 kg	165 kg
PSLYJ 5x2,5	5x2,5	14	493 178 1X	10,6	112 kg	191 kg
PSLYJ 7x2,5	7x2,5	14	493 179 1X	12,3	164 kg	266 kg
PSLYJ 12x2,5	4x3x2,5	14	493 180 1X	18,7	282 kg	520 kg
PSLYJ 18x2,5	6x3x2,5	14	493 181 1X	22,2	426 kg	738 kg
PSLYJ 25x2,5	5x5x2,5	14	493 182 1X	26,6	595 kg	1.042 kg
PSLYJ 4x4	4x4	12	493 183 1X	10,9	151 kg	233 kg
PSLYJ 5x4	5x4	12	493 184 1X	12,4	189 kg	284 kg
PSLYJ 7x4	7x4	12	493 185 1X	14,4	267 kg	393 kg
PSLYJ 4x6	4x6	10	493 186 1X	12,8	224 kg	333 kg
PSLYJ 7x6	7x6	10	493 187 1X	17,6	396 kg	580 kg
PSLYJ 4x10	4x10	8	493 188 1X	15,0	391 kg	518 kg
PSLYJ 4x16	4x16	6	493 189 1X	19,6	620 kg	841 kg
PSLYJ 4x25	4x25	4	493 190 1X	24,1	965 kg	1.301 kg
PSLYJ 4x35	4x35	2	493 191 1X	27,8	1.341 kg	1.721 kg

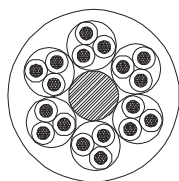

# PUR Control Cable unscreened

## PUR Steuerleitung ungeschirmt

**300/500 V**

### Type Approval Certificates

acc. to VDE 300/500 V  
UL/CSA 80 °C 300 V  
UL Core Style 10493  
UL Sheath Style 20317

### Applications

Control cables for use in energy chains  
up to 5 Mio. bending cycles according  
SFK 6

### Zulassungen

in Anlehnung an VDE 300/500 V  
UL/CSA 80 °C 300 V  
UL Aderstyle 10493  
UL Mantelstyle 20317

### Anwendung

Steuerleitungen für die Verwendung in  
Schleppketten bis zu 5 Mio. Biegezyklen  
nach SFK 6 (Schlepp-Fähigkeits-Klasse)

<b>SFK</b> Schlepp-Fähigkeits-Klasse						<b>6</b>	7
1	2	3	4	5	6	7	

### Design

- 1. Conductor**  
bare copper class 6
- 2. Insulation**  
TPM - PP modified (9Y)

- 3. Outer sheath**  
PUR (11Y) – gap filling  
black – RAL 9005

### Aufbau

- 1. Leiter**  
Kupfer blank Klasse 6
- 2. Isolierung**  
TPM - PP modifiziert (9Y)

- 3. Außenmantel**  
PUR (11Y) – zwickelfüllend  
schwarz – RAL 9005



### Marking

cross section  
+ approvals  
+ date of production

### Core identification







black cores with white numbers  
+ green/yellow

### Bedruckung

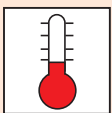
Querschnitt  
+ Zulassungen  
+ Produktionsdatum

### Aderkennzeichnung

Schwarze Adern mit weißem  
Ziffernaufdruck + grün/gelb

					
-50 °C to +80 °C	yes	yes	yes	yes	yes

**PUR Control Cable unscreened**  
**PUR Steuerleitung ungeschirmt**

Type	Construction	AWG	Article no.	Outer diameter approx. mm	Copper weight kg/km	Total weight kg/km
Typ	Aufbau	AWG	Artikelnummer	Außendurchmesser ca. mm	Kupferzahl kg/km	Gesamtgewicht kg/km
SSL11Y 2x0,5	2x0,5	20	493 370 1X	4,6	10 kg	29 kg
SSL11Y-J 3x0,5	3x0,5	20	493 371 1X	4,8	14 kg	33 kg
SSL11Y-J 4x0,5	4x0,5	20	493 372 1X	5,2	20 kg	44 kg
SSL11Y-J 5x0,5	5x0,5	20	493 373 1X	5,3	24 kg	47 kg
SSL11Y-J 7x0,5	7x0,5	20	493 374 1X	6,6	33 kg	62 kg
SSL11Y-J 12x0,5	4x3x0,5	20	493 375 1X	9,2	57 kg	112 kg
SSL11Y-J 18x0,5	6x3x0,5	20	493 376 1X	11,1	87 kg	153 kg
SSL11Y-J 25x0,5	5x5x0,5	20	493 377 1X	13,2	117 kg	231 kg
SSL11Y 2x0,75	2x0,75	19	493 369 1X	5,1	14 kg	36 kg
SSL11Y-J 3x0,75	3x0,75	19	493 378 1X	5,3	21 kg	41 kg
SSL11Y-J 4x0,75	4x0,75	19	493 379 1X	5,9	30 kg	56 kg
SSL11Y-J 5x0,75	5x0,75	19	493 380 1X	6,2	35 kg	60 kg
SSL11Y-J 7x0,75	7x0,75	19	493 381 1X	7,2	49 kg	92 kg
SSL11Y-J 12x0,75	4x3x0,75	19	493 382 1X	10,3	85 kg	157 kg
SSL11Y-J 18x0,75	6x3x0,75	19	493 383 1X	13,3	127 kg	230 kg
SSL11Y-J 25x0,75	5x5x0,75	19	493 384 1X	14,7	178 kg	284 kg
SSL11Y-J 3x1,0	3x1,0	18	493 385 1X	5,7	28 kg	50 kg
SSL11Y-J 4x1,0	4x1,0	18	493 386 1X	6,2	37 kg	61 kg
SSL11Y-J 5x1,0	5x1,0	18	493 387 1X	6,7	47 kg	73 kg
SSL11Y-J 6x1,0	6x1,0	18	493 388 1X	7,3	56 kg	86 kg
SSL11Y-J 7x1,0	7x1,0	18	493 389 1X	7,9	66 kg	109 kg
SSL11Y-J 8x1,0	8x1,0	18	493 390 1X	8,9	75 kg	114 kg
SSL11Y-J 9x1,0	9x1,0	18	493 391 1X	9,3	85 kg	127 kg
SSL11Y-J 12x1,0	4x3x1,0	18	493 392 1X	10,8	114 kg	179 kg
SSL11Y-J 18x1,0	6x3x1,0	18	493 393 1X	14,9	168 kg	290 kg
SSL11Y-J 25x1,0	5x5x1,0	18	493 394 1X	16,5	238 kg	374 kg



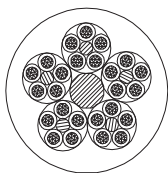

# PUR Power Cable unscreened

## PUR Leistungsleitung ungeschirmt

**600/1.000 V**

### Type Approval Certificates

in acc. to VDE 600/1.000 V  
UL/CSA 80 °C 1.000 V  
UL (single) Core Style 10492/10553  
UL Sheath Style 20234

### Applications

Power cables for use in energy chains  
up to 5 Mio. bending cycles according  
SFK 6

### Zulassungen

in Anlehnung an VDE 600/1.000 V  
UL/CSA 80 °C 1.000 V  
UL (Einzel-) Aderstyle 10492/10553  
UL Mantelstyle 20234

### Anwendung

Leistungsleitungen für die Verwendung in  
Schleppketten bis zu 5 Mio. Biegezyklen  
nach SFK 6 (Schlepp-Fähigkeits-Klasse)



### Design

1. **Conductor**  
bare copper class 6
2. **Insulation**  
TPM - PP modified (9Y)

3. **Outer sheath**  
PUR (11Y) – gap filling  
black – RAL 9005

### Aufbau

1. **Leiter**  
Kupfer blank Klasse 6
2. **Isolierung**  
TPM - PP modifiziert (9Y)

3. **Außenmantel**  
PUR (11Y) – zwickelfüllend  
schwarz – RAL 9005



### Marking

cross section  
+ approvals  
+ date of production

### Core identification

black cores with white numbers  
+ green/yellow

### Bedruckung

Querschnitt  
+ Zulassungen  
+ Produktionsdatum

### Aderkennzeichnung

Schwarze Adern mit weißem  
Ziffernaufdruck + grün/gelb

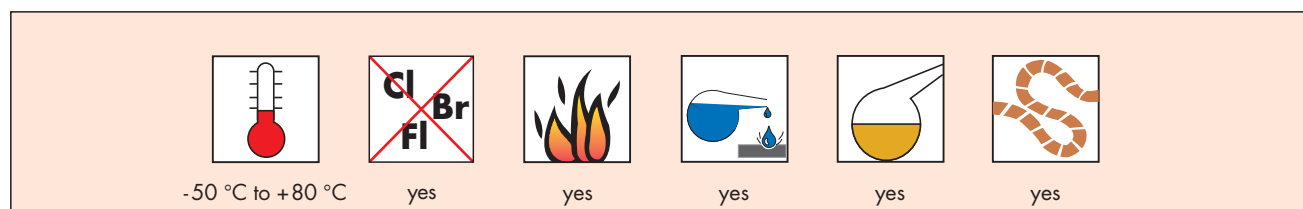

**PUR Power Cable unscreened**  
**PUR Leistungsleitung ungeschirmt**

Type	Construction	AWG	Article no.	Outer diameter approx. mm	Copper weight kg/km	Total weight kg/km
Typ	Aufbau	AWG	Artikelnummer	Außendurchmesser ca. mm	Kupferzahl kg/km	Gesamtgewicht kg/km
PSL11YJ 3x1,5	3x1,5	16	493 450 1X	7,4	42 kg	84 kg
PSL11YJ 4x1,5	4x1,5	16	493 451 1X	8,0	56 kg	105 kg
PSL11YJ 5x1,5	5x1,5	16	493 452 1X	8,7	70 kg	126 kg
PSL11YJ 7x1,5	7x1,5	16	493 453 1X	10,5	96 kg	171 kg
PSL11YJ 12x1,5	4x3x1,5	16	493 454 1X	13,7	164 kg	285 kg
PSL11YJ 18x1,5	6x3x1,5	16	493 455 1X	16,7	258 kg	406 kg
PSL11YJ 25x1,5	5x5x1,5	16	493 456 1X	20,9	339 kg	604 kg
PSL11YJ 36x1,5	6x6x1,5	16	493 457 1X	24,7	523 kg	879 kg
PSL11YJ 3x2,5	3x2,5	14	493 474 1X	8,9	69 kg	127 kg
PSL11YJ 4x2,5	4x2,5	14	493 475 1X	9,7	93 kg	157 kg
PSL11YJ 5x2,5	5x2,5	14	493 476 1X	10,6	116 kg	194 kg
PSL11YJ 7x2,5	7x2,5	14	493 478 1X	12,3	163 kg	261 kg
PSL11YJ 12x2,5	4x3x2,5	14	493 480 1X	17,6	282 kg	472 kg
PSL11YJ 18x2,5	6x3x2,5	14	493 498 1X	23,0	426 kg	672 kg
PSL11YJ 25x2,5	5x5x2,5	14	493 499 1X	25,6	595 kg	970 kg
PSL11YJ 4x4	4x4	12	493 481 1X	10,9	151 kg	229 kg
PSL11YJ 7x4	7x4	12	493 483 1X	14,4	267 kg	372 kg
PSL11YJ 4x6	4x6	10	493 484 1X	13,1	222 kg	324 kg
PSL11YJ 5x6	5x6	10	493 471 1X	14,4	281 kg	402 kg
PSL11YJ 7x6	7x6	10	493 472 1X	16,9	396 kg	536 kg
PSL11YJ 4x10	4x10	8	493 485 1X	16,4	383 kg	519 kg
PSL11YJ 5x10	5x10	8	493 497 1X	16,7	491 kg	612 kg
PSL11YJ 4x16	4x16	6	493 486 1X	18,6	603 kg	777 kg
PSL11YJ 4x25	4x25	4	493 487 1X	23,0	965 kg	1.221 kg
PSL11YJ 4x35	4x35	2	493 488 1X	26,6	1.330 kg	1.663 kg
PSL9Y11Y 1x1,5	1x1,5	16	493 464 1X	5,3	14 kg	39 kg
PSL9Y11Y 1x2,5	1x2,5	14	493 465 1X	5,8	22 kg	51 kg
PSL9Y11Y 1x4	1x4	12	493 466 1X	6,3	37 kg	67 kg
PSL9Y11Y 1x6	1x6	10	493 467 1X	6,9	55 kg	88 kg
PSL9Y11Y 1x10	1x10	8	493 468 1X	7,8	95 kg	135 kg
PSL9Y11Y 1x16	1x16	6	493 469 1X	9,2	151 kg	199 kg
PSL9Y11Y 1x25	1x25	4	493 470 1X	10,8	235 kg	294 kg
PSL9Y11Y 1x35	1x35	2	493 489 1X	12,2	333 kg	397 kg
PSL9Y11Y 1x50	1x50	1	493 490 1X	14,2	469 kg	546 kg
PSL9Y11Y 1x70	1x70	2/0	493 491 1X	15,7	634 kg	717 kg
PSL9Y11Y 1x95	1x95	3/0	493 492 1X	17,5	912 kg	933 kg
PSL9Y11Y 1x120	1x120	4/0	493 493 1X	19,3	1.140 kg	1.229 kg
PSL9Y11Y 1x150	1x150	300 KCMIL	493 494 1X	22,2	1.413 kg	1.548 kg
PSL9Y11Y 1x185	1x185	350 KCMIL	493 495 1X	24,5	1.746 kg	1.903 kg

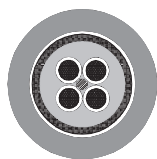

# PUR Power Cable screened PUR Leistungsleitung geschirmt

**600/1.000 V**

## Type Approval Certificates

in acc. to VDE 600/1.000 V  
UL/CSA 80 °C 1.000 V  
UL (single) core Style 10492/10553  
UL Sheath Style 20234

## Applications

Power cables for use in energy chains  
up to 5 Mio. bending cycles according  
SFK 6

## Zulassungen

in Anlehnung an VDE 600/1.000 V  
UL/CSA 80 °C 1.000 V  
UL (Einzel-) Aderstyle 10492/10553  
UL Mantelstyle 20234

## Anwendung

Leistungsleitungen für die Verwendung in  
Schleppketten bis zu 5 Mio. Biegezyklen  
nach SFK 6 (Schlepp-Fähigkeits-Klasse)



## Design

1. **Conductor**  
bare copper class 6
2. **Insulation**  
TPM - PP modified (9Y)
3. **Inner sheath**  
TPE (18Y)

4. **Screen**  
tinned copper braid
3. **Inner sheath**  
PUR (11Y)  
orange – RAL 2003

## Aufbau

1. **Leiter**  
Kupfer blank Klasse 6
2. **Isolierung**  
TPM - PP modifiziert (9Y)
3. **Innenmantel**  
TPE (18Y)

4. **Schirm**  
Kupfergeflecht, verzinkt
3. **Außenmantel**  
PUR (11Y)  
orange – RAL 2003



## Marking

cross section  
+ approvals  
+ date of production

## Core identification







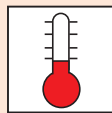

black cores with white numbers  
+ green/yellow

## Bedruckung

Querschnitt  
+ Zulassungen  
+ Produktionsdatum

## Aderkennzeichnung

Schwarze Adern mit weißem  
Ziffernaufdruck + grün/gelb

							
-35 °C to +80 °C	yes	yes	yes	yes	yes	very good	yes

**PUR Power Cable screened**  
**PUR Leistungsleitung geschirmt**

Type	Construction	AWG	Article no.	Outer diameter approx. mm	Copper weight kg/km	Total weight kg/km
Typ	Aufbau	AWG	Artikelnummer	Außendurchmesser ca. mm	Kupferzahl kg/km	Gesamtgewicht kg/km
PSL18YC11Y-J 3x1,5	3x1,5	16	493 620 6X	9,30	70 kg	138 kg
PSL18YC11Y-J 4x1,5	4x1,5	16	493 621 6X	9,90	86 kg	160 kg
PSL18YC11Y-J 5x1,5	5x1,5	16	493 622 6X	10,60	103 kg	186 kg
PSL18YC11Y-J 7x1,5	7x1,5	16	493 623 6X	12,40	141 kg	252 kg
PSL18YC11Y-J 12x1,5	4x3x1,5	16	493 624 6X	15,90	240 kg	396 kg
PSL18YC11Y-J 16x1,5	4x4x1,5	16	493 625 6X	18,60	333 kg	536 kg
PSL18YC11Y-J 18x1,5	6x3x1,5	16	493 626 6X	19,20	366 kg	568 kg
PSL18YC11Y-J 25x1,5	5x5x1,5	16	493 627 6X	23,30	467 kg	783 kg
PSL18YC11Y-J 36x1,5	6x6x1,5	16	493 618 6X	27,50	683 kg	1.134 kg
PSL18YC11Y-J 4x2,5	4x2,5	14	493 628 6X	11,70	139 kg	240 kg
PSL18YC11Y-J 5x2,5	5x2,5	14	493 629 6X	12,60	168 kg	279 kg
PSL18YC11Y-J 7x2,5	7x2,5	14	493 630 6X	14,40	212 kg	353 kg
PSL18YC11Y-J 4x4,0	4x4,0	12	493 631 6X	12,90	207 kg	318 kg
PSL18YC11Y-J 4x6,0	4x6,0	10	493 632 6X	14,90	274 kg	422 kg
PSL18YC11Y-J 4x10	4x10	8	493 633 6X	17,20	467 kg	638 kg
PSL18YC11Y-J 4x16	4x16	6	493 634 6X	21,60	730 kg	991 kg
PSL18YC11Y-J 4x25	4x25	4	493 635 6X	25,50	1.100 kg	1.425 kg
PSL18YC11Y-J 4x35	4x35	2	493 636 6X	30,40	1485 kg	1.960 kg
PSL18YC11Y-J 4x50	4x50	1	493 637 6X	34,50	2134 kg	2.738 kg
PSL9YC11Y 1x2,5	1x2,5	14	493 638 6X	6,60	39 kg	74 kg
PSL9YC11Y 1x4,0	1x4,0	12	493 639 6X	7,20	61 kg	97 kg
PSL9YC11Y 1x6,0	1x6,0	10	493 640 6X	7,80	81 kg	121 kg
PSL9YC11Y 1x10	1x10	8	493 642 6X	8,80	127 kg	175 kg
PSL9YC11Y 1x16	1x16	6	493 643 6X	10,00	190 kg	244 kg
PSL9YC11Y 1x25	1x25	4	493 644 6X	11,70	286 kg	341 kg
PSL9YC11Y 1x35	1x35	2	493 645 6X	13,10	388 kg	460 kg
PSL9YC11Y 1x50	1x50	1	493 646 6X	15,10	535 kg	621 kg
PSL9YC11Y 1x70	1x70	2/0	493 647 6X	16,60	706 kg	789 kg
PSL9YC11Y 1x95	1x95	3/0	493 648 6X	19,20	1.021 kg	1.109 kg
PSL9YC11Y 1x120	1x120	4/0	493 641 6X	21,00	1.266 kg	1.401 kg
PSL9YC11Y 1x150	1x150	300 KCMIL	493 649 6X	23,30	1.544 kg	1.691 kg
PSL9YC11Y 1x185	1x185	350 KCMIL	493 650 6X	25,60	1.894 kg	2.069 kg

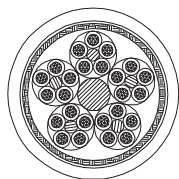

# PUR Control Cable screened PUR Steuerleitung geschirmt

**300/500 V**

## Type Approval Certificates

in acc. to VDE 300/500 V  
UL/CSA 80 °C 300 V  
UL Core Style 10493  
UL Sheath Style 20317

## Applications

Control cables for use in energy chains  
up to 5 Mio. bending cycles according  
SFK 6

## Zulassungen

in Anlehnung an VDE 300/500 V  
UL/CSA 80 °C 300 V  
UL Aderstyle 10493  
UL Mantelstyle 20317

## Anwendung

Steuerleitungen für die Verwendung in  
Schleppketten bis zu 5 Mio. Biegezyklen  
nach SFK 6 (Schlepp-Fähigkeits-Klasse)

SFK Schlepp-Fähigkeits-Klasse						<b>6</b>	7
1	2	3	4	5	6	7	

## Design

1. **Conductor**  
bare copper class 6
2. **Insulation**  
TPM - PP modified (9Y)
3. **Inner sheath**  
TPE (18Y)

4. **Screen**  
tinned copper braid
5. **Outer sheath**  
PUR (11Y)  
grey – RAL 7040



## Aufbau

1. **Leiter**  
Kupfer blank Klasse 6
2. **Isolierung**  
TPM - PP modifiziert (9Y)
3. **Innenmantel**  
TPE (18Y)

4. **Schirm**  
Kupfergeflecht, verzinkt
5. **Außenmantel**  
PUR (11Y)  
grau – RAL 7040

## Marking

cross section  
+ approvals  
+ date of production

## Core identification







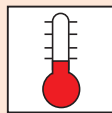

black cores with white numbers  
+ green/yellow

## Bedruckung

Querschnitt  
+ Zulassungen  
+ Produktionsdatum

## Aderkennzeichnung

Schwarze Adern mit weißem  
Ziffernaufdruck + grün/gelb

							
-50 °C to +80 °C	yes	yes	yes	yes	yes	very good	yes

**PUR Control Cable screened**  
**PUR Steuerleitung geschirmt**

Type	Construction	AWG	Article no.	Outer diameter approx. mm	Copper weight kg/km	Total weight kg/km
Typ	Aufbau	AWG	Artikelnummer	Außendurchmesser ca. mm	Kupferzahl kg/km	Gesamtgewicht kg/km
SSL18Y11YJ 3x0,5	3x0,5	20	493 530 3X	6,5	33 kg	66 kg
SSL18Y11YJ 5x0,5	5x0,5	20	493 531 3X	7,6	48 kg	90 kg
SSL18Y11YJ 7x0,5	7x0,5	20	493 532 3X	8,3	59 kg	106 kg
SSL18Y11YJ 12x0,5	4x3x0,5	20	493 533 3X	10,8	94 kg	168 kg
SSL18Y11YJ 18x0,5	6x3x0,5	20	493 534 3X	13,2	132 kg	232 kg
SSL18Y11YJ 25x0,5	5x5x0,5	20	493 535 3X	15,2	174 kg	316 kg
SSL18Y11YJ 3x0,75	3x0,75	19	493 550 3X	7,0	42 kg	77 kg
SSL18Y11YJ 4x0,75	4x0,75	19	493 551 3X	7,4	50 kg	89 kg
SSL18Y11YJ 5x0,75	5x0,75	19	493 552 3X	7,9	60 kg	102 kg
SSL18Y11YJ 7x0,75	7x0,75	19	493 553 3X	9,1	79 kg	133 kg
SSL18Y11YJ 12x0,75	4x3x0,75	19	493 554 3X	12,3	135 kg	224 kg
SSL18Y11YJ 18x0,75	6x3x0,75	19	493 555 3X	15,3	182 kg	313 kg
SSL18Y11YJ 25x0,75	5x5x0,75	19	493 556 3X	16,8	254 kg	409 kg
SSL18Y11YJ 3x1,0	3x1,0	18	493 570 3X	7,4	50 kg	89 kg
SSL18Y11YJ 4x1,0	4x1,0	18	493 571 3X	8,0	62 kg	106 kg
SSL18Y11YJ 5x1,0	5x1,0	18	493 572 3X	8,6	74 kg	124 kg
SSL18Y11YJ 7x1,0	7x1,0	18	493 573 3X	9,8	98 kg	155 kg
SSL18Y11YJ 12x1,0	4x3x1,0	18	493 574 3X	12,9	157 kg	252 kg
SSL18Y11YJ 18x1,0	6x3x1,0	18	493 575 3X	16,1	242 kg	377 kg
SSL18Y11YJ 25x1,0	5x5x1,0	18	493 576 3X	18,9	343 kg	521 kg

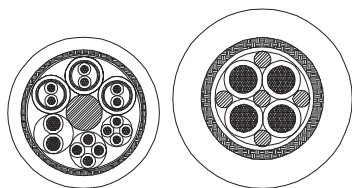

# PVC Feedback and Servo Motor Cable

acc. SIEMENS Standard 6FX 5008-

## PVC Geber- und Servomotorleitung

nach SIEMENS Standard 6FX 5008-

**Type Approval Certificates**  
UL/CSA 80 °C

**Applications**

**30 V + 600/1.000 V**

Feedback and motor cables for use in energy chains up to 0.1 Mio. bending cycles according SFK 1

### Zulassungen

UL/CSA 80 °C

### Anwendung

Geber- und Motorleitungen für die Verwendung in Schleppketten bis zu 0,1 Mio. Biegezyklen nach SFK 1 (Schlepp-Fähigkeits-Klasse)

<b>1</b>	<b>SFK</b> Schlepp-Fähigkeits-Klasse						
	2	3	4	5	6	7	

### Design

**1. Conductor**

tinned electrolyte stranded copper (feedback cables)  
bare copper (motor cables)

**2. Insulation**

TPM - PP modified (9Y)

**3. Filler (optional)**

special plastic film to cover all screens

**4. Screen**

tinned copper braid

**5. Outer sheath**

PVC  
Feedback Cable green (RAL 6018)  
Servo Motor Cable orange (RAL 2003)



### Aufbau

**1. Leiter**

verzinnter Kupferleiter (Geberleitung)  
blankes Kupfer (Motorleitung)

**2. Isolierung**

TPM - PP modifiziert (9Y)

**3. Füllelement**

spezial Folie oder Vlies

**4. Schirm**

Kupfergeflecht, verzinkt

**5. Außenmantel**

PVC  
Geberleitung grün (RAL 6018)  
Servomotorleitung orange (RAL 2003)

### Marking

cross section  
+ approvals  
+ date of production

### Core identification

acc. SIEMENS specifications

### Bedruckung

Querschnitt  
+ Zulassungen  
+ Produktionsdatum

### Aderkennzeichnung

nach SIEMENS Spezifikation

						
-25 °C to +80 °C	yes	no	yes	yes	very good	yes

**PVC Feedback and Servo Motor Cables** acc. SIEMENS Standard 6FX 5008-  
**PVC Geber- und Servomotorleitungen** nach SIEMENS Standard 6FX 5008-

Type	Construction	AWG	Article no.	Outer diameter approx. mm	Copper weight kg/km	Total weight kg/km	SIEMENS ID
Typ	Aufbau	AWG	Artikelnummer	Außendurchmesser ca. mm	Kupferzahl kg/km	Gesamtgewicht kg/km	SIEMENS ID
<b>Feedback / Geberleitung</b>							
SSLCY 12 A komb.	4x2x0,34+4x0,5	22 AWG/ 4pr + 20 AWG/ 4c	494 026 71	8,9	72 kg	117 kg	1 BD 21
SLCY 12 A komb.	3x2x0,14+2x0,5+4x0,14	26 AWG/ 3pr + 20 AWG/ 2c + 26 AWG/ 4c	494 029 71	8,9	61 kg	103 kg	1 BD 41
SSLCY 16 A komb.	3x2x0,14+2x0,5+4x0,14+4x0,22	26 AWG/ 3pr + 20 AWG/ 2c + 26 AWG/ 4c + 24 AWG/ 4c	494 028 71	9,4	78 kg	123 kg	1BD 51
<b>Servo Motor Cables / Servomotorleitungen</b>							
PSLCYJ	4x1,5	16 AWG/ 4c	494 052 63	8,1	78 kg	117 kg	1 BB 11
PSLCYJ	4x2,5	14 AWG/ 4c	494 053 63	9,8	121 kg	171 kg	1 BB 21
PSLCYJ	4x4	12 AWG/ 4c	494 054 63	11,3	189 kg	245 kg	1 BB 31
PSLCYJ	4x6	10 AWG/ 4c	494 055 63	13,1	290 kg	365 kg	1 BB 41
PSLCYJ	4x10	8 AWG/ 4c	494 056 63	*			1 BB 51
PSLCYJ	4x16	6 AWG/ 4c	494 057 63	*			1 BB 61
PSLCYJ	4x25	4 AWG/ 4c	494 058 63	*			1 BB 25
PSLCYJ	4x35	2 AWG/ 4c	494 059 63	*			1 BB 35
PSLCYJ	4x50	1 AWG/ 4c	494 060 63	*			1 BB 50
PSLCYJ	4x1,5+2x1,5/C	16 AWG/ 4c + 16 AWG/ 1pr	494 040 63	10,4	132 kg	186 kg	1 BA 11
PSLCYJ	4x2,5+2x1,5/C	14 AWG/ 4c + 16 AWG/ 1pr	494 041 63	12,0	171 kg	241 kg	1 BA 21
PSLCYJ	4x4+2x1,5/C	12 AWG/ 4c + 16 AWG/ 1pr	494 042 63	13,6	248 kg	333 kg	1 BA 31
PSLCYJ	4x6+2x1,5/C	10 AWG/ 4c + 16 AWG/ 1pr	494 043 63	15,6	338 kg	455 kg	1 BA 41
PSLCYJ	4x10+2x1,5/C	8 AWG/ 4c + 16 AWG/ 1pr	494 044 63	*			1 BA 51
PSLCYJ	4x16+2x1,5/C	6 AWG/ 4c + 16 AWG/ 1pr	494 045 63	*			1 BA 61
PSLCYJ	4x25+2x1,5/C	4 AWG/ 4c + 16 AWG/ 1pr	494 064 63	*			1 BA 25
PSLCYJ	4x35+2x1,5/C	2 AWG/ 4c + 16 AWG/ 1pr	494 065 63	*			1 BA 35
PSLCYJ	4x50+2x1,5/C	1 AWG/ 4c + 16 AWG/ 1pr	494 066 63	*			1 BA 50

\* cables on request

\* Leitungen auf Anfrage



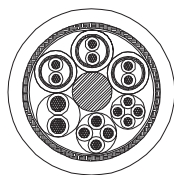

# PUR Feedback Cable

acc. SIEMENS Standard 6FX 8008-

## PUR Geberleitung

nach SIEMENS Standard 6FX 8008-

30 V

### Type Approval Certificates

UL 20236

### Applications

Feedback cables for use in energy chains up to 5 Mio. bending cycles according SFK 4

### Zulassungen

UL 20236

### Anwendung

Geberleitungen für die Verwendung in Schleppketten bis zu 5 Mio. Biegezyklen nach SFK 4 (Schlepp-Fähigkeits-Klasse)

**SFK** Schlepp-Fähigkeits-Klasse

1	2	3	4	5	6	7
---	---	---	---	---	---	---

### Design

- Conductor**  
tinned electrolyte stranded copper
- Insulation**  
special PP (9Y)

- Filler (optional)**  
special plastic film to cover all screens
- Screen**  
tinned copper braid
- Outer sheath**  
PUR (11Y)  
green – RAL 6018



### Aufbau

- Leiter**  
verzinnter Kupferleiter
- Isolierung**  
spezial PP (9Y)

- Füllelement**  
spezial Folie oder Vlies
- Schirm**  
Kupfergeflecht, verzinnt
- Außenmantel**  
PUR (11Y)  
grün – RAL 6018

### Marking

- cross section
- + approvals
- + date of production

### Core identification







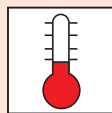

acc. SIEMENS specification

### Bedruckung

- Querschnitt
- + Zulassungen
- + Produktionsdatum

### Aderkennzeichnung

nach SIEMENS Spezifikation

							
-50 °C to +80 °C	yes	yes	yes	yes	yes	very good	yes

**PUR Feedback Cables** acc. SIEMENS Standard 6FX 8008-  
**PUR Geberleitungen** nach SIEMENS Standard 6FX 8008-

Type	Construction	AWG	Article no.	Outer diameter approx. mm	Copper weight kg/km	Total weight kg/km	SIEMENS ID
Typ	Aufbau	AWG	Artikelnummer	Außendurchmesser ca. mm	Kupferzahl kg/km	Gesamtgewicht kg/km	SIEMENS-Bezeichnung
SSLC11Y 8 P 0,18	8x2x0,18	25 AWG/ 8pr	494 833 71	7,8	54 kg	94 kg	1 BD 11
SSLC11Y 12 A komb.	4x2x0,34+4x0,5	22 AWG/ 4pr + 20 AWG/ 4c	494 826 71	8,9	71 kg	116 kg	1 BD 21
SSLC11Y 8 A komb.	3x2x0,14+2x0,5	26 AWG/ 3pr + 20 AWG/ 2c	494 827 71	8,7	64 kg	106 kg	1 BD 31
SSLC11Y 12 A komb.	3x2x0,14+2x0,5+4x0,14	26 AWG/ 3pr + 20 AWG/ 2c + 26 AWG/ 4c	494 829 71	8,9	61 kg	102 kg	1 BD 41
SSLC11Y 16 A komb.	3x2x0,14+2x0,5+ 4x0,14+4x0,22	26 AWG/ 3pr + 20 AWG/ 2c + 26 AWG/ 4c + 24 AWG/ 4c	494 828 71	9,4	78 kg	122 kg	1BD 51
SSLC11Y 4x2x0,18	4x2x0,18	25 AWG/ 4pr	494 831 71	6,4	32 kg	55 kg	1 BD 61
SSLC11Y 2x2x0,18	2x2x0,18	25 AWG/ 2pr	494 832 71	5,0	22 kg	39 kg	1 BD 71
SSLC11Y 12x0,22	12x0,22	24 AWG/ 12c	494 830 71	6,9	48 kg	75 kg	1 BD 81

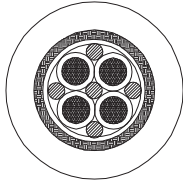

# PUR Servo Motor Cable without pair

acc. SIEMENS Standard 6FX 8008-

## PUR Servo Motorleitung ohne Paar

nach SIEMENS Standard 6FX 8008-

### Type Approval Certificates

UL/CSA 20234

### Applications

Servo motor cables for use in energy chains up to 5 Mio. bending cycles according SFK 4

600/1.000 V

### Zulassungen

UL/CSA 20234

### Anwendung

Servo Motorleitungen für die Verwendung in Schleppketten bis zu 5 Mio. Biegezyklen nach SFK 4 (Schlepp-Fähigkeits-Klasse)

SFK Schlepp-Fähigkeits-Klasse

1	2	3	4	5	6	7
---	---	---	---	---	---	---

### Design

- Conductor**  
bare stranded copper, extremely fine wires acc. to VDE 0295 class 6
- Insulation**  
TPM - PP modified (9Y)

- Filler (optional)**  
special plastic film to cover all screens
- Screen**  
braid of tinned copper
- Outer sheath**  
PUR (11Y)  
orange – RAL 2003

### Aufbau

- Leiter**  
Kupfer blank, feinstdrähtig (Klasse 6)
- Isolierung**  
TPM - PP modifiziert (9Y)

- Füllelement**  
spezial Folie oder Vlies
- Schirm**  
Kupfergeflecht, verzinkt
- Außenmantel**  
PUR (11Y)  
orange – RAL 2003



### Marking

cross section  
+ approvals  
+ date of production

### Core identification







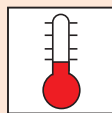

3 cores black, printed with numbers (u/v/www) + 1 core green-yellow

### Bedruckung

Querschnitt  
+ Zulassungen  
+ Produktionsdatum

### Aderkennzeichnung

3 Adern schwarz mit Bedruckung (u/v/www) + grün-gelb

							
-50 °C to +80 °C	yes	yes	yes	yes	yes	very good	yes

**PUR Servo Motor Cables without pair** acc. SIEMENS Standard 6FX 8008-  
**PUR Servo Motorleitungen ohne Paar** nach SIEMENS Standard 6FX 8008-

Type	Construction	AWG	Article no.	Outer diameter approx. mm	Copper weight kg/km	Total weight kg/km	SIEMENS ID
Typ	Aufbau	AWG	Artikelnummer	Außendurchmesser ca. mm	Kupferzahl kg/km	Gesamtgewicht kg/km	SIEMENS ID
PSLC11YJ	4x1,5	16 AWG/ 4c	494 852 6X	9,9	81 kg	145 kg	1 BB 11
PSLC11YJ	4x2,5	14 AWG/ 4c	494 853 6X	11,6	123 kg	204 kg	1 BB 21
PSLC11YJ	4x4	12 AWG/ 4c	494 854 6X	12,7	197 kg	285 kg	1 BB 31
PSLC11YJ	4x6	10 AWG/ 4c	494 855 6X	14,2	270 kg	362 kg	1 BB 41
PSLC11YJ	4x10	8 AWG/ 4c	494 856 6X	16,0	452 kg	549 kg	1 BB 51
PSLC11YJ	4x16	6 AWG/ 4c	494 857 6X	19,8	704 kg	847 kg	1 BB 61

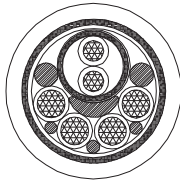

# PUR Servo Motor Cable with pair

acc. SIEMENS Standard 6FX 8008-

# PUR Servo Motorleitung mit Paar

nach SIEMENS Standard 6FX 8008-

**Type Approval Certificates**  
UL/CSA 20234

**Applications**  
Servo motor cables for use in energy chains up to 5 Mio. bending cycles according SFK 4

**600/1.000 V**

**Zulassungen**  
UL/CSA 20234

**Anwendung**  
Servo Motorleitungen für die Verwendung in Schleppketten bis zu 5 Mio. Biegezyklen nach SFK 4 (Schlepp-Fähigkeits-Klasse)

**SFK** Schlepp-Fähigkeits-Klasse

1	2	3	4	5	6	7
---	---	---	---	---	---	---

**Design**

- Conductor**  
bare stranded copper, extremely fine wires acc. to VDE 0295 class 6
- Insulation**  
TPM - PP modified (9Y)

- Filler (optional)**  
special plastic film to cover all screens
- Screen**  
braid of tinned copper
- Outer sheath**  
PUR (11Y)  
orange – RAL 2003



**Aufbau**

- Leiter**  
Kupfer blank, feinstdrähtig (Klasse 6)
- Isolierung**  
TPM - PP modifiziert (9Y)







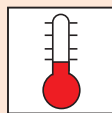

- Füllelement**  
spezial Folie oder Vlies
- Schirm**  
Kupfergeflecht, verzinkt
- Außenmantel**  
PUR (11Y)  
orange – RAL 2003

**Marking**  
cross section  
+ approvals  
+ date of production

**Core identification**  
3 cores black, printed with numbers (u/vv/www) + green-yellow + pair black/white

**Bedruckung**  
Querschnitt  
+ Zulassungen  
+ Produktionsdatum

**Aderkennzeichnung**  
3 Adern schwarz mit Bedruckung (u/vv/www) + grün-gelb + Paar schwarz/weiß

							
-50 °C to +80 °C	yes	yes	yes	yes	yes	very good	yes

**PUR Servo Motor Cables with pair** acc. SIEMENS Standard 6FX 8008-  
**PUR Servo Motorleitungen mit Paar** nach SIEMENS Standard 6FX 8008-

Type	Construction	AWG	Article no.	Outer diameter approx. mm	Copper weight kg/km	Total weight kg/km	SIEMENS ID
Typ	Aufbau	AWG	Artikelnummer	Außendurchmesser ca. mm	Kupferzahl kg/km	Gesamtgewicht kg/km	SIEMENS ID
PSLC11Y-J	4x1,5+2x1,5/C	16 AWG/ 4c + 16 AWG/ 1pr	494 840 6X	12,3	141 kg	226 kg	1 BA 11
PSLC11Y-J	4x2,5+2x1,5/C	14 AWG/ 4c + 16 AWG/ 1pr	494 841 6X	13,8	182 kg	278 kg	1 BA 21
PSLC11Y-J	4x4+2x1,5/C	12 AWG/ 4c + 16 AWG/ 1pr	494 842 6X	14,9	255 kg	367 kg	1 BA 31
PSLC11Y-J	4x6+2x1,5/C	10 AWG/ 4c + 16 AWG/ 1pr	494 843 6X	15,9	324 kg	439 kg	1 BA 41
PSLC11Y-J	4x10+2x1,5/C	8 AWG/ 4c + 16 AWG/ 1pr	494 844 6X	18,2	505 kg	637 kg	1 BA 51
PSLC11Y-J	4x16+2x1,5/C	6 AWG/ 4c + 16 AWG/ 1pr	494 845 6X	21,4	759 kg	939 kg	1 BA 61
PSLC11Y-J	4x25+2x1,5/C	4 AWG/ 4c + 16 AWG/ 1pr	494 864 6X	25,4	1.078 kg	1.317 kg	1 BA 25
PSLC11Y-J	4x35+2x1,5/C	2 AWG/ 4c + 16 AWG/ 1pr	494 865 6X	30,8	1.550 kg	1.894 kg	1 BA 35
PSLC11Y-J	4x50+2x1,5/C	1 AWG/ 4c + 16 AWG/ 1pr	494 866 6X	34,0	2.144 kg	2.553 kg	1 BA 50

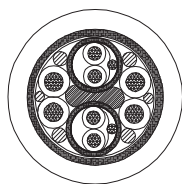

# PUR Servo Motor Cable

acc. INDRAMAT Standard

## PUR Servo Motorleitung

nach INDRAMAT Standard

**Type Approval Certificates**  
UL 21223

**Applications**  
Servo motor cables for use in energy chains up to 5 Mio. bending cycles according SFK 4

**600/1.000 V**

**Zulassungen**  
UL 21223

**Anwendung**  
Servo Motorleitungen für die Verwendung in Schleppketten bis zu 5 Mio. Biegezyklen nach SFK 4 (Schlepp-Fähigkeits-Klasse)



### Design

- Conductor**  
bare stranded copper, extremely fine wires acc. to VDE 0295 class 6
- Insulation**  
TPM - PP modified (9Y)

- Filler (optional)**  
special plastic film to cover all screens
- Screen**  
braid of tinned copper
- Outer sheath**  
PUR (11Y)  
orange – RAL 2003



### Aufbau

- Leiter**  
Kupfer blank, feinstdrähtig (Klasse 6)
- Isolierung**  
TPM - PP modifiziert (9Y)

- Füllelement**  
spezial Folie oder Vlies
- Schirm**  
Kupfergeflecht, verzinkt
- Außenmantel**  
PUR (11Y)  
orange – RAL 2003

### Marking

cross section  
+ approvals  
+ date of production

### Core identification







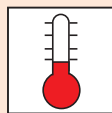

3 cores black, printed with numbers  
+ green-yellow + 2 pairs black printed with numbers

### Bedruckung

Querschnitt  
+ Zulassungen  
+ Produktionsdatum

### Aderkennzeichnung

3 Adern schwarz mit Ziffernbedruckung  
+ grün-gelb + 2 Paare schwarz mit Ziffernbedruckung

							
-50 °C to +80 °C	yes	yes	yes	yes	yes	very good	yes

**PUR Servo Motor Cables** acc. INDRAMAT Standard  
**PUR Servo Motorleitungen** nach INDRAMAT Standard

Type	Construction	AWG	Article no.	Outer diameter approx. mm	Copper weight kg/km	Total weight kg/km	INDRAMAT ID
Typ	Aufbau	AWG	Artikelnummer	Außendurchmesser ca. mm	Kupferzahl kg/km	Gesamtgewicht kg/km	INDRAMAT ID
PSLC11YJ	4x1 + 2x(2x0,75)StC	18 AWG/ 4c + 19 AWG/ 2pr	493 720 6X	11,0	140 kg	200 kg	IN 653
PSLC11YJ	4x1,5 + 2x(2x0,75)StC	16 AWG/ 4c + 19 AWG/ 2pr	493 721 6X	11,7	161 kg	231 kg	IN 650
PSLC11YJ	4x2,5 + 2x(2x0,75)StC	14 AWG/ 4c + 19 AWG/ 2pr	493 722 6X	12,9	201 kg	284 kg	IN 602
PSLC11YJ	4x2,5 + 2x(2x1,0)StC	14 AWG/ 4c + 18 AWG/ 2pr	493 762 6X	13,5	212 kg	301 kg	
PSLC11YJ	4x4 + 2x(2x1,0)StC	12 AWG/ 4c + 18 AWG/ 2pr	493 723 6X	15,2	288 kg	396 kg	IN 603
PSLC11YJ	4x4 + (2x1,5)StC + (2x1,0)StC	12 AWG/ 4c + 16 AWG/ 1pr + 18 AWG/ 1pr	493 773 6X	15,5	305 kg	416 kg	
PSLC11YJ	4x4 + 2x(2x1,5)StC	12 AWG/ 4c + 16 AWG/ 2pr	493 763 6X	15,8	327 kg	441 kg	
PSLC11YJ	4x6 + 2x(2x1,0)StC	10 AWG/ 4c + 18 AWG/ 2pr	493 724 6X	17,0	366 kg	497 kg	IN 604
PSLC11YJ	4x6 + (2x1,5)StC + (2x1,0)StC	10 AWG/ 4c + 16 AWG/ 1pr + 18 AWG/ 1pr	493 774 6X	17,9	386 kg	537 kg	
PSLC11YJ	4x6 + 2x(2x1,5)StC	10 AWG/ 4c + 16 AWG/ 2pr	493 764 6X	18,2	404 kg	555 kg	
PSLC11YJ	4x10 + 2x(2x1,0)StC	8 AWG/ 4c + 18 AWG/ 2pr	493 725 6X	20,0	545 kg	731 kg	IN 605
PSLC11YJ	4x10 + (2x1,5)StC + (2x1,0)StC	8 AWG/ 4c + 16 AWG/ 1pr + 18 AWG/ 1pr	493 775 6X	20,1	562 kg	750 kg	
PSLC11YJ	4x10 + 2x(2x1,5)StC	8 AWG/ 4c + 16 AWG/ 2pr	493 765 6X	20,2	579 kg	768 kg	
PSLC11YJ	4x16 + 2x(2x1,5)StC	6 AWG/ 4c + 16 AWG/ 2pr	493 726 6X	23,0	810 kg	1.052 kg	IN 606
PSLC11YJ	4x25 + 2x(2x1,5)StC	4 AWG/ 4c + 16 AWG/ 2pr	493 727 6X	28,4	1.192 kg	1.722 kg	IN 607
PSLC11YJ	4x35 + 2x(2x1,5)StC	2 AWG/ 4c + 16 AWG/ 2pr	493 728 6X	31,4	1.588 kg	2.177 kg	IN 667
PSLC11YJ	4x50 + 4x2,5 StC	1 AWG/ 4c + 14 AWG/ 4c	493 875 6X	38,0	2.083 kg	2.605 kg	IN 268
PSLC11YJ	4x0,75+(2x0,5) StC	19 AWG/ 4c + 20 AWG/ 1pr	493 876 6X	9,4	75 kg	129 kg	IN 670



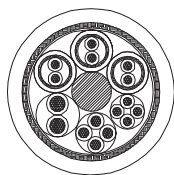

# PUR Control Cable

acc. INDRAMAT Standard

## PUR Steuerleitung

nach INDRAMAT Standard

300 V

### Type Approval Certificates

UL/CSA + VDE

### Applications

Control cables for use in energy chains up to 5 Mio. bending cycles according SFK 4

### Zulassungen

UL/CSA + VDE

### Anwendung

Steuerleitungen für die Verwendung in Schleppketten bis zu 5 Mio. Biegezyklen nach SFK 4 (Schlepp-Fähigkeits-Klasse)

SFK Schlepp-Fähigkeits-Klasse



### Design

- Conductor**  
tinned electrolyte stranded copper
- Insulation**  
special PP (9Y)

- Filler (optional)**  
special plastic film to cover all screens
- Screen**  
braid of tinned copper
- Outer sheath**  
PUR (11Y)  
orange – RAL 2003  
optional green – RAL 6018



### Aufbau

- Leiter**  
verzinnter Kupferleiter
- Isolierung**  
spezial PP (9Y)

- Füllelement**  
spezial Folie oder Vlies
- Schirm**  
Kupfergeflecht, verzinnt
- Außenmantel**  
PUR (11Y)  
orange – RAL 2003  
optional grün – RAL 6018

### Marking

cross section  
+ approvals  
+ date of production

### Core identification







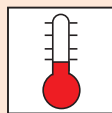

acc. INDRAMAT design

### Bedruckung

Querschnitt  
+ Zulassungen  
+ Produktionsdatum

### Aderkennzeichnung

nach INDRAMAT Aufbau

							
-50 °C to +80 °C	yes	yes	yes	yes	yes	very good	yes

**PUR Control Cables** acc. INDRAMAT Standard  
**PUR Steuerleitungen** nach INDRAMAT Standard

Type	Construction	AWG	Article no.	Outer diameter approx. mm	Copper weight kg/km	Total weight kg/km	INDRAMAT ID
Typ	Aufbau	AWG	Artikelnummer	Außendurchmesser ca. mm	Kupferzahl kg/km	Gesamtgewicht kg/km	INDRAMAT ID
SSL 9YSLC11Y 10Akomb.	4x2x0,25+2x1,0	24 AWG/ 4pr + 18 AWG/ 2c	493 870 6X	8,0	64 kg	97 kg	IN 209
SSL 9YSLC11Y 10Akomb.	4x2x0,25+2x0,5	24 AWG/ 4pr + 20 AWG/ 2c	493 890 6X	7,9	55 kg	79 kg	IN 448
SSLC11Y 34x0,25+2x0,5	34x0,25+2x0,5	24 AWG/ 34c + 20 AWG/ 1pr	493 880 6X	11,6	139 kg	216 kg	IN 271
SSLC11Y 16 A komb.	4x2x0,14+4x1,0+ (4x0,14)D	26 AWG/ 4pr + 18 AWG/ 4c + 26 AWG/ 4c	493 892 6X	9,5	89 kg	137 kg	IN 532
SSLC11Y 11 A komb.	3x0,25+3x(2x0,25)+ 2x1,0	24 AWG/ 3c + 24 AWG/ 3pr + 18 AWG/ 2c	493 899 6X	9,0	94 kg	125 kg	IN 280
SSLC11Y 2x2x0,25+2x0,5	2x2x0,25+2x0,5	24 AWG/ 2pr + 20 AWG/ 2c	493 877 6X	7,6	40 kg	82 kg	IN 750
SSLC11Y 9x0,5	9x0,5	20 AWG/ 9c	493 869 6X	8,7	80 kg	106 kg	IN 208

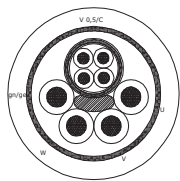

# PUR Linear Motor Cable with inner jacket

## PUR Linear Motorleitung mit Innenmantel

**Type Approval Certificates**  
UL/CSA 20234

**Applications**  
Linear Motor cables for use in energy chains up to 5 Mio. bending cycles according SFK 6

**600/1.000 V**

**Zulassungen**  
UL/CSA 20234

**Anwendung**  
Linear Motorleitungen für die Verwendung in Schleppketten bis zu 5 Mio. Biegezyklen nach SFK 6 (Schlepp-Fähigkeits-Klasse)

**SFK** Schlepp-Fähigkeits-Klasse

1	2	3	4	5	6	7
---	---	---	---	---	---	---

### Design

- Conductor**  
bare stranded copper, extremely fine wires acc. to VDE 0295 class 6
- Insulation**  
TPM - PP modified (9Y)

- Inner sheath**  
PUR (11Y)
- Screen**  
tinned copper braid
- Outer sheath**  
PUR (11Y)  
orange – RAL 2003

### Aufbau

- Leiter**  
Kupfer blank, feinstdrähtig (Klasse 6)
- Isolierung**  
TPM - PP modifiziert (9Y)

- Innenmantel**  
PUR (11Y)
- Schirm**  
Kupfergeflecht, verzinkt
- Außenmantel**  
PUR (11Y)  
orange – RAL 2003



### Marking

cross section  
+ approvals  
+ date of production

### Core identification







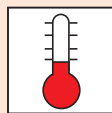

3 cores black, printed with numbers (u/vv/www) + 1 core green-yellow + 1 quad (black/white/red/yellow)

### Bedruckung

Querschnitt  
+ Zulassungen  
+ Produktionsdatum

### Aderkennzeichnung

3 Adern schwarz mit Ziffernbedruckung (u/vv/www) + grün-gelb + 1 Vierer (schwarz/weiß/rot/gelb)

							
-50 °C to +80 °C	yes	yes	yes	yes	yes	very good	yes

**PUR Linear Motor Cables with inner jacket**  
**PUR Linear Motorleitungen mit Innenmantel**

Type	Construction	AWG	Article no.	Outer diameter approx. mm	Copper weight kg/km	Total weight kg/km
Typ	Aufbau	AWG	Artikelnummer	Außendurchmesser ca. mm	Kupferzahl kg/km	Gesamtgewicht kg/km
LMSL11YC11YJ	4x1,5 +1V0,5	16 AWG/ 4c + 20 AWG/ 1quad	494 707 6X	12,0	131 kg	238 kg
LMSL11YC11YJ	4x2,5 +1V0,5	14 AWG/ 4c + 16 AWG/ 1quad	494 708 6X	13,5	174 kg	289 kg
LMSL11YC11YJ	4x4 +1V0,5	12 AWG/ 4c + 16 AWG/ 1quad	494 709 6X	15,3	256 kg	409 kg
LMSL11YC11YJ	4x6 +1V0,5	10 AWG/ 4c + 16 AWG/ 1quad	494 710 6X	16,9	335 kg	520 kg
LMSL11YC11YJ	4x10 +1V0,5	8 AWG/ 4c + 16 AWG/ 1quad	494 711 6X	20,2	508 kg	715 kg
LMSL11YC11YJ	4x16 +1V0,5	6 AWG/ 4c + 16 AWG/ 1quad	494 712 6X	22,3	749 kg	1.009 kg

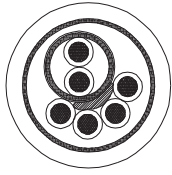

# PUR Servo Motor Cable with inner jacket

## PUR Servo Motorleitung mit Innenmantel

### Type Approval Certificates

UL/CSA 20234

### Applications

Servo Motor cables for use in energy chains up to 5 Mio. bending cycles according SFK 6

600/1.000 V

### Zulassungen

UL/CSA 20234

### Anwendung

Servo Motorleitungen für die Verwendung in Schleppketten bis zu 5 Mio. Biegezyklen nach SFK 6 (Schlepp-Fähigkeits-Klasse)

**SFK** Schlepp-Fähigkeits-Klasse

1	2	3	4	5	6	7
---	---	---	---	---	---	---

### Design

- Conductor**  
bare stranded copper, extremely fine wires acc. to VDE 0295 class 6
- Insulation**  
TPM - PP modified (9Y)

- Inner sheath**  
PUR (11Y)
- Screen**  
tinned copper braid
- Outer sheath**  
PUR (11Y)  
orange – RAL 2003

### Aufbau

- Leiter**  
Kupfer blank, feinstdrähtig (Klasse 6)
- Isolierung**  
TPM - PP modifiziert (9Y)

- Innenmantel**  
PUR (11Y)
- Schirm**  
Kupfergeflecht, verzinkt
- Außenmantel**  
PUR (11Y)  
orange – RAL 2003



### Marking

cross section  
+ approvals  
+ date of production

### Core identification







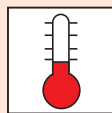

3 cores black, printed with numbers (u/vv/www) + green-yellow + 1 pair white/red

### Bedruckung

Querschnitt  
+ Zulassungen  
+ Produktionsdatum

### Aderkennzeichnung

3 Adern schwarz mit Ziffernbedruckung (u/vv/www) + grün-gelb + 1 Paar weiß/rot

							
-50 °C to +80 °C	yes	yes	yes	yes	yes	very good	yes

**PUR Servo Motor Cables with inner jacket**  
**PUR Servo Motorleitungen mit Innenmantel**

Type	Construction	AWG	Article no.	Outer diameter approx. mm	Copper weight kg/km	Total weight kg/km
Typ	Aufbau	AWG	Artikelnummer	Außendurchmesser ca. mm	Kuperzahl kg/km	Gesamtgewicht kg/km
PSL18YC11YJ	4x1,5+2x1,5/C	16 AWG/ 4c + 16 AWG/ 1pr	494 950 6X	12,5	140 kg	221 kg
PSL18YC11YJ	4x2,5+2x1,5/C	14 AWG/ 4c + 16 AWG/ 1pr	494 951 6X	14,1	182 kg	307 kg
PSL18YC11YJ	4x4+2x1,5/C	12 AWG/ 4c + 16 AWG/ 1pr	494 952 6X	15,6	270 kg	411 kg
PSL18YC11YJ	4x6+2x1,5/C	10 AWG/ 4c + 16 AWG/ 1pr	494 953 6X	17,3	351 kg	527 kg
PSL18YC11YJ	4x10+2x1,5/C	8 AWG/ 4c + 16 AWG/ 1pr	494 954 6X	19,6	516 kg	712 kg
PSL18YC11YJ	4x16+2x1,5/C	6 AWG/ 4c + 16 AWG/ 1pr	494 955 6X	24,0	769 kg	1.096 kg
PSL18YC11YJ	4x25+2x1,5/C	4 AWG/ 4c + 16 AWG/ 1pr	494 956 6X	28,0	1.150 kg	1.615 kg
PSL18YC11YJ	4x1,5	16 AWG/ 4c	494 970 6X	10,1	83 kg	160 kg
PSL18YC11YJ	4x2,5	14 AWG/ 4c	494 971 6X	11,7	129 kg	221 kg
PSL18YC11YJ	4x4	12 AWG/ 4c	494 972 6X	13,3	202 kg	321 kg
PSL18YC11YJ	4x6	10 AWG/ 4c	494 973 6X	15,3	270 kg	412 kg
PSL18YC11YJ	4x10	8 AWG/ 4c	494 974 6X	17,9	455 kg	628 kg
PSL18YC11YJ	4x16	6 AWG/ 4c	494 975 6X	21,8	715 kg	978 kg
PSL18YC11YJ	4x25	4 AWG/ 4c	494 976 6X	26,4	1.033 kg	1.381 kg

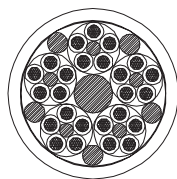

# Torsion Cable for 3 dimensional motion

## Torsionsleitung für 3-dimensionale Bewegung

### Type Approval Certificates

UL/CSA  
on demand

### Zulassungen

UL/CSA  
auf Anfrage

### Applications

Cables for torsion application  
+/- 180 °/m up to +/- 540 °/m

### Anwendung

Leitungen für Torsionsapplikationen  
+/- 180 °/m bis zu +/- 540 °/m

### Design

1. **Conductor**  
bare copper, very fine wires,  
VDE 0295 class 6
2. **Insulation**  
special insulation, halogen free

### Aufbau

1. **Leiter**  
Kupfer blank Klasse 6
2. **Isolierung**  
Spezial-Isolierung, halogenfrei

3. **Filler/Taping**  
acc. requirement
4. **Screen (optional)**  
spiralization of tinned copper  
optional special screen construction
5. **Outer sheath**  
PUR (11Y)

3. **Füllelement/Bewicklung**  
entsprechend der Anforderung
4. **Schirm (optional)**  
verzinnte Kupferumseilung bzw.  
Spezierschirmkonstruktion
5. **Außenmantel**  
PUR (11Y)



### Marking

cross section  
+ approvals  
+ date of production

### Bedruckung







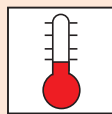

Querschnitt  
+ Zulassungen  
+ Produktionsdatum

### Core identification

black cores with white numbers +  
green/yellow (optional)

### Aderkennzeichnung

schwarze Adern mit weißem  
Ziffernaufdruck + grün/gelb (optional)

							
-50 °C to +80 °C	yes	yes	yes	yes	yes	very good	yes

## Torsion Cable for 3 dimensional motion Torsionsleitung für 3-dimensionale Bewegung

Type	Construction	Outer diameter approx. mm	Copper weight kg/km	Total weight kg/km
Typ	Aufbau	Außendurchmesser ca. mm	Kupferzahl kg/km	Gesamtgewicht kg/km
TL11YJ	7x0,25	6,6	26 kg	60 kg
TL11YJ	25x0,25	11,6	80 kg	190 kg
TL11YJ	18x0,5	12,1	85 kg	161 kg
TL11YJ	25x0,5	13,2	120 kg	220 kg
TL11YJ	4x0,75	6,0	30 kg	59 kg
TL11YJ	14x0,75	12,0	102 kg	181 kg
TL11Y	2x1,0	5,5	19 kg	42 kg
TL11YJ	3x1,0	5,8	29 kg	56 kg
TL11YJ	4x1,0	6,4	39 kg	65 kg
TL11YJ	7x1,0	8,7	66 kg	103 kg
TL11YJ	12x1,0	10,9	115 kg	173 kg
TL11YJ	16x1,0+(2x1,0)/D	15,0	181 kg	315 kg
TL11YJ	18x1,0	14,6	167 kg	291 kg
TL11YJ	23x1,0+(2x1,0)/D	17,6	240 kg	395 kg
TL11YJ	25x1,0	16,6	229 kg	350 kg
TL11YJ	34x1,0	20,1	317 kg	522 kg
TL11YJ	41x1,0	21,7	382 kg	620 kg
TL11YJ	18x1,5	16,7	258 kg	400 kg
TL11YJ	25x1,5	20,9	361 kg	605 kg
TL11YJ	3x2,5	8,9	69 kg	125 kg
TL11YJ	4x2,5	9,7	92 kg	160 kg
TL11YJ	3x4	9,9	113 kg	170 kg
TL11YJ	3x6	11,3	167 kg	225 kg
TL11YJ	3x10	14,2	293 kg	380 kg
TL11YJ	3x16	16,6	465 kg	605 kg
TL11YJ	3x25	22,3	675 kg	919 kg
TL11YJ	3x35	24,9	1.002 kg	1.263 kg
<b>screened (spiralization) / geschirmt (Umseilung)</b>				
TLD11YJ	12x0,14 D	7,8	40 kg	90 kg
TLD11YJ	3x2x0,14 D	5,7	18 kg	32 kg
TLD11YJ	25x0,25 D	12,0	95 kg	230 kg
TLD11Y	4x0,34 D	5,4	23 kg	42 kg
TLD11Y	5x2x0,34 D	8,7	52 kg	93 kg
TLD11YJ	12x1,5 D	15,9	235 kg	380 kg
TLD11YJ	18x1,5 D	19,2	360 kg	560 kg



# Installation Instructions

## Installation of the cables in the drag chain

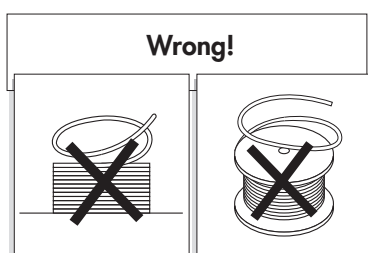
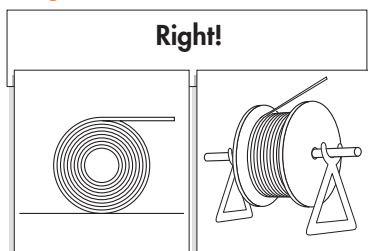

The removal of the cables must be without twists, i.e. the cables must be reeled off. They must never be pulled in loops over the flange of the drum. A balanced filling of the webs guarantees that the position of the cables remains unchanged during operation.

Do not install cables of different sheath materials without using a separation web.

The cables should be installed as symmetrically as possible depending on their weights and measurements. This is also true for the outer diameters. Cables which highly differ in outer diameter should be separated by webs.

The cables must not be installed in a fixed construction in the chain, but they must be mobile. In particular in the area of the bending radii the cables must move freely. The indicated minimum bending radii must be considered the absolute minimum value.

## Fastening of the cable in the drag chain

Both ends of the cable must be fixed in a dead zone in an appropriate distance to the ends of the mobile parts (approx. 30 x diameter). At least in the area of the mobile parts of the drag chain the cables must be provided with a traction relief.

## Cable installation in engines

The cables must not touch the surface of the engine.

## Minimum admissible bending radii

12 x outer diameter of the cable.  
Smaller bending radii are possible at a reduced life.

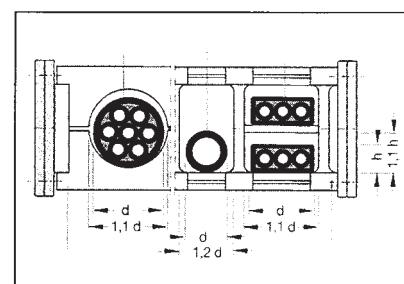
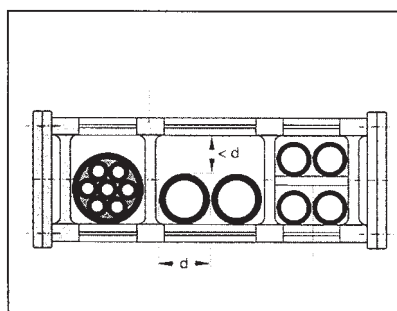

## Hinweise zur Installation

### Installation der Kabel in der Schleppkette

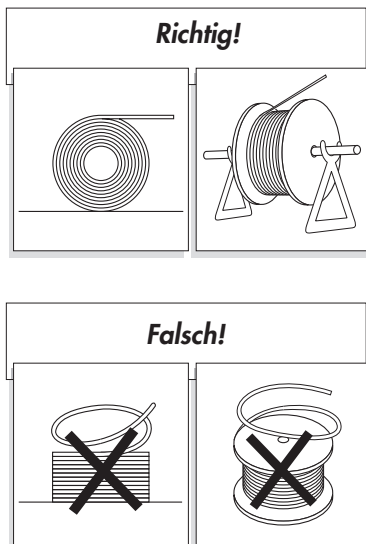

Die Kabel müssen gerade und unverdreht von der Kabelrolle abgewickelt, d.h. abgerollt werden. Niemals das Kabel in Schleifen seitlich über die Kabeltrommel abziehen. Stellen Sie mittels gleichmäßig angebrachter Kabelstegen sicher, dass die Position der Kabel im Betrieb unverändert bleibt.

Kabel mit unterschiedlichen Mantelmaterialien dürfen nur mit einem Trennsteg nebeneinander installiert werden.

Die Kabel müssen entsprechend ihrem Gewicht und ihren Abmessungen so symmetrisch wie möglich installiert werden. Dies gilt auch für die Außendurchmesser der Kabel. Kabel mit stark unterschiedlichen Außendurchmessern müssen über Stege voneinander getrennt werden. Die Kabel dürfen nicht in einer festen Konstruktion in einer Kette installiert werden, sondern müssen beweglich sein. Insbesondere im Bereich der Biegestellen müssen sich die Kabel frei bewegen können. Der angegebene Biegeradius ist als absoluter Mindestwert zu verstehen.

### Befestigung der Kabel in der Schleppkette

Beide Kabelenden müssen in einer Totzone in ausreichendem Abstand zu den Enden der beweglichen Teile (ca. 30facher Durchmesser) befestigt werden. Mindestens im Bereich der beweglichen Teile der Schleppkette ist an den Kabeln eine Zugentlastung vorzusehen.

### Installation der Kabel in Motoren

Die Kabel dürfen die Oberfläche des Motors nicht berühren.

### Minimal zulässiger Biegeradius

12facher Außendurchmesser des Kabels. Kleinere Biegeradien sind unter Verringerung der Nutzungsdauer möglich.

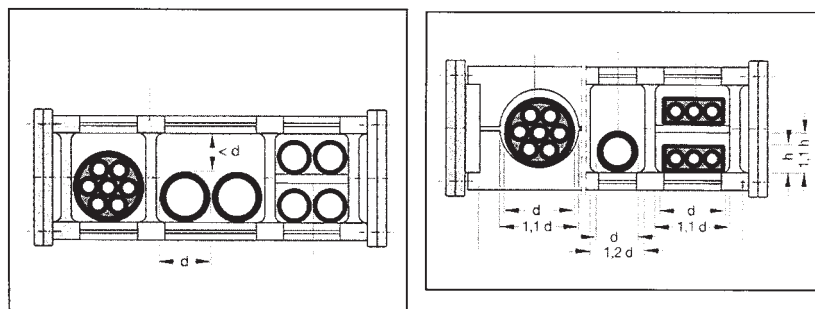

# Installation Instructions

## Pulling force

max. 50 N/mm<sup>2</sup> conductor cross section for fixed installation,  
max. 20 N/mm<sup>2</sup> conductor cross section for flexible horizontal installation

## Use in the drag chain

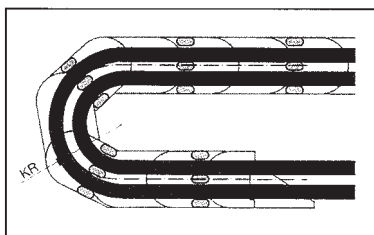

Standard version (single sheath construction with/without screen braid)

- minimum admissible bending radius: 12 x D
- maximum admissible acceleration: 5 m/sec.<sup>2\*</sup>
- maximum admissible speed: 100 m/min (180 m/min)\*\*
- guaranteed bendings (at radii ≥ 12xD): min. 10 Mio\*

D..... Conductor cross section (mm)  
 \* for cables with cross section > 16 mm<sup>2</sup> reduced requirements  
<sup>2</sup> (acceleration ≤ 1 m/sec<sup>2</sup>, ≥ million bendings)  
 \*\* for cables ≤ 6 mm<sup>2</sup> conductor cross section  
 + The installation instructions of the drag chain manufacturer of must be observed in addition.

- maximum admissible operating way: 5 m
- alternating bendings not admissible
- Torsion is not admissible for cables with overall screen (torsion for a maximum ± 30°/m are admissible)

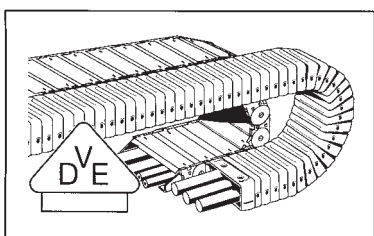

For deviating (higher) requirements, like

- smaller bending radii
- higher horizontal / vertical displacements
- higher velocities / acceleration
- alternating bendings
- torsion et cetera

there are special constructions available on customers request.

## Hinweise zur Installation

### Zugbelastung

max. 50 N/mm<sup>2</sup> Leiterquerschnitt bei fester Installation,  
max. 20 N/mm<sup>2</sup> Leiterquerschnitt bei beweglicher horizontaler Installation

### Einsatz in der Schleppkette

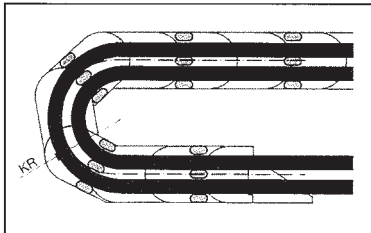

Herkömmlicher Aufbau (Kabelmantel mit/ohne Geflechtschirm)

- Minimal zulässiger Biegeradius: 12 x D
- Maximal zulässige Beschleunigung: 5 m/sec.<sup>2</sup>\*
- maximal zulässige Geschwindigkeit: 100 m/min (180 m/min)\*\*
- Garantierte Biegefestigkeit  
(bei Radius ≥ 12xD): min. 10 Mio. Biegebeanspruchungen\*

D..... Außendurchmesser (mm)

- \* Bei Kabeln mit Querschnitt > 16 mm<sup>2</sup> reduzierte Anforderungen  
(Beschleunigung ≤ 1 m/sec<sup>2</sup>, ≥ million Biegebelastungen)
- <sup>2</sup> Bei Kabeln mit ≤ 6 mm<sup>2</sup> Leiterquerschnitt
- \*\* Die Installationshinweise des Herstellers der Energieübertragungsketten sind zusätzlich zu beachten.

- Maximal zulässige horizontale Bewegung: 5 m
- Biegungen in wechselnde Richtungen nicht zulässig
- Torsion nicht zulässig bei Kabeln mit Außenschirm  
(Torsion bis zu einem Maximum von ± 30°/m zulässig)

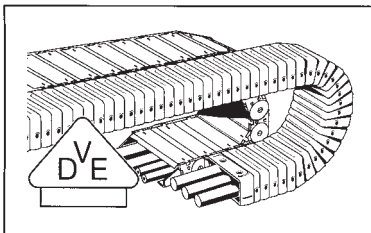

Bei abweichenden (höheren) Anforderungen, wie

- kleinere Biegeradien
- größeren horizontalen / vertikalen Bewegungen
- höheren Geschwindigkeiten / Beschleunigungen
- alternierenden Biegerichtungen
- Torsion usw.

werden auf Kundenwunsch Spezialkonstruktionen angeboten.

### Assets of the robot trailing cables

The use of the robot trailing cables is particularly recommended for the continually high bending stress in the machine tool equipment and industrial robots. They are constructed to withstand more than 10 million bendings at a bending radius of 12 x outer diameter attained at displacement velocities of 2 to 3 m/sec and accelerations of up to 5 m/sec<sup>2</sup>. Special constructions and selected appropriate materials guarantee that the high requirements of the robot trailing cables are met.

Compared to the traditional PVC cables the robot trailing cables made by NEXANS have the following assets:

The special PP, TPM and TPE insulation of the cores is unique for the excellent gliding properties of the cores even at high operating temperatures, thus guaranteeing an increased life in spite of high mechanical stress. This insulation is neither affected by crushings (contractions) nor by plasticizers respectively bleeding which may result in a brittle insulation. Apart from good heat resistance, those insulation

materials, are extremely flexible when exposed to extremely low temperatures and embattlement and unusual rigidity do not occur even at temperatures as low as – 50 °C. The extraordinary quality of the mechanical properties like tensile high stress, high notch and abrasion resistance protect the conductor against permanent stress.

The electromagnetic compatibility (EMC) is guaranteed by the screen construction with an optimised angle of inclination.

The outer sheath made of a special polyurethane with its known resistance to low temperatures, oils, greases, lubricants and cooling agents is an ideal complement to the good properties of the insulation.

All included, this special cable concept is the result of a long row of complicated tests and it has meanwhile proved to be successful on the market. Important users like Baumüller, Bosch, Fanuc, Heidenhain, Indramat, Moog or Siemens are among our customers.

## Vorteile der Roboter-Schleppkabel

Der Einsatz von Roboter-Schleppkabeln empfiehlt sich besonders bei den kontinuierlich hohen Biegebeanspruchungen in Maschinenwerkzeugen und Industrierobotern. Diese Kabel sind so aufgebaut, dass sie mehr als 10 Millionen Biegebelastungen mit einem Biegeradius des 12fachen Außendurchmessers bei Bewegungsgeschwindigkeiten von 2 – 3 m/sek. und Beschleunigungen von bis zu 5 m/sek.<sup>2</sup> standhalten.

Spezialaufbauten und ausgewählte Materialien sorgen dafür, dass die hohen Anforderungen an Roboter-Schleppkabel garantiert erfüllt werden.

Gegenüber herkömmlichen PVC-Kablen bieten die Roboter-Schleppkabel von NEXANS folgende Vorteile:

Die spezielle PP-, TPM- und TPE-Isolierung der Adern bietet ein einzigartiges Gleitverhalten selbst bei hohen Betriebstemperaturen und sichert damit eine hohe Nutzungslebensdauer der Kabel selbst bei starker mechanischer Beanspruchung. Diese Isolierung wird weder durch Stauchen (Quetschen) noch durch Weichmacher bzw. Ausblutungen brüchig. Neben ihrer hohen Wärmefestigkeit

bieten diese Isoliermaterialien extreme Biegsamkeit auch bei sehr niedrigen Temperaturen. Selbst bei Temperaturen von  $-50^{\circ}\text{C}$  treten keine Versteifungen oder übermäßige Starre auf. Die herausragend guten mechanischen Eigenschaften wie hohe Zugfestigkeit, Kerbschlagfestigkeit und Abriebfestigkeit schützen den Leiter auch bei dauerhaft hoher Beanspruchung.

Die elektromagnetische Verträglichkeit (EMV) wird durch den Schirmaufbau mit optimiertem Winkel sichergestellt.

Der äußere Kabelmantel aus Spezial-Polyurethan mit bewährter hoher Beständigkeit gegenüber niedrigen Temperaturen, Ölen, Fetten, Schmier- und Kühlmitteln ergänzt die herausragenden Eigenschaften der Isolierung in optimaler Weise.

Das gesamte Spezialkabel-Konzept ist das Ergebnis einer langen Reihe umfangreicher Tests und hat sich inzwischen erfolgreich am Markt bewährt. Zu den Anwendern unserer speziellen Roboter-Schleppkabel zählen so wichtige Kunden wie Baumüller, Bosch, Fanuc, Heidenhain, Indramat, Moog und Siemens.

### Special cables for drag chains

More and more manufacturing automates and transportation systems are equipped with drag chains which include the necessary connecting cables. Cables with special construction are absolutely necessary to guarantee the long-term and safe transmission of energy and data. These cables must meet the tough requirements like bending stress

due to extended displacement and high displacement velocities.

Our robot trailing cables with PP, TPM and TPE insulation and TPU sheath particularly meet the high electrical and mechanical requirements.

### Spezielle Schleppkettenleitungen

*Immer mehr Produktionsautomaten und Fördersysteme werden heute mit Schleppketten ausgestattet, die die erforderlichen Anschlusskabel enthalten. Um die langfristige Zuverlässigkeit und Sicherheit der Strom- und Datenübertragung zu gewährleisten, sind hier Kabel mit einem speziellen Aufbau gefordert. Diese müssen den härtesten Bean-*

*spruchungen, wie Biegebelastungen durch lange Bewegungstrecken und hohe Bewegungsgeschwindigkeiten, standhalten.*

*Unsere Roboter-Schleppketten mit PP-, TPM- und TPE-Isolierung und TPU-Ummantelung werden den hohen elektrischen und mechanischen Anforderungen umfassend gerecht.*

## Content / Inhalt

### Page / Seite

<b>BUS cables</b> <b>BUS Leitungen</b>	General Information/ <i>Allgemeine Information</i> Why BUS Systems? / <i>Warum BUS Systeme?</i>	50 - 52
	<b>BUS Types and Sensor BUS / <i>BUS Types und Sensor BUS</i></b>	
	AS-Interface Bus	53 - 54
	Interbus	55 - 56
	Profibus Cable	57 - 60
	Hybrid Bus Cable	61 - 62
	Profibus PA	63 - 64
	Industrial Ethernet/Profinet Cable	65 - 66
	Can-Bus Cable	67 - 68
	DeviceNet	69 - 70
<b>Sensor cables</b> <b>Sensorleitungen</b>	Sensor Cable / <i>Sensorleitungen</i>	71 - 72
<b>Overview</b> <b>Übersicht</b>	Technical Data BUS Cables / <i>Technische Daten Busleitungen</i>	73 - 74



## Why Bus Systems?

Since the beginning of the 80s Bus Systems are well known through the EDP (electronic data processing). Because of the high hardware costs the first typical structures were mainframes which controlled the whole data handling and organised several terminals. For this structure (so called "Star Topologies") there is a need for a connection between every work station and the mainframe which means a tremendous effort of cabling.

Due to the decreasing hardware costs the terminals were replaced through PCs and workstations which were able to organize the main part of data processing by themselves. Now the mainframes could be replaced through less efficiently

but cheaper mini Computers or workstations. The communication between the single computers was reconverted to Bus systems (Ethernet, Thin-Ethernet, Arc-Net) or "ring topologies" (Token Ring etc.), which allows a simple and flexible Cabling above always one cable. The same effect was observed in/realised for the machinery and installation engineering.

The central configuration of the electrical shift units, control technique and in-/output-devices in switchboards means a high effort of cabling and restricted flexibility in kind of any enhancements or necessary accommodations. Above all the high number of contacts and conductors means a waste of time in trouble shooting by implementing and service. An advantage could be the decentralisation of the electric

components, e.g. the transfer of the control- and shift-units directly to the periphery of the machine or construction. Instead of a thick stranded cable there is just a thin cable remaining.

Furthermore the networking of systems gains an increase of interest, especially the decentral distributed intelligence in the Industry- Building- Environmentor Traffic-Automation. Here Bus Systems are used as an communication medium for sectorred actuators, sensors and steering in the automation technic and all over there where electronic modules has to be connected without a big effort of cabling.

Only one cable connects all components.

## Warum BUS Systeme?

Seit Beginn der 80er Jahre werden sogenannte BUS Systeme für die elektronische Datenverarbeitung an Maschinen und Anlagen verwendet. Aufgrund der hohen Hardwarekosten waren die ersten Strukturen Systeme, die das gesamte Datenhandling kontrollierten und verschiedene Anschlussgeräte ansteuerten. Für diese Struktur (sogenannte „Stern Topologie“) wurde eine Verbindung zwischen jedem Arbeitsplatz und dem Großrechner notwendig, was einen enormen Verkabelungsaufwand bedeutete.

Aufgrund der sinkenden Hardwarekosten wurden die Anschlussgeräte durch PCs und Workstations ersetzt, die fähig waren, den Hauptbestandteil der Datenverarbeitung selbst zu organisieren. Dadurch konnten die Großrechner durch weniger leistungsfähige jedoch günstigere

Minicomputer oder Workstations ersetzt werden. Die Kommunikation zwischen den einzelnen Geräten wurde auf ein BUS System umgestellt (Ethernet, Thin-Ethernet, Arc-Net) oder „Ring- Topologien“ (Token Ring usw.), die eine leichtere und flexiblere Verkabelung über nur ein Kabel ermöglichen. Dieser Effekt wurde auch bei der Maschinen und Installationsengineering beobachtet.

Die zentrale Konfiguration in elektrischen Schaltzentralen, Kontrolltechnik und Ein-/Ausgabe-geräten in Schaltschränken bedeutet hohen Verkabelungsaufwand und eingeschränkte Flexibilität, wenn es darum geht Weiterentwicklungen oder notwendige Erweiterungen vorzunehmen.

Über allem steht die hohe Anzahl an Kontakten und Leitern, die vor allem bei der Fehlersuche während der Installation und Wartung

eine Verschwendung von Zeit bedeutet. Ein Vorteil könnte die Dezentralisierung der elektrischen Komponenten sein, zum Beispiel der Transfer der Kontroll- und Schalteinheiten zur Peripherie der Maschinen und Anlagen. Anstelle eines dicken Kabelstrangs bleibt dann nur ein dünnes Kabel bestehen. Weiterhin führt die Vernetzung von Systemen zu steigendem Interesse, vor allem bei dezentralen verteilten Steuerungen in Industrie - Gebäude - Umgebung - Verkehr - Automation. Hier werden BUS-Systeme als Kommunikationsmedium für verteilte Aktoren, Sensoren und Steuerungen in der Automationstechnik genutzt und überall elektronische Komponenten, die ohne großen Verkabelungsaufwand verbunden werden müssen.

Nur ein Buskabel verbindet alle Komponenten. Dieses wird über die Adressierung erreicht.

The summarized advantages of Bus Systems are as follows:

- Less wiring/cabling
- Small space in switchboards
- More transparency
- Faster diagnose
- Better availability
- Higher safety

All these pros leads to relevant cost advantages.

The different requirements to the bussystem, the variety of technical solutions but also corporate policy leads to a variety of bussystems without a single standard.

*Die Vorteile von Bus Systemen lassen sich wie folgt zusammenfassen:*

- geringer Verkabelungsaufwand
- weniger Raumbedarf in Kabelschränken
- höhere Transparenz
- schnellere Diagnosemöglichkeiten
- bessere Verfügbarkeit
- höhere Sicherheit

*All diese Vorteile führen zu Kostenersparnissen.*

*Die verschiedenen Anforderungen an BUS Systeme, die Vielfalt technischer Lösungsansätze sowie Unternehmenspolitik führen zu*

### Field Bus

Field bus is the generic name for all bussystems which are used for the metrology, steering and controlling engineering.

These are:

- CAN
- Profibus
- Interbus
- ASI Bus

According to the DIN (German institute for standardisation) standard a field bus in general should transmit a small volume of data in fast time series on a digital

*verschiedensten BUS-Systemen ohne Einzelstandard*

### Feldbusanlagen

*Feldbus ist der allgemeine Name für alle Bus-Systeme die für die Messtechnik, Maschinenbau und Steuerungstechnik verwendet werden.*

- CAN
- Profibus
- Interbus
- ASI Bus

*Gemäß DIN Standard (Deutsches Institut für Norm) soll ein Feldbus im allgemeinen ein begrenztes Datenvolumen in schnellen*

compare between sensors/actuators and steering. As the requirements to the bus system depends on the level of automation, there is no field bus which can solve all tasks optimal together.

Following table should show a short overview of the most important features of the three first called bus systems:

*Zeitabständen während eines digitalen Abgleichs zwischen Sensor/Aktor und Steuerung transportieren. Beruhen die Anforderungen an ein BUS System auf dem Automationslevel, gibt es keinen Feldbus der alle Aufgaben optimal lösen kann.*

*Folgende Übersicht zeigt einen kurzen Überblick über die wichtigsten Eigenschaften der drei erstgenannten BUS Systeme:*

	Highest BPS <i>Höchste Datenrate</i>	Dimension <i>Größe</i>	Max. number of participants <i>max. Anzahl der Teilnehmer</i>	Standardisation <i>Standard</i>
<b>CAN Bus</b>	1 Mbit/s to 40 m	1 km at 50 Kbit/s	64 (128)	ISO 11898
<b>Profibus</b>	500 Kbit/s to 200 m	1200 m at 93 Kbit/s	256	ISO 19245
<b>Interbus</b>	500 Kbit/s to 40 m	12,8 km at 400 m Segments	256	ISO 19258
<b>Profinet/ Industrial Ethernet</b>	100 Mbit/s to	Per 100 m Segments	unlimited / <i>unbegrenzt</i>	IEC 11801

### Example Profibus

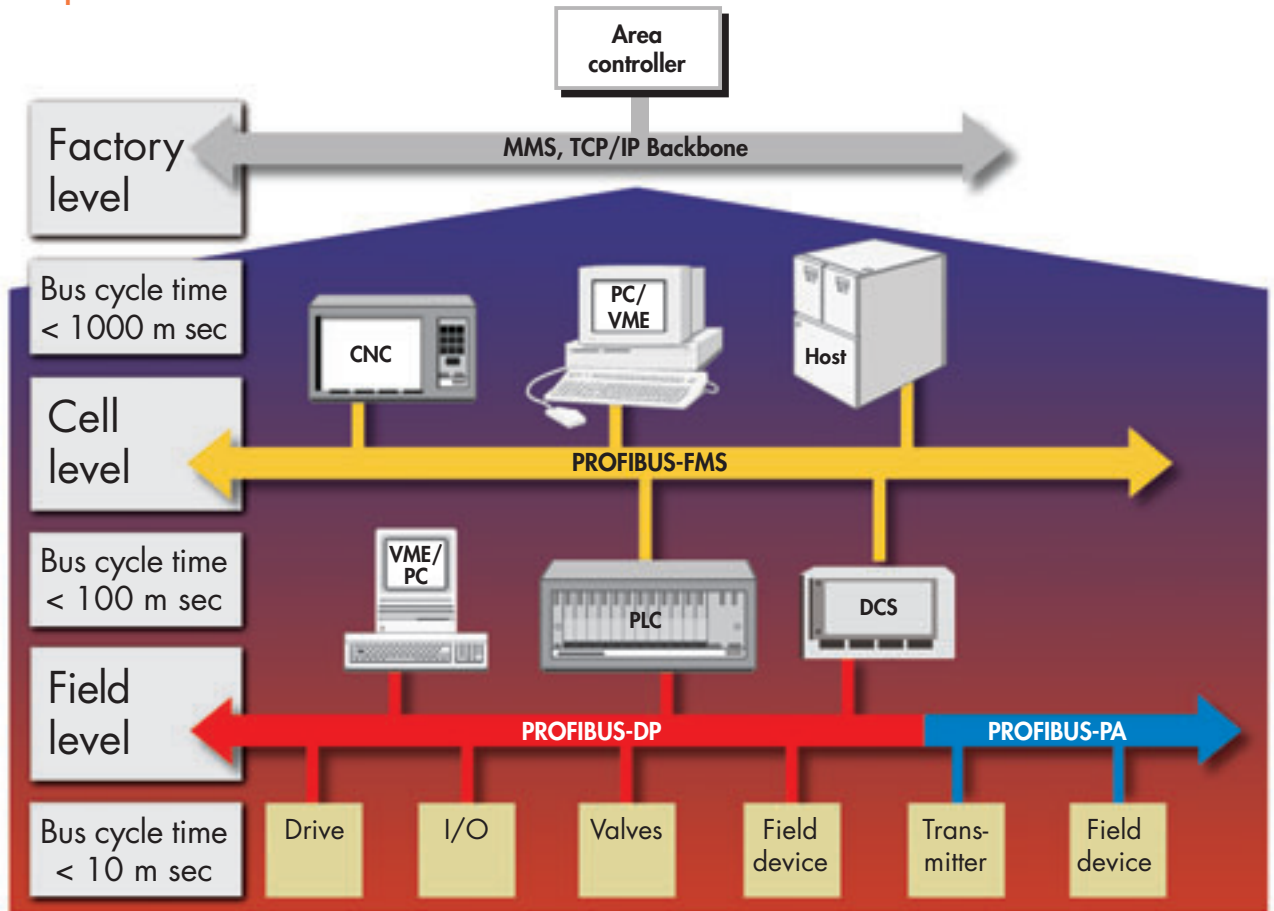

Application level of the Profibus

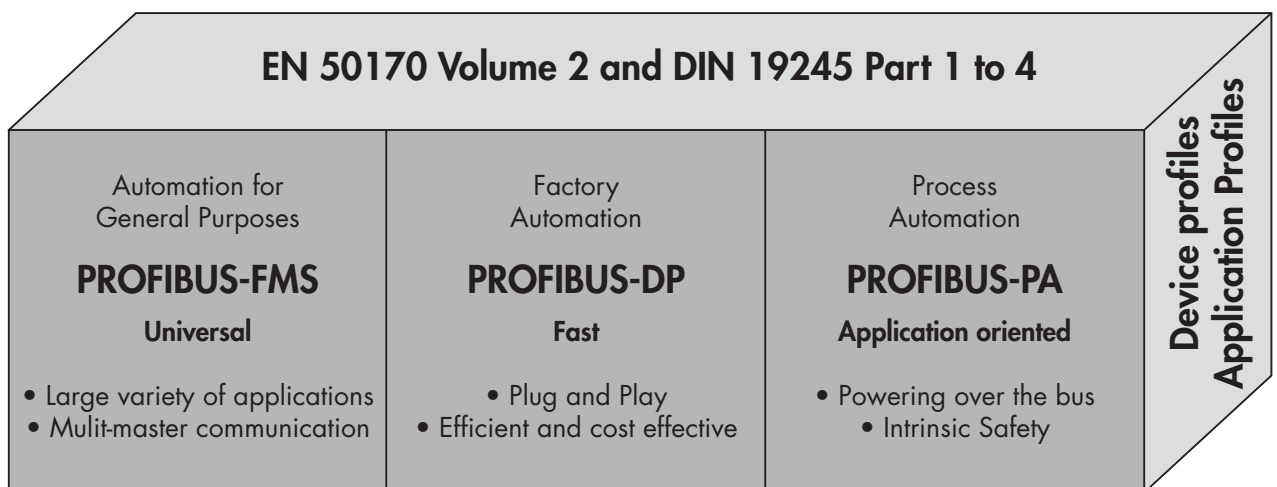

Profi-BUS Family

# AS Interface Bus Cable

## AS Interface Bus Leitung

### Applications

Actuator-Sensor-Interface (ASI) bus cable to interconnect all ASI-components. This fieldbus allows data and power transmission at the same time. Due to its construction both easy and quick connection as well as displacement is supported. Its special shape preserves users from wrong installation. Used for signal loops within production and machine tool equipment.

### Anwendung

Actuator-Sensor-Interface (ASI) Busleitung zur Verbindung aller ASI Komponenten. Dieser Feldbus erlaubt die zeitgleiche Übertragung sowohl von Daten als auch von Energie. Durch den Kabelaufbau, der schnelle und einfache Verbindungen ermöglicht. Der Profilaufbau verhindert zusätzlich eine fehlerhafte Installation. Anwendung im Bereich Signalkreisläufe innerhalb von Produktionsanlagen und Werkzeugmaschinen.

### Design

(rubber version) 2 x 1.5 qmm  
art. 48210165

1. **Conductor**  
stranded tinned copper class 6  
IEC 60228
2. **Insulation**  
rubber

### Aufbau

(Gummi Variante) 2 x 1.5 qmm  
Art. 482101

1. **Leiter**  
Verzinnnte Litze Leiterklasse 6  
nach IEC 60228
2. **Isolierung**  
Gummi

3. **Construction**  
two cores in parallel
4. **Outer Jacket**  
rubber in a special profile  
yellow

3. **Aufbau**  
zwei Adern parallel
4. **Außenmantel**  
Gummi in Spezialabmessung  
gelb



### Marking

week and year of production

### Bedruckung

Herstellwoche/-jahr

### Core Identification

brown and blue

### Aderfarben

Braun und blau

### Standards

According AS-Interface Standard

Jacket colour	yellow	32 volt
	black	48 volt
	red	230 volt

### Norm/Anforderung













Gemäß AS-Interface Standard

Mantelfarbe	gelb	32 volt
	schwarz	48 volt
	rot	230 volt

## AS Interface Bus Cable AS Interface Bus Leitung

Type	Art-no.	Conductor	Jacket	Copper content kg/km	weight kg/km	Application
2x1,5 3G3G	48210165	76x0,15 tinned	rubber yellow	ca. 29,0	ca. 85	self healing effect, very soft
2x1,5 3G3G	48210116	76x0,15 tinned	rubber black	ca. 29,0	ca. 85	self healing effect, very soft
2x1,5 HI11Y	48216015	76x0,15 tinned	PUR black	ca. 29,0	ca. 85	chemical resistance
2x1,5 HI11Y	48216065	76x0,15 tinned	PUR yellow	ca. 29,0	ca. 85	chemical resistance

Typ	Artikelnr.	Leiter	Mantel	Kupferzahl kg/km	Gewicht kg/km	Anwendung
2x1,5 3G3G	48210165	76x0,15 verzinkt	Gummi gelb	ca. 29,0	ca. 85	Selbstheilungseffekt, sehr weich
2x1,5 3G3G	48210116	76x0,15 verzinkt	Gummi schwarz	ca. 29,0	ca. 85	Selbstheilungseffekt, sehr weich
2x1,5 HI11Y	48216015	76x0,15 verzinkt	PUR schwarz	ca. 29,0	ca. 85	chemische Beständigkeit
2x1,5 HI11Y	48216065	76x0,15 verzinkt	PUR yellow	ca. 29,0	ca. 85	chemische Beständigkeit

Type Typ	Art-no. Artikelnr.	            										
2x1,5 3G3G	48210165	-25 °C to black +85 °C schwarz	•	•	•	•	•	•	•	•	•	•
2x1,5 3G3G	48210116	-25 °C to +85 °C	•	•	•	•	•	•	•	•	•	•
2x1,5 HI11Y	48216015	-25 °C to black +80 °C schwarz	•	•	•	•	•	•	•	•	•	•
2x1,5 HI11Y	48216065	-25 °C to +80 °C	•	•	•	•	•	•	•	•	•	•

# Interbus

## Applications

Interbus cables connect sensors and actors with all standard equipment in automation. Our product range fulfill the special requirement of

- Standard for fix installation or few bending
- For use in chain
- HFFR (Halogen free & flame retardant)
- Direct burial
- Food industry
- Marine and Submarine
- Railway Systems

## Anwendung

Interbus Leitungen verbinden Sensoren, Aktoren und Buskomponenten mit allen Standardausrüstungen im Automationsbereich. Unser Lieferprogramm erfüllt spezielle Anforderungen wie

- Feste Installation oder gelegentliche Bewegung
- Für den Einsatz in der Schleppkette
- HFFR (halogenfrei und flammwidrig)
- Direkte Erdverlegung
- Nahrungsmittelindustrie
- Marine und U-Boote
- Schienenfahrzeuge

## Design

(standard) 3 x 2 x AWG 24/7  
PVC art. 444 765 89

- 1. Conductor**  
bare stranded copper  
AWG 24/7
- 2. Insulation**  
PE

## Aufbau

(Standard) 3 x 2 x AWG 24/7  
PVC art. 444 765

- 1. Leiter**  
Kupferlitze blank  
AWG 24/7
- 2. Isolierung**  
PE

- 3. Twisting**  
two cores to pair,  
3 pairs together
- 4. Screen**  
bare copper braid
- 5. Outer sheath**  
PVC, violett

- 3. Verseilung**  
zwei Adern zum Paar, 3 Paare  
gesamtverseilt
- 4. Schirm**  
blankes Kupfergeflecht
- 5. Außenmantel**  
PVC, violett



## Marking

week and year production

## Bedruckung

Herstellwoche/-jahr

## Core Identification

white/brown  
grey/pink  
yellow/green

## Aderfarben

weiß/braun  
grau/pink  
gelb/grün

## Standards

According Interbus requirements













## Norm/Anforderung

Gemäß Interbus Anforderungen

# Interbus

Type	Art-no.	Conductor	Jacket	Copper content kg/km	weight kg/km	Application
3x2xAWG24/19 2YC11Y	444764	Bare copper stranded AWG 24/19	PUR violet 7,8 mm	34,7	76	Chain cable
3x2xAWG24/7 2YCY	444765	Bare copper stranded AWG 24/7	PVC violet 7,0 mm	32,4	70	Standard cable for fixed installation or some movement
3x2xAWG24/7 + 3x1,0 2YCY	444771	Bare copper stranded AWG 24/7 (bus) x 3x1,0 mm <sup>2</sup>	PVC violet 8,0 mm	56,7	109	Installation bus plus power supply for fix installation or some movement
3x2xAWG24/7 + 3x1,0 2YC11Y	444982	Bare copper stranded AWG 24/7 (bus) x 3x1,0 mm <sup>2</sup>	PUR violet 8,6 mm	66,2	108	Installation bus with power supply Chain cable

Typ	Art-No.	Leiter	Mantel	Kupferzahl kg/km	Gewicht kg/km	Anwendung
3x2xAWG24/19 2YC11Y	444764	Cu-Litze blank AWG 24/19	PUR violett 7,8 mm	34,7	76	Schleppkettenkabel
3x2xAWG24/7 2YCY	444765	Cu-Litze blank AWG 24/7	PVC violett 7,0 mm	32,4	70	Standardkabel für feste oder gering bewegliche Installation
3x2xAWG24/7 + 3x1,0 2YCY PUR	444771	Cu-Litze blank AWG 24/7 (Bus) x 3x1,0 mm <sup>2</sup>	PVC violett 8,0 mm	56,7	109	Installationsbus mit Stromversorgung für feste oder gering bewegliche Installation
3x2xAWG24/7 + 3x1,0 2YC11Y	444982	Cu-Litze blank AWG 24/7 (Bus) x 3x1,0 mm <sup>2</sup>	PUR violett 8,6 mm	66,2	108	Installationsbus mit Stromversorgung Schleppkettenkabel

Type Typ	Art-no. Art.-Nr.	           				
3x2xAWG24/19 2YC11Y	444764	-20° C to in +70 °C black	• •			• • • • •
3x2xAWG24/7 2YCY	444765	-20 °C in +70 °C black	• • •			• • • • •
3x2xAWG24/7 + 3x1.0 2YCY	444771	-20 °C in +70 °C black	• • •			• • • • •
3x2xAWG24/7 + 3x1.0 2YC11Y	444982	-20 °C in +70 °C black	• • •			• • • • •

# Profibus Cable

new design Quick Strip available

## Profibus Leitungen

neuer Aufbau Quick Strip verfügbar

### Applications

Bus cable family facilitating interconnections for L2 BUS components.

- Standard for fixed installation, buildings, machine equipment
- High flexible for machine tool and automation equipment
- HFFR (Halogen free & flame retardant)
- Quick Strip property for special stripping tool
- Direct burial
- Harsh and aggressive environments
- Marine and Submarine
- Railway Systems

### Anwendung

Für die Verbindung von Profibuskomponenten Standard für feste Verlegung in Gebäuden, Maschinen und Equipment.

- Hochflexibel für Werkzeugmaschinen und Automationsanlagen
- HFFR (halogenfrei und flammwidrig)
- „Quick Strip“ Eigenschaft für spezielles Abmantelungs-Werkzeug (kompatibel Fast Connect)
- Direkte Erdverlegung
- Raue und aggressive Umgebungsbedingungen
- Schiff und Marine
- Schienenfahrzeuge

### Design

(for fixed installation 1x2xAWG22/1)

Art. 44475989

- 1. Conductor**  
bare solid wire AWG 22/1
- 2. Insulation**  
foamed polyethylene

### 3. Twisting

two cores to a pair

### 4. Screen

aluminium tape + tinned copper braid

### 5. Outer sheath/Jacket

PVC colour violet

### Aufbau

(feste Verlegung 1x2xAWG22/1)

Art. 44475989

- 1. Leiter**  
AWG 22/1 Massivdraht blank  
(0,64 mm Ø)
- 2. Isolierung**  
Schaum-PE  
2,55 mm Ø

### 3. Verseilung

zwei Adern werden mit Füllern zum Paar verseilt

### 4. Schirm

Aluminiumfolie + verzinnertes Kupfergeflecht

### 5. Außenmantel/Mantel

PVC Farbe violett 8,0 +/- 0,4 mm



### Marking

week and year of production

### Bedruckung

Herstellwoche/-jahr

### Core Identification

red and green colour

### Aderfarben

Rot und grün

### Standards

According profibus requirements

### Norm/Anforderung

Gemäß Profibus Anforderungen



## Profibus Cables Profibus Leitung











Type	Art-no.	Conductor	Jacket	Copper content kg/km	weight kg/km	Application
1x2x0,30 mm <sup>2</sup> 02YSH(ST)D11Y	444 821	bare copper stranded 19x0,14	PUR violet 8,0 mm ± 0,4	ca. 23,3	ca. 86	Torsion cable (robotic)
1x2xAWG22/1 02YS(ST)CY	444 773	solid bare copper AWG 22/1	HFFR violet 8,0 mm ± 0,4	ca. 22,4	ca. 73	halogen free and flame retardent for fixed installation cable
1x2xAWG22/1 02YS(ST)CY QUICK STRIP	444 816	solid bare copper AWG 22/1	HFFR violet 8,0 mm ± 0,4	ca. 18,5	ca. 88	halogen free and flame retardent for fixed installation cable QUICK STRIP
1x2xAWG22/1 02YSH(ST)C11Y QUICK STRIP	444 840	solid bare copper AWG 22/1	PUR violet 8,0 mm ± 0,4	ca. 18,5	ca. 84	cable for fixed installation QUICK STRIP
1x2xAWG22/1 02YSH(ST)C11Y	444 841	solid bare copper AWG 22/1	PUR violet 8,0 mm ± 0,4	ca. 18,6	ca. 66	cable for fixed installation
1x2xAWG22/1 02YS(ST)CY	444 759	solid bare copper AWG 22/1	PVC violet 8,0 mm ± 0,4	ca. 18,8	ca. 67	Standard cable for fixed installation
1x2xAWG22/1 02YS(ST)C11Y	444 756	solid bare copper AWG 22/1	PUR violet 8,0 mm ± 0,4	ca. 19,0	ca. 63	Fix installation oil and cool liquid resistance
1x2xAWG22/1 02YS(ST)C2Y	444 779	solid bare copper AWG 22/1	PE black 8,0 mm ± 0,4	ca. 18,8	ca. 58	Fix installation in food industry or outdoor use (not direct burial)
1x2xAWG22/1 02YS2Y(ST)CY QUICK STRIP (opt. UL 2560)	444 775 (444847)	solid bare copper AWG 22/1	PVC violet 8,0 mm ± 0,4	ca. 18,7	ca. 86	Fix installation for special stripping tool QUICK STRIP
1x2xAWG22/1 02YS(ST)CY2Y	444 760	solid bare copper AWG 22/1	PVC violet + PE black 10,0 mm ± 0,4	ca. 18,6	ca. 99	Direct burial and outdoor
1x2xAWG24/19 Li 02Y(ST)C11Y	444 763	bare copper stranded AWG 24/19	PUR violet 8,0 mm ± 0,4	ca. 19,6	ca. 64	for drag chain
1x2xAWG24/19 UL 20236	444762	bare copper stranded AWG 24/19	PUR violet 8,0 mm ± 0,4	ca. 19,6	ca. 69	for drag chain, UL recognised
1x2xAWG24/19 + 3 x 0,75 9YI(ST)C11Y (opt. UL 20236)	444739 (444809)	bare copper stranded AWG 24 (bus) Power 0,75 mm <sup>2</sup>	PUR violet 9,6 mm ± 0,4 (UL 10,3 mm)	ca. 42,4	ca. 108	for drag chain Profibus plus power supply
1x2xAWG24/19 02YS2Y(ST)C11Y QUICK STRIP (opt. UL 20236)	444788 (444848)	bare copper stranded AWG 24/19	PUR violet 8,0 mm ± 0,4	ca. 19,7	ca. 82	for drag chain QUICK STRIP
1x2xAWG24/7 7-wire 02YS(ST)CH	444691	bare copper stranded AWG 24/7	HFFR violet 8,0 mm ± 0,4	ca. 17,0	ca. 67	7-wire halogen free

## Profibus Cables Profibus Leitung

Typ	Art-Nr.	Leiter	Mantel	Kupferzahl kg/km	Gewicht kg/km	Anwendung
1x2x0,30 mm <sup>2</sup> 02YSH(ST)D11Y	444 821	Cu-Litze blank 19x0,14	PUR violett 8,0 mm ± 0,4	ca. 23,3	ca. 86	Torsionskabel (Robotik)
1x2xAWG22/1 02YS(ST)CY	444 773	Cu-Draht blank AWG 22/1	HFFR violett 8,0 mm ± 0,4	ca. 22,4	ca. 73	Halogenfreies und flammwidriges Kabel für feste Installation
1x2xAWG22/1 02YS(ST)CY QUICK STRIP	444 816	Cu-Draht blank AWG 22/1	HFFR violett 8,0 mm ± 0,4	ca. 18,5	ca. 88	Halogenfreies und flammwidriges Kabel für feste Installation QUICK STRIP
1x2xAWG22/1 02YSH(ST)C11Y QUICK STRIP (opt. UL 2560)	444 840 (444847)	Cu-Draht blank AWG 22/1	PUR violett 8,0 mm ± 0,4	ca. 18,5	ca. 84	Robustes Kabel für feste Installation QUICK STRIP
1x2xAWG22/1 02YSH(ST)C11Y	444 841	Cu-Draht blank AWG 22/1	PUR violett 8,0 mm ± 0,4	ca. 18,6	ca. 66	Robustes Kabel für feste Installation
1x2xAWG22/1 02YS(ST)CY	444 759	Cu-Draht blank AWG 22/1	PVC violett 8,0 mm ± 0,4	ca. 18,8	ca. 67	Standardkabel für feste Installation
1x2xAWG22/1 02YS(ST)C11Y	444 756	Cu-Draht blank AWG 22/1	PUR violett 8,0 mm ± 0,4	ca. 19,0	ca. 63	Kabel für feste Installation, beständig gegen Öl und Kühlmittel
1x2xAWG22/1 02YS(ST)C2Y	444 757	Cu-Draht blank AWG 22/1	PE schwarz 8,0 mm ± 0,4	ca. 18,8	ca. 58	Kabel für feste Installation in der Lebensmittelindustrie oder im Freien (keine direkte Erdverlegung)
1x2xAWG22/1 02YS2Y(ST)CY QUICK STRIP	444 775	Cu-Draht blank, massiv AWG 22/1	PVC violett 8,0 mm ± 0,4	ca. 18,7	ca. 86	Kabel für feste Installation für Spezialwerkzeuge QUICK STRIP
1x2xAWG22/1 02YS(ST)CY2Y	444 760	Cu-Draht blank, massiv AWG 22/1	PVC violett + PE schwarz 10,0 mm ± 0,4	ca. 18,6	ca. 99	Kabel für direkte Erdverlegung und Einsatz im Freien
1x2xAWG24/19 Li 02Y(ST)C11Y	444 763	Cu-Litze blank AWG 24/19	PUR violett 8,0 mm ± 0,4	ca. 19,6	ca. 64	Schleppkettenkabel
1x2xAWG24/19 UL 20236	444762	Cu-Litze blank AWG 24/19	PUR violett 8,0 mm ± 0,4	ca. 19,6	ca. 69	Schleppkettenkabel mit UL-Zulassung
1x2xAWG24/19 + 3 x 0,75 9YI(ST)C11Y (opt. UL 20236)	444739 (444809)	Cu-Litze blank AWG 24 (Bus) Power 0,75 mm <sup>2</sup>	PUR violett 9,6 mm ± 0,4 (UL 10,3 mm)	ca. 42,4	ca. 108	Schleppkettenkabel Profibus mit Stromversorgung
1x2xAWG24/19 02YS2Y(ST)C11Y QUICK STRIP (opt. UL 20236)	444788 (444848)	Cu-Litze blank AWG 24/19	PUR violett 8,0 mm ± 0,4	ca. 19,7	ca. 82	Schleppkettenkabel QUICK STRIP
1x2xAWG24/7 7-wire 02YS(ST)CH	444691	bare copper stranded AWG 24/7	HFFR violett 8,0 mm ± 0,4	ca. 17,0	ca. 67	7-wire halogen free

# Profibus Cables

## Profibus Leitung

Type Typ	Art-no. Art-Nr.													
1x2xAWG22/1 02YS(ST)CY	444759				•	•	•						•	•
1x2xAWG22/1 02YS(ST)C11Y	444756									•	•	•	•	•
1x2xAWG22/1 02YS(ST)C2Y	444757				•	•	•				•	•	•	•
1x2xAWG22/1 02YS2Y(ST)CY QUICK STRIP	444775				•	•	•						•	•
1x2xAWG22/1 02YS(ST)CY2Y	444760				•	•	•						•	•
1x2xAWG24/19 Li 02Y(ST)C11Y	444763				•	•			•	•	•	•	•	•
1x2xAWG24/19 UL 20236	444762				•	•	•		•	•	•	•	•	•
1x2xAWG24/19 + 3 x 0,75 9YI(ST)C11Y (opt. UL 20236)	444739				•	•	•		•	•	•	•	•	•
1x2xAWG24/19 02YS2Y(ST)C11Y QUICK STRIP (opt. UL 20236)	444788 (444848)				•	•	•		•	•	•	•	•	•

# Hybrid Bus Cable

## Hybrid Bus Leitung

### Applications

Used within machine tool or production equipment. Polymer optic fibers provide maximum EMI resistance. Copper cores transport power to controlled hydraulic and other actuators and sensors. Suitable for harsh environments due to materials and design used.

### Anwendung

Wird in Werkzeugmaschinen oder Produktionsanlagen genutzt. Polymeroptische Fasern sind EMV sicher (elektromagnetische Verträglichkeit). Kupferleiter sind für die Spannungsversorgung zuständig. Geeignet für raue Umgebungen aufgrund des verwendeten Materials und Aufbaus.

### Design

(POF + 4 x 1,5 mm<sup>2</sup> PUR)  
44479489

#### 1. Conductor

Polymer Optical Fiber (bus)  
+ bare copper stranded conductor  
with 1,5 mm<sup>2</sup> (power)

#### 2. Insulation

Polyolefin POF  
PP (power)

#### 3. Twisting

two POFs twisted with fillers and with four power cores and wrapped with a tape

#### 4. Outer Jacket

PUR, violett, 9,0 mm

### Aufbau

(POF + 4 x 1,5 mm<sup>2</sup> PUR)  
44479489

#### 1. Leiter

Polymeroptische Faser (Bus)  
+ blanke Kupferlitze  
mit 1,5 mm<sup>2</sup> (Energieleitung)

#### 2. Isolierung

Polyolefin POF  
PP (Energieleitung)

#### 3. Verseilung

zwei POFs werden mit einem Füllelement und vier Energieadern verseilt und mit Folie bandiert

#### 4. Außenmantel

PUR, violett, 9,0 mm



### Marking

week and year of production

### Core Identification

power cores black with numbers  
bus cores red and green  
POF cores with numbers

### Standards

acc. DESINA and Profibus requirements

### Bedruckung

Herstellwoche/-jahr

### Adernfarben

Energieleiter schwarz mit Nummern  
BUS Leiter rot und grün  
POF Leiter mit Nummern/Ziffern













### Norm/Anforderungen

Gemäß Profibus und DESINA Anforderungen

## Hybrid Bus Cable Hybrid Bus Leitung

Type	Art-no.	Conductor	Jacket	Copper content kg/km	weight kg/km	Application
Twin-Tech-Buscable 1x2xAWG24 + 4x1,5	44474289	bare copper stranded 1,5 mm <sup>2</sup>	PUR violet Ø 11,2 mm ± 0,3	ca. 78	ca. 161	combined Energy/Bus cable for drag chain
Twin-Tech-Hybridcable HSL18Y 4x1,5 + 2 POF	44479489	bare copper stranded 1,5 mm <sup>2</sup>	PUR violet Ø 8,8 mm ± 0,2	ca. 55,8	ca. 102	as combined Energy/Control cable in for drag chain

Typ	Art-Nr.	Leiter	Mantel	Kupferzahl kg/km	Gewicht kg/km	Anwendung
Twin-Tech-Buscable 1x2xAWG24 + 4x1,5	44474289	Litzenleiter blank 1,5 mm <sup>2</sup>	PUR violett Ø 11,2 mm ± 0,3	ca. 78	ca. 161	Kombiniertes Energie-/Bus- Schleppkettenkabel
Twin-Tech-Hybridcable HSL18Y 4x1,5 + 2 POF	44479489	Litzenleiter blank 1,5 mm <sup>2</sup>	PUR violett Ø 8,8 mm ± 0,2	ca. 55,8	ca. 102	Als kombiniertes Energie-/ Steuerkabel für Einsatz in Schleppketten

Type Typ	Art-no. Art-Nr.	            		
1P24 + 4x1,5	44474289	-40 °C to black +80 °C sheath	• •	• • • • •
4x1,5 + 2 POF	44479489	-20 °C black +70 °C sheath	• •	• • • • •

# Profibus PA

## Applications

100 Ohm data transfer cable for fixed laying.  
Max. 31,25 kBit/s

## Anwendung

Bauartnorm für festverlegte 100 Ohm Datenübertragungsleitung für eine maximale Übertragungsgeschwindigkeit von 31.25 kBit/s

## Design

1. **Conductor**  
bare copper wire AWG 18/1
2. **Insulation**  
PE
3. **Twisting**  
two cores were stranded to a pair and wrapped with a plastic-foil

4. **Screen**  
aluminium foil + tinned copper braid
5. **Outer sheath/Jacket**  
PVC (blue or black)

## Aufbau

1. **Leiter**  
Kupfer blank AWG 18/1
2. **Isolierung**  
PE
3. **Verseilung**  
zwei Adern werden zum Paar verseilt und mit Kunststofffolie umwickelt

4. **Schirm**  
Aluminiumfolie + Kupfergeflecht verzinkt
5. **Außenmantel/Mantel**  
PVC (blau oder schwarz)



## Marking

week and year of production

## Bedruckung

Herstellwoche/-jahr

## Core Identification

red and green colour

## Aderfarben

Rot und grün

## Standards

According profibus requirements

## Norm/Anforderung

Gemäß Profibus Anforderungen

## Profibus PA

Type	Art-no.	Conductor	Jacket	Copper content kg/km	weight kg/km	Application
1x2x1,0/2,55 2Y(ST)CY	444 734	solid bare copper AWG 18/1	PVC blue Ø 7,7 mm ± 0,2	ca. 42,7	ca. 76	fix installation
1x2x1,0/2,55 2Y(ST)CY	444 734	solid bare copper AWG 18/1	PVC black Ø 7,7 mm ± 0,2	ca. 42,7	ca. 76	fix installation

Typ	Art-Nr.	Leiter	Mantel	Kupferzahl kg/km	Gewicht kg/km	Anwendung
1x2x1,0/2,55 2Y(ST)CY	444 734	Cu-Draht blank, massiv AWG 18/1	PVC blau Ø 7,7 mm ± 0,2	ca. 42,7	ca. 76	Kabel für feste Installation
1x2x1,0/2,55 2Y(ST)CY	444 734	Cu-Draht blank, massiv AWG 18/1	PVC schwarz Ø 7,7 mm ± 0,2	ca. 42,7	ca. 76	Kabel für feste Installation

Other designs with stranded conductor conductors, other cross sections or Quick Strip Design as special design possible. Please ask us.

Spezielle Aufbauten mit Litzenleiter, anderen Querschnitten oder Quick Strip Design auf Kundenwunsch. Bitte sprechen Sie uns an.

# Industrial Ethernet/Profinet Cable Industrial Ethernet/Profinet Bus Leitung

## Applications

Communication between automation equipment and computer systems within factories and production machinery. Suitable for industrial twisted pair networks facilitating ISDN connection and WAN (Wide Area Network)

## Anwendung

Kommunikation zwischen Maschinen und Computersystemen innerhalb von Fabriken und Produktionsanlagen über Ethernet Anbindung.

## Design

(fixed installation)  
44482079

1. **Conductor**  
bare solid wire AWG 22/1
2. **Insulation**  
PE
3. **Twisting**  
two cores to a pair and two pairs together

4. **Inner Jacket**  
special halogen free material, easy to ship
5. **Screen**  
aluminium tape + tinned copper braid
6. **Outer Jacket**  
PVC, green

## Aufbau

(fest Verlegung Standard)  
44482079

1. **Leiter**  
blanker massiver Kupferdraht AWG 22/1
2. **Isolierung**  
PE
3. **Verseilung**  
zwei Adern zum Paar + zwei Adern zusammen

4. **Innenmantel**  
spezielles halogenfreies leicht abisolierbares Material
5. **Schirm**  
Aluminiumfolie und verzinnntes Kupfergeflecht
6. **Außenmantel**  
PVC, grün



## Marking

week and year of production

## Bedruckung

Herstellwoche/-jahr

## Core Identification

orange + blue  
white + yellow

## Aderfarben

Orange und blau  
Weiß und gelb

## Standards

According Profinet

## Norm/Anforderung















Gemäß Profinet



## Industrial Ethernet/Profinet Cable Industrial Ethernet/Profinet Leitung

Type	Art-no.	Conductor	Jacket	Copper content kg/km	weight kg/km	Application
2x2xAWG22/1 2YH(ST)CY	444820	AWG 22/1 (0,32 qmm)	PVC violet 6,5 mm	29	66	installation cable
2x2xAWG22/7 2YH(ST)C11Y	444917	AWG 22/7 (0,35 qmm)	PUR violet 6,9 mm	29	70	trailing cable
2x2xAWG22/7 2YH(ST)CH	444xxxxx	AWG 22/7 (0,35 qmm)	HFFR violet 6,5 mm	31,0	66	halogen free cable

Typ	Art-Nr.	Leiter	Mantel	Kupferzahl kg/km	Gewicht kg/km	Anwendung
2x2xAWG22/1 2YH(ST)CY	444820	AWG 22/1 (0,32 qmm)	PVC violett 6,5 mm	29	66	Installationskabel
2x2xAWG22/7 2YH(ST)C11Y	444917	AWG 22/7 (0,385 qmm)	PUR violett 6,9 mm	29	70	Schleppkabel
2x2xAWG22/7 2YH(ST)CH	444xxxxx	AWG 22/7 (0,35 qmm)	HFFR violett 6,5 mm	31,0	66	halogenfrei

Type Typ	Art-no. Art-Nr.	             											
2x2xAWG22/1 2YH(ST)CY	444705	-40 °C to black +70 °C sheath	•	•	•							•	•
2x2xAWG22/19 2YH(ST)C11Y	444917	-40 °C to black +70 °C sheath	•	•				•	•	•	•	•	•
2x2xAWG22/7 2YH(ST)CH	444xxx	-20 °C to black +70 °C sheath	•		•	•	•	•			•	•	•

# Can-Bus Cable

## Can-Bus Leitung

### Applications

Bus cable to connect Controller Area Network components. Transmission characteristics:

1 Mbit/s up to 40 m

50 Kbit/s up to 1 km

Flexible cable to be used for machinery equipment and industrial environments. Suitable for harsh environments.

### Anwendung

Busleitung zur Verbindung von Netzwerk Umgebungs-komponenten.

Übertragungs-kenn-daten:

1 Mbit/s bis zu 40 m

50 Kbit/s bis zu 1 km

Flexible Leitung zum Einsatz in Produktions-anlagen und industriellen Umgebungen.

Geeignet für raue Umgebungsbedingungen.

### Design

(CAN BUS flex) 1x2x0,25 PUR

Art. 44469789

1. **Conductor**  
bare stranded copper  
0,25 mm<sup>2</sup>
2. **Insulation**  
PE

3. **Twisting**  
two cores to a pair
4. **Screen**  
tinned copper braid
5. **Outer sheath/Jacket**  
PUR, violet, Ø 6,0 mm

### Aufbau

(flexibler CAN BUS) 1x2x0,25 PUR

Art. 44469789

1. **Leiter**  
blanker Litzenleiter  
0,25 mm<sup>2</sup>
2. **Isolierung**  
PE

3. **Verseilung**  
zwei Adern werden zum Paar verseilt
4. **Schirm**  
verzinnertes Kupfergeflecht
5. **Außenmantel**  
PUR, violett, Ø 6,0 mm



### Marking

week and year of production

### Bedruckung

Herstellwoche/-jahr

### Core Identification

white/brown (two cores)

green/yellow and white/brown (four cores)

### Aderfarben

Weiß/braun (zweiadrig)

Grün/gelb und weiß/braun (vieradrig)

### Standards

CAN standard and customers requirements













### Norm/Anforderung

gem. CAN Standard und Kundenwunsch

## Can-Bus Cable Can-Bus Leitung

Type	Art-no.	Conductor	Jacket	Copper content kg/km	weight kg/km	Application
1P0,25/1,80 2YC11Y (CAN-BUS flex)	444 697	bare copper stranded 0,25 mm <sup>2</sup>	PUR violet Ø 6,0 mm ± 0,2	ca. 17,8	ca. 42	Chain cable
2x2x0,25/1,60 2YC11Y (CAN-BUS flex)	444 698	bare copper stranded 0,25 mm <sup>2</sup>	PUR violet Ø 6,3 mm ± 0,2	ca. 25,7	ca. 53	Chain cable
1x2xAWG24/7 2YCY (CAN-BUS)	444 695	bare copper stranded 0,23 mm <sup>2</sup>	PVC violet Ø 5,4 mm ± 0,2	ca. 13,5	ca. 38	Installation some moving
2x2xAWG24/7 2YCY (CAN-BUS)	444 696	bare copper stranded 0,23 mm <sup>2</sup>	PVC violet Ø 7,1 mm ± 0,2	ca. 21,3	ca. 47	Installation some moving

Typ	Art-Nr.	Leiter	Mantel	Kupfergehalt kg/km	Gewicht kg/km	Anwendung
1P0,25/1,80 2YC11Y (CAN-BUS flex)	444 697	Cu-Litze blank 0,25 mm <sup>2</sup>	PUR violett Ø 6,0 mm ± 0,2	ca. 17,8	ca. 42	Schleppkettenkabel
2x2x0,25/1,60 2YC11Y (CAN-BUS flex)	444 698	Cu-Litze blank 0,25 mm <sup>2</sup>	PUR violett Ø 6,3 mm ± 0,2	ca. 25,7	ca. 53	Schleppkettenkabel
1x2xAWG24/7 2YCY (CAN-BUS)	444 695	Cu-Litze blank 0,23 mm <sup>2</sup>	PVC violett Ø 5,4 mm ± 0,2	ca. 13,5	ca. 38	Gering bewegliche Installation
2x2xAWG24/7 2YCY (CAN-BUS)	444 696	Cu-Litze blank 0,23 mm <sup>2</sup>	PVC violett Ø 7,1 mm ± 0,2	ca. 21,3	ca. 47	Gering bewegliche Installation

Type Typ	Art-no. Art-Nr.	            										
1P0,25/1,80 2YC11Y (CAN-BUS flex)	444 697	-20 °C to black +70 °C sheath	•	•		•	•	•	•	•	•	•
2x2x0,25/1,60 2YC11Y (CAN-BUS flex)	444 698	-20 °C to black +70 °C sheath	•	•		•	•	•	•	•	•	•
1x2xAWG24/7 2YCY (CAN-BUS)	444 695	-20 °C to black +70 °C sheath	•	•	•		•			•	•	•
2x2xAWG24/7 2YCY (CAN-BUS)	444 696	-20 °C to black +70 °C sheath	•	•	•		•			•	•	•

### Applications

DeviceNet is one of the world's leading device-level networks for industrial automation. This bus system offers data transmission and power supply in one cable. **The special twisting design allows higher bending cycles than competitors traditional parallel twisting.**

### Anwendung

*DeviceNet ist ein internationaler Standard in der Geräteverdrahtung in der Automatisierungstechnik. Dieses Bussystem bietet die Datenübertragung und Spannungsversorgung in einem Kabel. Die Spezialverseilung erlaubt höhere Biegezyklen als vergleichbar aufgebaute Wettbewerbsleitungen mit parallel laufenden Adern.*

### Design

1x2xAWG24/19 + 1x2xAWG22/19  
PUR DeviceNet Drop Cable

#### 1. Conductor

tinned stranded copper  
19 wires (AWG22)  
19 wires (AWG24)

#### 2. Insulation

PP (AWG22 power cores)  
foam PE (AWG24 data cores)

#### 3. Twisting/pair screen

two data cores to a pair and screened with aluminium foil overall  
two power cores and drain wire

#### 4. Screen

tinned copper braid

#### 5. Outer sheath/Jacket

PUR, violet, Ø 6,4 mm

### Aufbau

1x2xAWG24/19 + 1x2xAWG22/19  
PUR

#### 1. Leiter

verzinnnte Litzenleiter  
19-drahtig (AWG22)  
19-drahtig (AWG24)

#### 2. Isolierung

PP (AWG22 Spannungsversorgung)  
Schaum-PE (AWG24 Datenadern)

#### 3. Verseilung

zwei Adern werden zum Paar verseilt und mit Alufolie geschirmt. Darüber liegen die beiden Spannungsadern in den Außenwickeln sowie Beilauflitzen

#### 4. Schirm

verzinnntes Geflecht

#### 5. Außenmantel

PUR, violett, Ø 6,4 mm

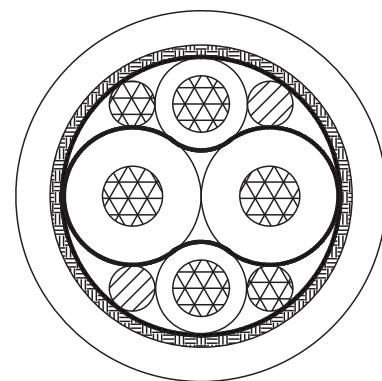

### Marking

designation and approbation and week/year of production

### Bedruckung

Bezeichnung und Zulassung und Herstellwoche/-jahr

### Core Identification

white/blue (data)  
red/black (power)

### Aderfarben

Weiß/blau (Datenpaar)  
Rot/schwarz (Spannungsversorgung)

### Standards

acc. DeviceNet

### Norm/Anforderung

gemäß DeviceNet

## DeviceNet

Type	Art-no.	Conductor	Jacket	Copper content kg/km	weight kg/km	Application
1x2xAWG24/19 + 1x2xAWG22/19	49500307	bare copper AWG 24/19 tinned copper AWG 22/19	PUR violet 6,4 mm	ca. 32	ca. 61	thin cable
1x2xAWG18/19 + 1x2xAWG15/19	49500306	bare copper AWG 18/19 tinned copper AWG 22/19	PUR violet 10,8 mm	ca. 100	ca. 339	thick cable

Typ	Art-Nr.	Leiter	Mantel	Kupferzahl kg/km	Gewicht kg/km	Anwendung
1x2xAWG24/19 + 1x2xAWG22/19	49500307	Cu blank AWG 24/19 Cu verzinkt AWG 22/19	PUR violett 6,4 mm	ca. 32	ca. 61	kleine Leitung
1x2xAWG18/19 + 1x2xAWG15/19	49500306	Cu blank AWG 18/19 Cu verzinkt AWG 22/19	PUR violett 10,8 mm	ca. 100	ca. 339	Stammleitung

Other versions possible (PVC, HFFR, 7-strands). Please do not hesitate to contact us.

Andere Aufbauten möglich (PVC, halogenfrei, 7-drähtig). Bitte fragen Sie uns.

# Trailing Sensor Cable

New developed insulation material TPM with enhanced mechanical and electrical properties available.  
Complete halogen free and flame retardant design with UL & CSA approval on request.

## Schleppketten Sensor Leitung

Neuentwickeltes Isolationsmaterials TPM mit verbesserten mechanischen und elektrischen Eigenschaften verfügbar. Komplett halogenfreier und flammwidriger Aufbau mit UL- und CSA-Zulassung.

### Applications

Used to connect all types of sensors. Adapter cables are used for machinetool and production equipment. Used in harsh environment, under high mechanical stress and contact to oil and cooling agents.

### Anwendung

Zur Verbindung aller Arten von Sensoren. Die Adapterkabel kommen im Bereich Werkzeugmaschinen und Produktionsanlagen zum Einsatz. Zur Verwendung in kritischen Umgebungsbedingungen, bei mechanischer Belastung sowie Kontakt zu Ölen und Kühl- und Schmiermitteln.

### Design

(flexible version, PUR sheath)  
44475069

1. **Conductor**  
bare copper, stranded, 0,34 mm<sup>2</sup>
2. **Insulation**  
TPM

3. **Twisting**  
four cores twisted together
4. **Outer sheath**  
PUR, yellow, Ø 4,7 mm

### Aufbau

(flexible Version PUR-Mantel)  
44475069

1. **Leiter**  
blanke Kupferlitze 0,34 mm<sup>2</sup>
2. **Isolierung**  
TPM

3. **Verseilung**  
vier Adern werden verseilt
4. **Außenmantel**  
PUR, gelb, Ø 4,7 mm



### Marking

designation and approbation and week/year of production

### Bedruckung

Bezeichnung und Zulassung und Herstellwoche/-jahr

### Core Identification

white, blue, black, brown

### Aderfarben

Weiß, blau, schwarz, braun

### Standards

According DESINA requirements  
UL 21198 or 20549













### Norm/Anforderung

gem. Anforderungen nach DESINA  
UL 21198 oder 20549

## Trailing Sensor Cable Schleppketten Sensor Leitung

Type	Art-no.	Conductor	Jacket	Copper content kg/km	weight kg/km	Application
4x0,34 9YC11Y	444750	43 x 0,10 mm bare copper	PUR yellow 4,7 mm	13,5	30	Chain cable
4x0,34 LI9YY	444xxx	43 x 0,10 mm bare copper	PVC yellow 4,7 mm	13,5	30	Installation

Typ	Art-Nr.	Leiter	Mantel	Kupferzahl kg/km	Gewicht kg/km	Anwendung
4x0,34 9YC11Y	444750	43 x 0,10 mm Cu, blank	PUR yellow 4,7 mm	13,5	30	Schleppkettenkabel
4x0,34 LI9YY	444xxx	43 x 0,10 mm Cu, blank	PVC yellow 4,7 mm	13,5	30	Installationskabel

Type Typ	Art-no. Art-Nr.	            										
4x0,34 LIY11Y (CAN-BUS flex)	444750	-40 °C to +80 °C	•	•		•	•	•	•	•	•	•
4x0,34 LIYY	444xxx	-20 °C to +70 °C	•	•	•		•				•	•

# Technical Data BUS Cables

Type	Art.No.	impedance at frequency	attenuation at dB/km	capacity pf/km	conductor resistance Ohm per km	temperatur range		minimum bending radius		
						fixed laying	moving	fixed laying	moving*/installation	
<b>Profibus</b>	444759	150 Ohm	42 dB at 16 MHz	30	55	-20 °C - +70 °C	-5 °C - +70 °C	10xD	18xD	
	444779	150 Ohm	42 dB at 16 MHz	30	55	-20 °C - +70 °C	-5 °C - +70 °C	10xD	18xD	
	444760	150 Ohm	42 dB at 16 MHz	30	55	-20 °C - +70 °C	-5 °C - +70 °C	10xD	18xD	
	444762	150 Ohm	55 dB at 16 MHz	30	87	-40 °C - +70 °C	-20 °C - +60 °C	7,5xD	10xD	
	444763	150 Ohm	55 dB at 16 MHz	30	87	-40 °C - +70 °C	-20 °C - +60 °C	7,5xD	10xD	
	444739	150 Ohm	55 dB at 16 MHz	30	70	-40 °C - +70 °C	-20 °C - +60 °C	7,5xD	10xD	
	444809	150 Ohm	55 dB at 16 MHz	30	70	-40 °C - +70 °C	-20 °C - +60 °C	7,5xD	10xD	
	444775	150 Ohm	42 dB at 16 MHz	30	55	-20 °C - +70 °C	-5 °C - +70 °C	10xD	18xD	
	444847	150 Ohm	42 dB at 16 MHz	30	55	-20 °C - +70 °C	-5 °C - +70 °C	10xD	18xD	
	444821	150 Ohm	49 dB at 16 MHz	30	70	-40 °C - +70 °C	-20 °C - +60 °C	7,5xD	10xD	
	444773	150 Ohm	42 dB at 16 MHz	30	55	-20 °C - +70 °C	-5 °C - +60 °C	10xD	18xD	
	444816	150 Ohm	42 dB at 16 MHz	30	55	-20 °C - +70 °C	-5 °C - +60 °C	10xD	18xD	
	444840	150 Ohm	42 dB at 16 MHz	30	55	-40 °C - +70 °C	-20 °C - +70 °C	10xD	18xD	
	444841	150 Ohm	42 dB at 16 MHz	30	55	-40 °C - +70 °C	-20 °C - +70 °C	10xD	18xD	
	444788	150 Ohm	55 dB at 16 MHz	30	84	-40 °C - +70 °C	-20 °C - +60 °C	7,5xD	10xD	
	444848	150 Ohm	55 dB at 16 MHz	30	84	-40 °C - +70 °C	-20 °C - +60 °C	7,5xD	10xD	
	<b>Profibus PA</b>	444734	100 Ohm	3 dB at 39 kHz	55	22	-20 °C - +70 °C	-5 °C - +60 °C	9xD	18xD
	<b>Interbus</b>	444764	100 Ohm	2,7 dB at 1MHz	60	96	-40 °C - +70 °C	-20 °C - +60 °C	7,5xD	10xD
444765		100 Ohm	2,7 dB at 1MHz	60	96	-20 °C - +70 °C	-5 °C - +70 °C	7,5xD	15xD	
444771		100 Ohm	5,2 dB at 1MHz	60	96	-20 °C - +70 °C	-5 °C - +60 °C	9xD	15xD	
444982		100 Ohm	5,2 dB at 1 MHz	60	22 Power / 96 Bus	-40 °C - +70 °C	-20 °C - +60 °C	7,5xD	12xD	
<b>CAN-Bus</b>	444695	100-120 Ohm	46 dB at 3 MHz	55	87	-20 °C - +70 °C	-5 °C - +60 °C	7,5xD	15xD	
	444696	100-120 Ohm	46 dB at 3 MHz	55	87	-20 °C - +70 °C	-5 °C - +60 °C	7,5xD	15xD	
	444697	100-120 Ohm	46 dB at 3 MHz	55	82	-40 °C - +70 °C	-20 °C - +60 °C	7,5xD	15xD	
	444698	100-120 Ohm	46 dB at 3 MHz	55	82	-40 °C - +70 °C	-20 °C - +60 °C	7,5xD	15xD	
<b>Hybrid bus</b>	444742	150 Ohm	58 dB at 16 MHz	30	15 Power / 90 Bus	-40 °C - +70 °C	-20 °C - +60 °C	7,5xD	15xD	
	444794	not relevant	200 dB at 600 nm	-	15 Power	-40 °C - +70 °C	-20 °C - +60 °C	7,5xD	15xD	
<b>ASI Bus</b>	482101	not defined	not relevant	80	Klasse 6 acc. to EN 60228	-40 °C - +90 °C	-25 °C - +80 °C	7,5xD	10xD	
	482150	not defined	not relevant	80	Klasse 6 acc. to EN 60229	-40 °C - +80 °C	-25 °C - +70 °C	7,5xD	10xD	
	482160	not defined	not relevant	80	Klasse 6 acc. to EN 60230	-40 °C - +80 °C	-25 °C - +70 °C	7,5xD	10xD	
<b>Ethernet/Profinet</b> Profinet Type A Profinet Type B Profinet Type C	00749079	100 Ohm	8 dB at 16 MHz	50	55	-20 °C - +80 °C	0 °C - +60 °C	10	18xD	
		100 Ohm	12 dB at 16 MHz	50	55	-20 °C - +80 °C	0 °C - +60 °C	10	18xD	
		100 Ohm	12 dB at 16 MHz	50	55	-20 °C - +80 °C	0 °C - +60 °C	10	13xD	
<b>Devicenet</b> 1x2xAWG24+ 2xAWG22	49500307		21 dB at 1 MHz	37	87	-40 °C - +80 °C	-20 °C - +60 °C	7,5xD	15xD	
	49500306		14 dB at 1 MHz	37	25	-40 °C - +80 °C	-20 °C - +60 °C	7,5xD	15xD	
<b>Sensor cable</b>		not defined	-	not defined	-					

\* optional possible

No responsibility is taken for the correctness of this information, errors and errata excepted



# Technische Daten Busleitungen

Typ	Art.Nr.	Wellenwiderstand bei Frequenz	Dämpfung in dB/km	Kapazität pf/km	Leiterwiderstand Ohm per km	Temperaturbereich bewegt		Mindestbiegeradius fest verlegt	Mindestbiegeradius bewegt*/Installation
						fest verlegt	bewegt		
Profibus	444759	150 Ohm	42 dB at 16 MHz	30	55	-20 °C - +70 °C	-5 °C - +70 °C	10xD	18xD
	444779	150 Ohm	42 dB at 16 MHz	30	55	-20 °C - +70 °C	-5 °C - +70 °C	10xD	18xD
	444760	150 Ohm	42 dB at 16 MHz	30	55	-20 °C - +70 °C	-5 °C - +70 °C	10xD	18xD
	444762	150 Ohm	55 dB at 16 MHz	30	87	-40 °C - +70 °C	-20 °C - +60 °C	7,5xD	10xD
	444763	150 Ohm	55 dB at 16 MHz	30	87	-40 °C - +70 °C	-20 °C - +60 °C	7,5xD	10xD
	444739	150 Ohm	55 dB at 16 MHz	30	70	-40 °C - +70 °C	-20 °C - +60 °C	7,5xD	10xD
	444809	150 Ohm	55 dB at 16 MHz	30	70	-40 °C - +70 °C	-20 °C - +60 °C	7,5xD	10xD
	444775	150 Ohm	42 dB at 16 MHz	30	55	-20 °C - +70 °C	-5 °C - +70 °C	10xD	18xD
	444847	150 Ohm	42 dB at 16 MHz	30	55	-20 °C - +70 °C	-5 °C - +70 °C	10xD	18xD
	444821	150 Ohm	49 dB at 16 MHz	30	70	-40 °C - +70 °C	-20 °C - +60 °C	7,5xD	10xD
	444773	150 Ohm	42 dB at 16 MHz	30	55	-20 °C - +70 °C	-5 °C - +60 °C	10xD	18xD
	444816	150 Ohm	42 dB at 16 MHz	30	55	-20 °C - +70 °C	-5 °C - +60 °C	10xD	18xD
	444840	150 Ohm	42 dB at 16 MHz	30	55	-40 °C - +70 °C	-20 °C - +70 °C	10xD	18xD
	444841	150 Ohm	42 dB at 16 MHz	30	55	-40 °C - +70 °C	-20 °C - +70 °C	10xD	18xD
	444788	150 Ohm	55 dB at 16 MHz	30	84	-40 °C - +70 °C	-20 °C - +60 °C	7,5xD	10xD
	444848	150 Ohm	55 dB at 16 MHz	30	84	-40 °C - +70 °C	-20 °C - +60 °C	7,5xD	10xD
Profibus PA	444734	100 Ohm	3 dB at 39 kHz	55	22	-20 °C - +70 °C	-5 °C - +60 °C	9xD	18xD
Interbus	444764	100 Ohm	2,7 dB at 1MHz	60	96	-40 °C - +70 °C	-20 °C - +60 °C	7,5xD	10xD
	444765	100 Ohm	2,7 dB at 1MHz	60	96	-20 °C - +70 °C	-5 °C - +70 °C	7,5xD	15xD
	444771	100 Ohm	5,2 dB at 1MHz	60	96	-20 °C - +70 °C	-5 °C - +60 °C	9xD	15xD
	444982	100 Ohm	5,2 dB at 1 MHz	60	22 Power / 96 Bus	-40 °C - +70 °C	-20 °C - +60 °C	7,5xD	12xD
CAN-Bus	444695	100-120 Ohm	46 dB at 3 MHz	55	87	-20 °C - +70 °C	-5 °C - +60 °C	7,5xD	15xD
	444696	100-120 Ohm	46 dB at 3 MHz	55	87	-20 °C - +70 °C	-5 °C - +60 °C	7,5xD	15xD
	444697	100-120 Ohm	46 dB at 3 MHz	55	82	-40 °C - +70 °C	-20 °C - +60 °C	7,5xD	15xD
	444698	100-120 Ohm	46 dB at 3 MHz	55	82	-40 °C - +70 °C	-20 °C - +60 °C	7,5xD	15xD
Hybridbusleitung	444742	150 Ohm	58 dB at 16 MHz	30	15 Power / 90 Bus	-40 °C - +70 °C	-20 °C - +60 °C	7,5xD	15xD
	444794	not relevant	200 dB at 600 nm	-	15 Power	-40 °C - +70 °C	-20 °C - +60 °C	7,5xD	15xD
ASI Bus	482101	not defined	not relevant	80	Klasse 6 acc. to EN 60228	-40 °C - +90 °C	-25 °C - +80 °C	7,5xD	10xD
	482150	not defined	not relevant	80	Klasse 6 acc. to EN 60229	-40 °C - +80 °C	-25 °C - +70 °C	7,5xD	10xD
	482160	not defined	not relevant	80	Klasse 6 acc. to EN 60230	-40 °C - +80 °C	-25 °C - +70 °C	7,5xD	10xD
Ethernet/Profinet	Profinet Type A	100 Ohm	8 dB at 16 MHz	50	55	-20 °C - +80 °C	0 °C - +60 °C	10	18xD
	Profinet Type B	100 Ohm	12 dB at 16 MHz	50	55	-20 °C - +80 °C	0 °C - +60 °C	10	18xD
	Profinet Type C	100 Ohm	12 dB at 16 MHz	50	55	-20 °C - +80 °C	0 °C - +60 °C	10	13xD
Devicenet	1x2xAWG24+ 2xAWG22								
	49500307		21 dB at 1 MHz	37	87	-40 °C - +80 °C	-20 °C - +60 °C	7,5xD	15xD
1x2xAWG18+ 2xAWG15	49500306		14 dB at 1 MHz	37	25	-40 °C - +80 °C	-20 °C - +60 °C	7,5xD	15xD
Sensorleitung		not defined	-	not defined	-				

\* optional möglich

Alle Angaben ohne Gewähr; Irrtum und Druckfehler vorbehalten.

# Checklist for enquiries

## Anfragencheckliste

**Fax +49 (0)911 5207-248**

Company <i>Firma</i>				Contact <i>Ansprechpartner</i>		Telephone <i>Fax</i>		eMail	
Quantity in km <i>Menge in km</i>	Article description (construction: cross section, shielding ...) <i>Artikelbezeichnung (Aufbau: Querschnitt, Paarzahl, Schirmung usw.)</i>					Targetprice EUR/km <i>Zielpreis EUR/km</i>		Colour or RAL no. <i>Farbe oder RAL-Nr.</i>	
Sheath printing: <i>Bedruckungstext:</i>									
Core colours: <i>Aderfarben:</i>									
Customers datasheet enclosed / <i>Kunden-Datenblatt als Anlage</i>						<input type="checkbox"/> yes / <i>ja</i>		<input type="checkbox"/> no / <i>nein</i>	

### Specifications / Normen

The cable has to fulfill following national/international specifications: <i>Die Leitung muss folgenden nationalen/internationalen Normen entsprechen:</i>				
<input type="checkbox"/> VDE	or / <i>oder</i>	<input type="checkbox"/> VDE-Reg. Nr.	<input type="checkbox"/> UL/cULus	<input type="checkbox"/> CSA
<input type="checkbox"/> other, e.g. customer specifications / <i>sonstige, z.B. Kunden-Normen:</i>				

### Electrical properties / Elektrische Eigenschaften

Working voltage / <i>Betriebsspannung:</i>							
power:	<input type="checkbox"/> < 50 V	<input type="checkbox"/> 300/300 V	<input type="checkbox"/> 300/500 V	<input type="checkbox"/> 450/750 V	<input type="checkbox"/> 0,6/1 kV	<input type="checkbox"/> > 1 kV	
signal:	<input type="checkbox"/> < 50 V	<input type="checkbox"/> 300/300 V	<input type="checkbox"/> 300/500 V	<input type="checkbox"/> 450/750 V	<input type="checkbox"/> 0,6/1 kV	<input type="checkbox"/> > 1 kV	
Mutual capacity / <i>Betriebskapazität</i> (nF/km = pf/m):							
<b>For data/bus cables / Für Daten-/Bus-kabel:</b>							
Characteristic impedance / <i>Wellenwiderstand</i> ( $\Omega$ ):				at frequency / <i>bei Frequenz</i> (MHz):			
Attenuation / <i>Dämpfung</i> (dB):				Near end cross talk / <i>Nebensprechdämpfung</i> (db):			
Screen attenuation / <i>Schirmdämpfung</i> (dB):							

### Thermal properties / Thermische Eigenschaften

Max. operating temperature / <i>max. Betriebstemperatur:</i>							
<input type="checkbox"/> 60 °C	<input type="checkbox"/> 70 °C	<input type="checkbox"/> 80 °C	<input type="checkbox"/> 90 °C	<input type="checkbox"/> > 90 °C :	°C		
At duration / <i>bei Zeitdauer:</i>							
<input type="checkbox"/> 20 000 h	<input type="checkbox"/> 3 000 h	<input type="checkbox"/> 48 h	<input type="checkbox"/> or / <i>oder</i>	h			
Min. operating temperature / <i>min. Betriebstemperatur:</i>							
<input type="checkbox"/> - 50 °C	<input type="checkbox"/> - 40 °C	<input type="checkbox"/> or / <i>oder</i>	°C				
At use / <i>bei Einsatz:</i>							
<input type="checkbox"/> fix installed / <i>fest verlegt</i>				<input type="checkbox"/> moved / <i>bewegt</i>			

### Chemical properties / Chemische Eigenschaften

<input type="checkbox"/> No special requirements / keine besonderen Anforderungen <input type="checkbox"/> Resistant against - exposure time and temperature - humidified or dipped: <i>Beständig gegen - Einwirkungsdauer und Temperatur - benetzt oder eingetaucht:</i>
---

### Fire properties / Eigenschaften im Brandfall

halogenfree / halogenfrei	<input type="checkbox"/> yes / ja	<input type="checkbox"/> no / nein	Toxicity / Toxizität	<input type="checkbox"/> yes / ja	<input type="checkbox"/> no / nein
firetest acc. / Brandprüfung nach:	<input type="checkbox"/> IEC 332-1 Prüfmethode B (Cable / Leitung) <input type="checkbox"/> IEC 332-2 Prüfmethode A (Cores / Adern) <input type="checkbox"/> IEC 332-3 Bundle / Bündel (Cable / Leitung)				

### Other requirements, e.g. cable processing or delivery form Sonstige Forderungen, z. B. Verarbeitung der Leitung oder Lieferaufmachung

--

### Mechanical properties / Mechanische Eigenschaften

<input type="checkbox"/> fix installed / fest verlegt	<input type="checkbox"/> flexible installed / flexibel verlegt: min. bending radius / min. Biegeradius	mm
<input type="checkbox"/> chainable acc. to SFK (chain capability class): see page 5 / Schleppleitung nach SFK Schlepp-Fähigkeits-Klasse: siehe Seite 5		
<input type="checkbox"/> standard requirements "SFK 4" / Standard-Anforderung „SFK 4“		
<input type="checkbox"/> stronger requirements "SFK 6" / verschärfte Anforderung „SFK 6“		
<b>special requirements / spezielle Anforderungen</b>		
min. bending radius / kleinster Biegeradius:		mm
displacement / Verfahrweg:		m
max. displacement velocity / max. Verfahrgeschwindigkeit:		m/min.
max. acceleration / max. Beschleunigung:		m/sec <sup>2</sup>
numbers of cycles / Anzahl der Zyklen:		Mio.
<b>Robotcable / Roboterleitungen</b>		
<input type="checkbox"/> torsion / Torsion	torsion angle / Torsionswinkel:	° per meter cable / je Meter Leitung
<input type="checkbox"/> torsion and bending / Biegung und Torsion		min. bending radius / min. Biegeradius:
<input type="checkbox"/> tensile-loaded capacity / Zugbelastbarkeit gefordert:		Newton



# C E R T I F I C A T E

## DQS GmbH

Deutsche Gesellschaft zur Zertifizierung von Managementsystemen

hereby certifies that the company

### Nexans Deutschland Industries GmbH & Co. KG

Business Unit Nürnberg

Sieboldstraße 10  
90411 Nürnberg

for the scope

Design, development, production and sales of  
special cables for energy-, control- and signaltransmission  
with logistics by Nexans Logistik GmbH, Nürnberg

has implemented and maintains a

### Quality Management System.

An audit, documented in a report, has verified that this  
quality management system fulfills the requirements  
of the following standard:

### DIN EN ISO 9001 : 2000

December 2000 edition

This certificate is valid until 2011-04-01

Certificate Registration No. 000848 QM

Frankfurt am Main 2008-04-02

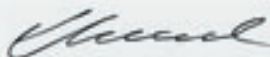

Ass. iur. M. Drechsel

MANAGING DIRECTORS



Dipl.-Ing. S. Heinoth



D-60433 Frankfurt am Main, August-Schanz-Straße 21





# Z E R T I F I K A T

Die

**DQS GmbH**

Deutsche Gesellschaft zur Zertifizierung von Managementsystemen

bescheinigt hiermit, dass das Unternehmen

**Nexans Deutschland Industries GmbH & Co. KG**

**Business Unit Nürnberg**

Sieboldstraße 10  
90411 Nürnberg

für den Geltungsbereich

Entwicklung, Herstellung und Vertrieb von  
Spezialkabel und -leitungen für Energie-, Steuer- und Signalübertragung  
mit Logistik bei Nexans Logistik GmbH, Nürnberg

ein

**Qualitätsmanagementsystem**

eingeführt hat und anwendet.

Durch ein Audit, dokumentiert in einem Bericht, wurde der  
Nachweis erbracht, dass dieses Qualitätsmanagementsystem  
die Forderungen der folgenden Norm erfüllt:

**DIN EN ISO 9001 : 2000**

Ausgabe Dezember 2000

Dieses Zertifikat ist gültig bis 2011-04-01

Zertifikat-Registrier-Nr. 000848 QM

Frankfurt am Main 2008-04-02

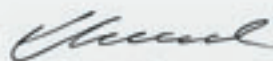

Ass. iur. M. Drechsel

GESCHÄFTSFÜHRER



Dipl.-Ing. S. Heiniath



D-60433 Frankfurt am Main, August-Schanz-Straße 21





THE INTERNATIONAL CERTIFICATION NETWORK

# CERTIFICATE

**IQNet** and  
**DQS GmbH** Deutsche Gesellschaft zur Zertifizierung von Managementsystemen  
 hereby certify that the company

**Nexans Deutschland Industries GmbH & Co. KG**  
**Business Unit Nürnberg**

Sieboldstraße 10  
 90411 Nürnberg

for the scope

Design, development, production and sales of  
 special cables for energy-, control- and signaltransmission  
 with logistics by Nexans Logistik GmbH, Nürnberg

has implemented and maintains a

## Quality Management System.

An audit, documented in a report, has verified that  
 this quality management system fulfills the requirements  
 of the following standard:

### ISO 9001 : 2000

This certificate is valid until 2011-04-01

Frankfurt am Main 2008-04-02

Registration Number: DE-000848 QM



*R. Wasmer*  
 René Wasmer  
 President of IQNet

*M. Drechsel*  
 Ass. iur. M. Drechsel  
 Managing Directors of DQS GmbH

*S. Heinloth*  
 S. Heinloth  
 Managing Directors of DQS GmbH



IQNet Partners\*:

AENOR Spain AFAQ AFNOR France AIB-Vinçotte International Belgium ANCE Mexico APCER Portugal CISQ Italy CQC China  
 CQM China CQS Czech Republic Cro Cert Croatia DQS Germany DS Denmark ELOT Greece FCAV Brazil  
 FONDONORMA Venezuela HKQAA Hong Kong China ICONTEC Colombia IMNC Mexico Inspecta Certification Finland  
 IRAM Argentina IQA Japan KFQ Korea MSZT Hungary Nemko AS Norway NSAI Ireland PCBC Poland  
 Quality Austria Austria RR Russia SAI Global Australia SII Israel SIQ Slovenia SIRIM QAS International Malaysia  
 SQS Switzerland SRAC Romania TEST St Petersburg Russia YUQS Serbia

IQNet is represented in the USA by: AFAQ AFNOR, CISQ, DQS, NSAI Inc. and SAI Global

\* The list of IQNet partners is valid at the time of issue of this certificate. Updated information is available under [www.ignet-certification.com](http://www.ignet-certification.com)



# C E R T I F I C A T E

## DQS GmbH

Deutsche Gesellschaft zur Zertifizierung von Managementsystemen

hereby certifies that the company

### Nexans Deutschland Industries GmbH & Co. KG Business Unit Nürnberg

Sieboldstraße 10  
90411 Nürnberg

for the scope

Design, development and production of special cables for energy-, control- and signaltransmission  
with logistics by Nexans Logistik GmbH, Nürnberg

has implemented and maintains a

### Quality Management System.

An audit, conducted in accordance with the "Rules for certification bodies to ISO/TS 16949:2002 Second Edition"  
and documented in a report, has verified that this quality management system fulfills the requirements  
of the following ISO Technical Specification:

### ISO/TS 16949:2002

Second Edition March 2002

(with product design)

Certification audit	2008-02-18 – 2008-02-21
Certification decision	2008-04-02
This certificate is valid until	2011-04-01
Certificate Registration No.	000848 TS2
IATF No.	0066077
Issued in Frankfurt am Main, Germany	2008-04-02

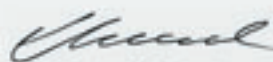

Ass. iur. M. Drechsel

MANAGING DIRECTORS



Dipl.-Ing. S. Heinieth

60433 Frankfurt am Main, August-Schanz-Straße 21  
(Tel. +49-69-95 42 70), Germany

2-IAO-QMC-01001



# Z E R T I F I K A T

Die

## DQS GmbH

Deutsche Gesellschaft zur Zertifizierung von Managementsystemen

bescheinigt hiermit, dass das Unternehmen

### Nexans Deutschland Industries GmbH & Co. KG Business Unit Nürnberg

Sieboldstraße 10  
90411 Nürnberg

für den Geltungsbereich

Entwicklung und Herstellung von Spezialkabel und -leitungen für Energie-, Steuer- und Signalübertragung  
mit Logistik bei Nexans Logistik GmbH, Nürnberg

ein

### Qualitätsmanagementsystem

eingeführt hat und anwendet.

Durch ein Audit, dokumentiert in einem Bericht, wurde in Übereinstimmung  
mit den „Zertifizierungsvorgaben der Automobilindustrie für ISO/TS 16949:2002, 2. Auflage“  
der Nachweis erbracht, dass dieses Qualitätsmanagementsystem die Forderungen  
der folgenden Technischen Spezifikation erfüllt:

### ISO/TS 16949:2002

2. Ausgabe März 2002

(mit Produktentwicklung)

Zertifizierungsaudit	2008-02-18 – 2008-02-21
Zertifizierungsentscheidung	2008-04-02
Dieses Zertifikat ist gültig bis	2011-04-01
Zertifikat-Registrier-Nr.	000848 TS2
IATF-Nr.	0066077
Frankfurt am Main	2008-04-02

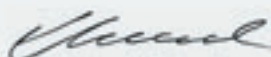

Ass. iur. M. Drechsel

GESCHÄFTSFÜHRER



Dipl.-Ing. S. Heinkoth

D-60433 Frankfurt am Main, August-Schanz-Straße 21  
(Tel. +49-69-95 42 70)

2-IAO-QMC-01001





# C E R T I F I C A T E

The  
**DQS GmbH**  
Deutsche Gesellschaft zur Zertifizierung von Managementsystemen  
hereby certifies that the company

## **Nexans Deutschland Industries GmbH & Co. KG**

**Business Unit Nürnberg**  
Sieboldstraße 10  
90411 Nürnberg

for the product categorie

Cabling and Cabinets

12

has implemented and maintains a Quality Management System.  
An audit, documented in a report, has verified that this quality management system  
fulfills the requirements of the following standard:

### **International Railway Industry Standard (IRIS) Revision 00, March 2006**

Certification audit	2007-03-05 – 2007-03-08
Certification decision	2007-03-21
This certificate is valid until	2010-03-20
Certificate Registration No.	000848 IRIS
Issued in Frankfurt am Main, Germany	2007-03-21

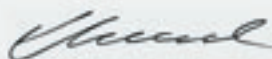

Ass. iur. M. Drechsel

MANAGING DIRECTORS



Dipl.-Ing. S. Heintoth



D-60433 Frankfurt am Main, August-Schanz-Straße 21



# Z E R T I F I K A T

Die

**DQS GmbH**

**Deutsche Gesellschaft zur Zertifizierung von Managementsystemen**

bescheinigt hiermit, dass das Unternehmen

**Nexans Deutschland Industries GmbH & Co. KG**

**Business Unit Nürnberg**

Sieboldstraße 10

90411 Nürnberg

für den Geltungsbereich

Verkabelung und Schaltschränke

12

ein Qualitätsmanagementsystem eingeführt hat und anwendet.  
Durch ein Audit, dokumentiert in einem Bericht, wurde der Nachweis erbracht,  
dass das Managementsystem die Forderungen des folgenden Regelwerkes erfüllt:

**International Railway Industry Standard (IRIS)**

**Revision 00, März 2006**

Auditdatum 2007-03-05 – 2007-03-08

Zertifizierungsentscheidung 2007-03-21

Dieses Zertifikat ist gültig bis 2010-03-20

Zertifikat-Registrier-Nr. 000848 IRIS

Frankfurt am Main 2007-03-21

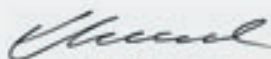

Ass. iur. M. Drechsel

GESCHÄFTSFÜHRER



Dipl.-Ing. S. Heintoth

**IRIS**  
Certification

D-60433 Frankfurt am Main, August-Schanz-Straße 21



Global expert in cables and cabling systems

Nexans Deutschland GmbH  
Sieboldstraße 10 · 90411 Nürnberg · Tel. +49 (0)911 5207-239 · Fax +49 (0)911 5207-248  
[www.nexans.de](http://www.nexans.de)