

Concealed Gate Closer

The Concealed Gate Closer is cleverly designed to minimise the amount of gate closer that is visible. It fits inside the top, middle or bottom horizontal gate rail of a 40mm steel box section (1 37/64") gate frame or in a channel cut into the top or bottom of a timber gate. When the gate is closed, the closer is barely visible and completely avoids the need to place brackets on the face of the gate frame. This closer is the ideal choice when appearance is important.

Hydraulic control of the gate closer's closing speed is fully adjustable by using a long reach hexagon (Allen) key which is placed into the slot in the polymer shroud shown in the following pages.

To fit the closer, the gate must be removed and suitable threaded holes made in the gate and post to take the closer. With timber gates, a channel needs to be made with a router or other tool to accept the closer in the top or bottom rail of the gate.

As with most gate closers, a restricting stop should be fitted to avoid damage to the closer and the gate closer should be allowed to close the gate and the gate should not be pushed or pulled close.



Material	Bright zinc plated steel
Closing speed	Fully adjustable
Gate suitability	Steel, aluminium or wood
Max. opening angle	90°
Max. gate width	1150mm (45")
Max. gate height	2500mm (98")
Max. gate weight	80kg (176 lbs)

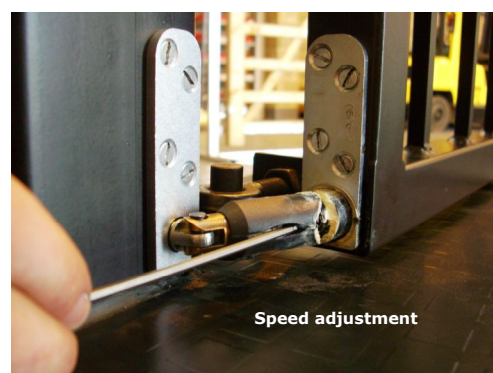

Selecting a Concealed Gate Closer

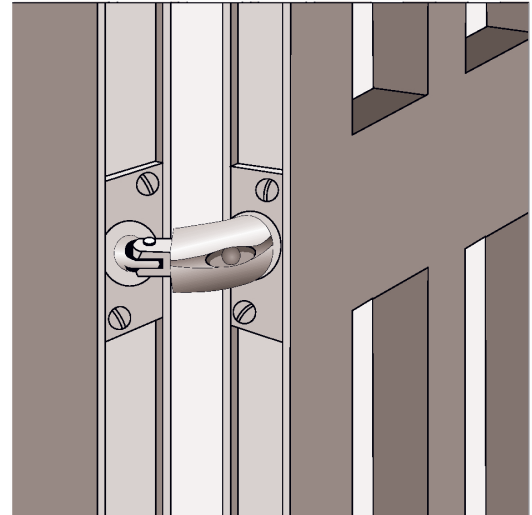
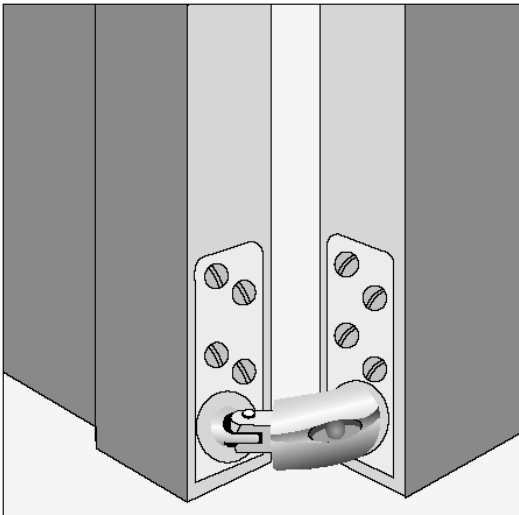

To select the correct gate closer simply decide the position where the gate closer is to be fitted, select the correct gate closer reference from those in the drawing below and then place your order. The mid-rail gate closer (reference GATECLOSER011) is not handed and can be fitted in any position. The other two closers are handed and can only be fitted in the positions indicated.

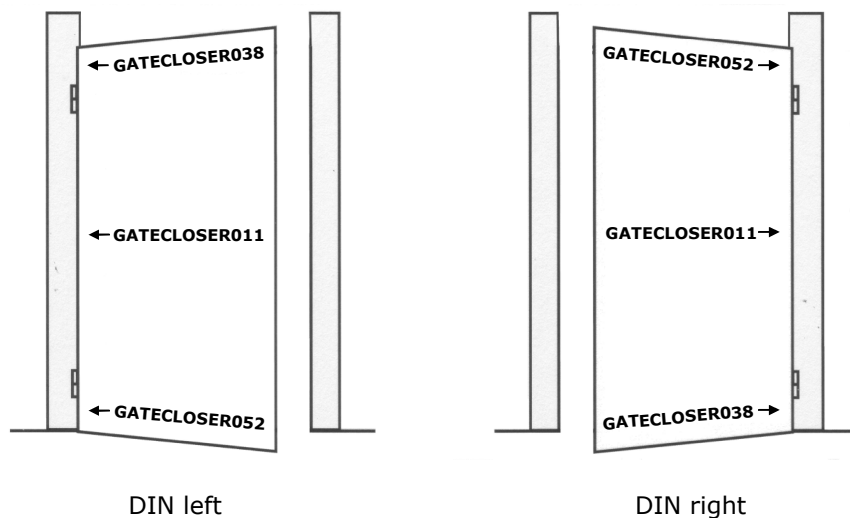

GATECLOSER 038	Concealed closer — fit top left & bottom right
GATECLOSER 011	Concealed closer — fit mid-rail
GATECLOSER 052	Concealed closer — fit top right & bottom left

Concealed Gate Closer Fitting Dimensions

W	3/8" - 13/16"
X	1.3/8" - 1.13/16"
Y	1/16" - 9/16"

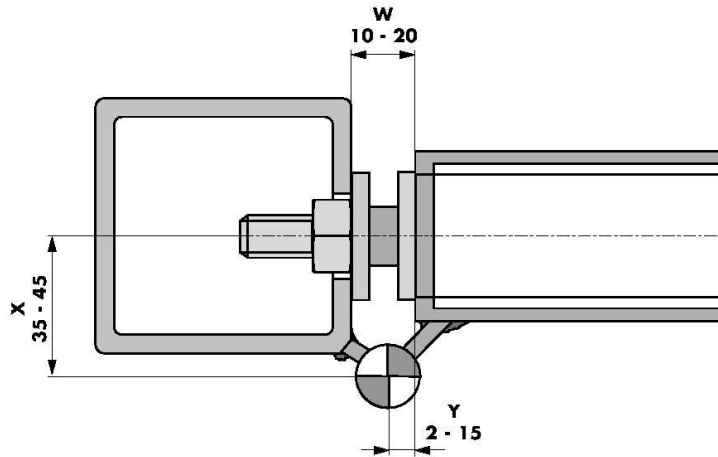

W	1/16" - 1/2"
X	1.3/8" - 1.13/16"
Y	1/16" - 9/16"

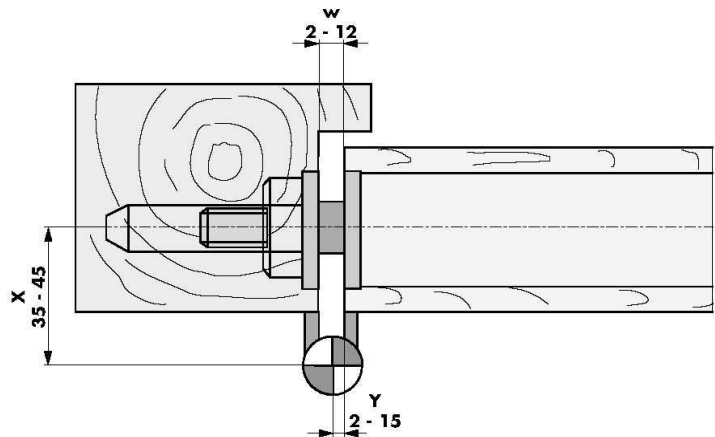

3mm	1/8"
5mm	3/16"
7mm	1/4"
27mm	1.1/16"
30mm	1.3/16"
35mm	1.3/8"
40mm	1.9/16"
44mm	1.3/4"
46mm	1.13/16"
78mm	3.3/16"

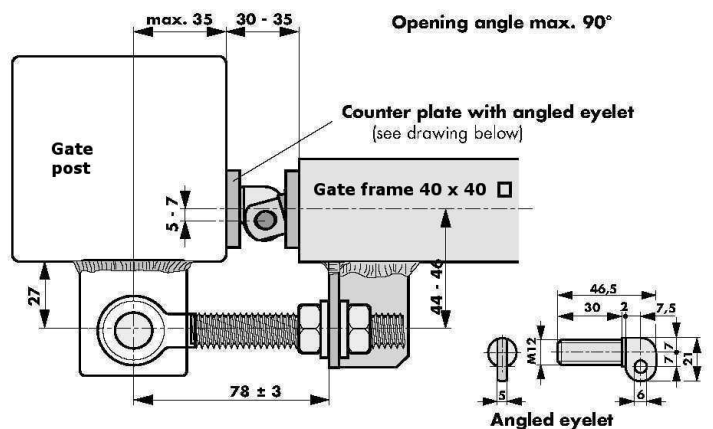

*Conversions to practical fraction equivalents

Concealed Gate Closer Dimensions

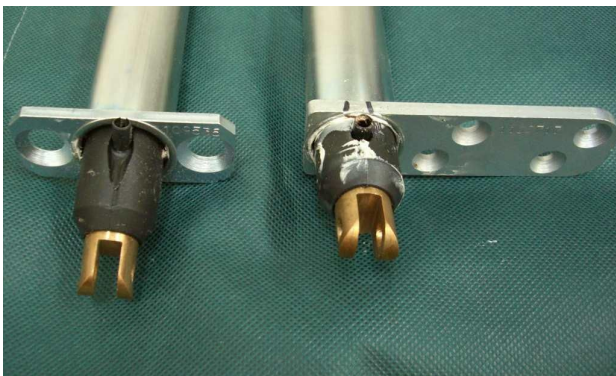
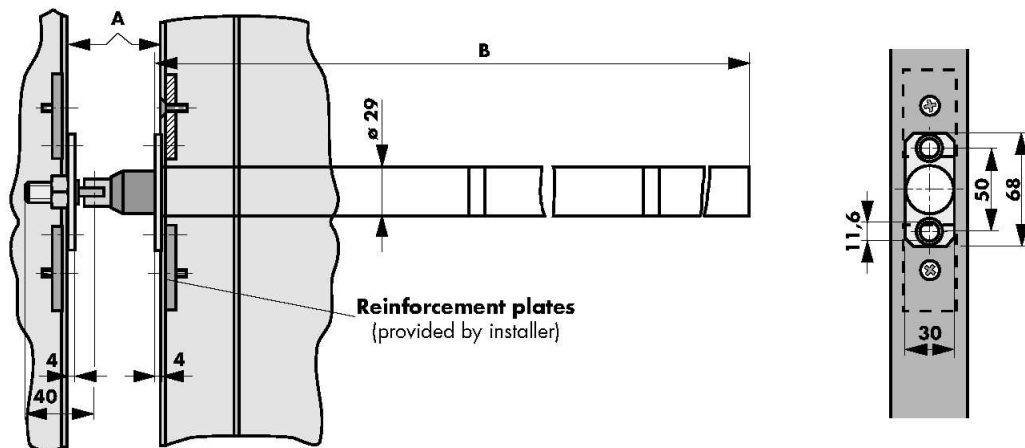

4mm	3/16"	31mm	1.1/4"
5mm	3/16"	50mm	2"
6.1mm	1/4"	68mm	2.11/16"
10mm	3/8"	85mm	3.3/8"
11.6	7/16"	101mm	4"
14mm	9/16"	"B" 734mm	28.7/8"
29mm	1.3/16"		*Conversions to practical fraction equivalents
30mm	1.3/16"		

