

THE LHS GUIDE MAST IS SUPPORTED BY A SINGLE BASE PLATE.

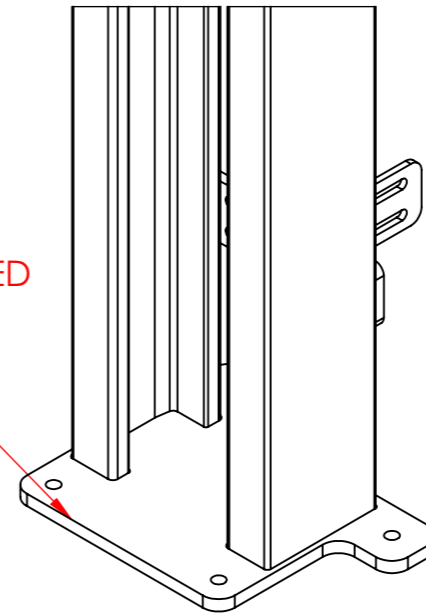

**DETAIL B  
SCALE 1 : 5**

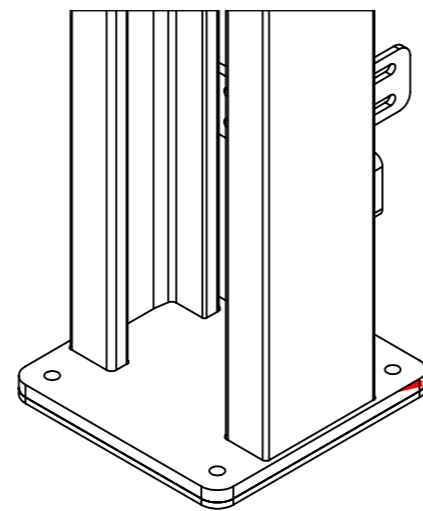

**DETAIL A  
SCALE 1 : 5**

THE RHS GUIDE MAST IS SUPPORTED BY THE BASE PLATE OF THE WELDED MAST AND A SPACER PLATE TO ALLOW THE MAIN BASE PLATE TO SIT ON TOP OF THE EXISTING STEELWORK. AS A RESULT OF THE SPACER PLATE THE TOP OF THE RHS GUIDE MAST WILL SIT 5mm HIGHER THAN THE LHS.

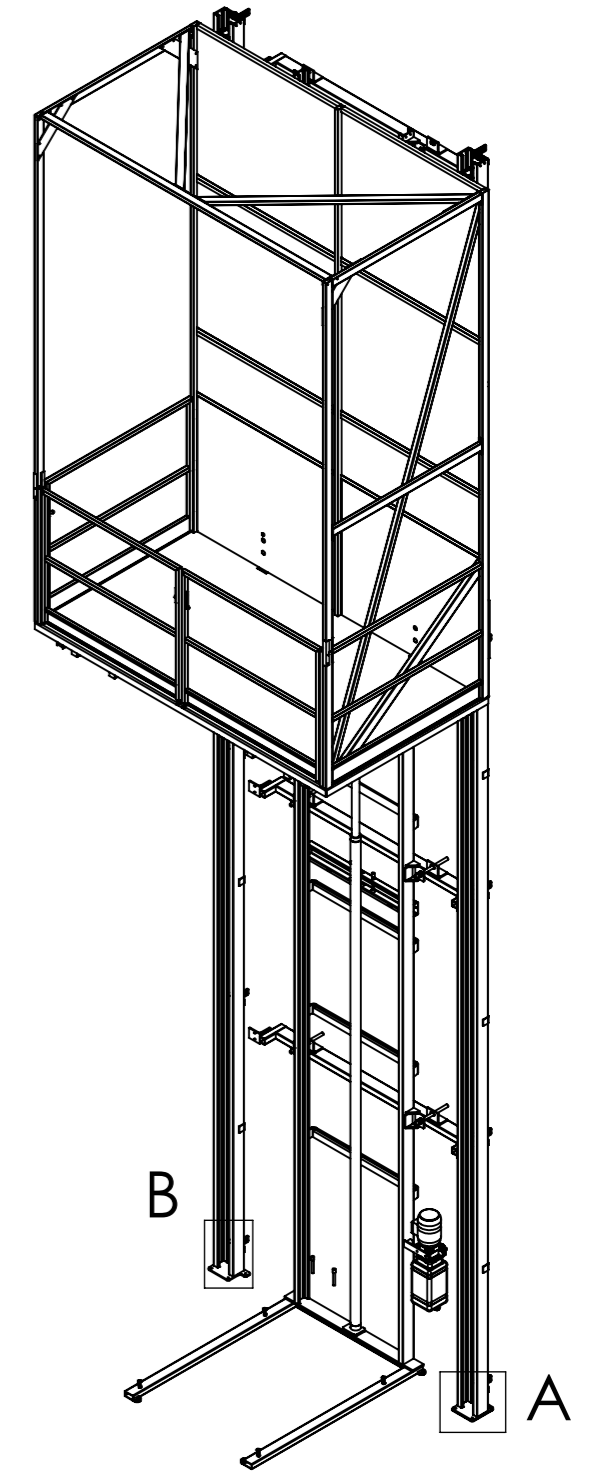

ALL DIMENSIONS IN mm, GENERAL TOLERANCE OF 0.5mm UNLESS OTHERWISE SPECIFIED THIS DRAWING FORMS PART OF A REGISTERED DESIGN

-		XX.XX.XX
-	Manual Handling Solutions 58, Paige Close, Watlington, Kings Lynn, Norfolk PE33 0TQ Tel 01553 811977 Fax 01553 811004	XX.XX.XX
-	sales@manualhandlingsolutions.co.uk www.manualhandlingsolutions.com	XX.XX.XX
ISSUE	DESCRIPTION	

PART No: SP-NT-MZL-14644A		No. OFF.
PART NAME: MEZZANINE FLOOR GOODS LIFT, 500KG CAPACITY		1
MATERIAL: AS PER INDIVIDUAL ITEMS	DRN BY: SPC	
FINISH: N/A	DRN: 14/11/2011	
DRAWING. No: D-SP-NT-MZL-14644A-A	SCALE: 1:50	
	ORIGINAL SHEET SIZE:	
	<b>A3</b>	