



# Hazardous Cabinets

COSHH Regulations demand the safe storage of hazardous items. These Cabinets isolate flammable materials and vapours from potential sources of ignition and clearly identify hazardous products in case of a fire.



- Robust durable construction
- Reinforced doors
- Removable 75mm sealed sump base tray
- Supplied with adjustable 85kg shelves
- All units comply with HFL/LPG Reg 1972 Sec 5. HSE The Storage of Flammable Containers HS(G)51
- Working towards many of the principals outlined in DSEAR Regs. 2002
- High visibility 270 degree labelling conforming to BS5609

Supplied with Smoke/Fire alarm fitted internally



## INTERNAL COMPARTMENTS

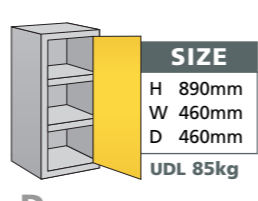
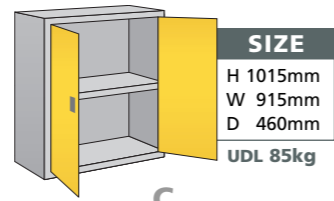
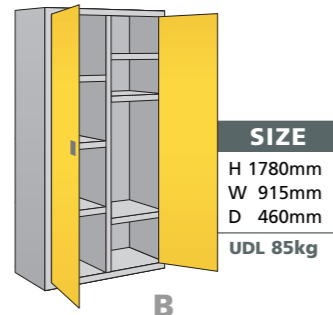
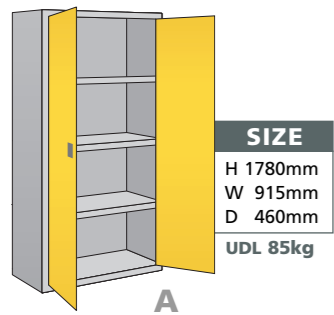

**DD**  
Dished top version available  
Includes rubber mat

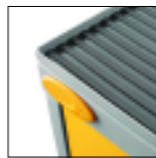

# Medical Cabinets



- Strong robust construction
- All Cabinets feature adjustable shelves
- Two point locking on all two door Cabinets
- High visibility 270 degree labelling complying to BS5499-1
- Reinforced doors for extra strength
- Range of 7 models

Under the Health and Safety Regulations 1981, workplaces must have first aid provision. To satisfy a wide range of first aid equipment we have designed an attractive and highly visible range of Probe Cabinets for your working environment.



**W PERSONAL LOCKER**  
Including top shelf and coat hook

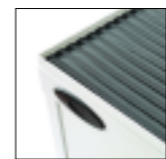

**UD PERSONAL LOCKER**  
Including top shelf and coat hook

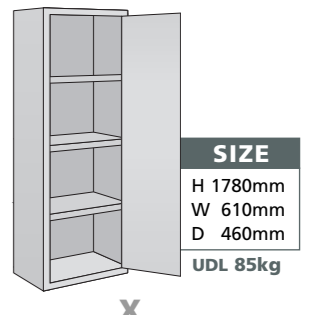
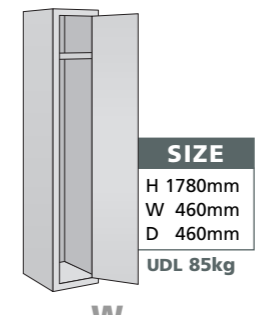
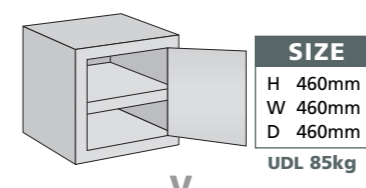
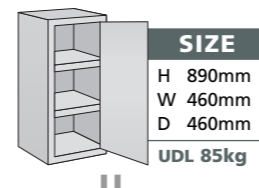

We reserve the right to alter designs and specification of products illustrated in this brochure without prior consent. All sizes are nominal. All information is correct at time of going to press.

# Acid/Alkaline Cabinets

The storage of caustic materials needs to be controlled. These Cabinets will allow the safe storage of acids and alkalis in a range of highly visible Probe Cabinets.



- Durable epoxy polyester coating giving a surface resistant to most acids and alkalis
- Strong steel construction
- Two point locking on all two door Cabinets
- Removable 75mm sealed sump base tray
- High visibility 270 degree labelling complying to BS5499-1
- All Cabinets feature adjustable shelves

Smoke / Fire alarm fitted internally

## INTERNAL COMPARTMENTS

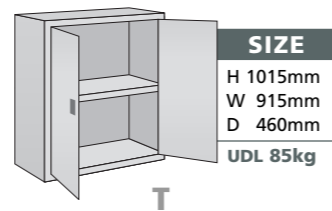
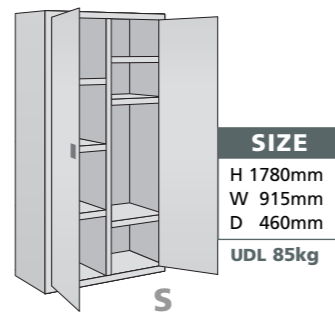

# Toxic Cabinets



- Strong robust construction
- All Cabinets feature adjustable shelves
- Two point locking on all two door Cabinets
- Removable 75mm sealed sump base tray
- High visibility 270 degree labelling complying to BS5609

This range of Probe Cabinets will allow Toxic materials to be clearly identified, handled and stored correctly.

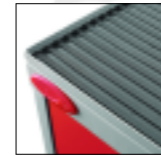

ED  
Dished top version available  
Includes rubber mat

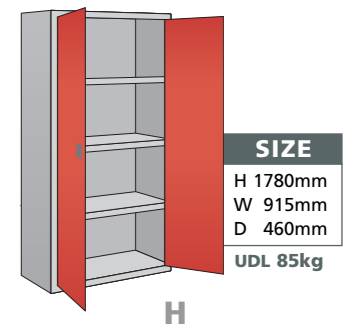
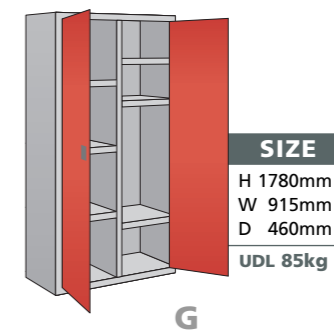
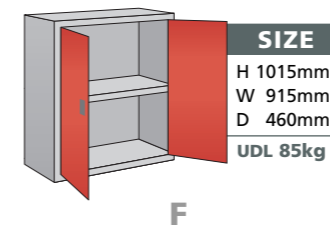
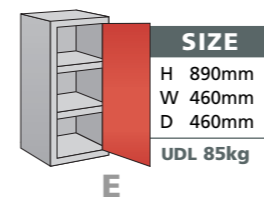

We reserve the right to alter designs and specification of products illustrated in this brochure without prior consent. All sizes are nominal. All information is correct at time of going to press.

# PPE Cabinets

Personal Protection Equipment is mandatory in many working environments (PPE at Work Regulations 1992 Part 5). Controlling and storing your safety equipment will be more effective in a specially designed Probe PPE Cabinet.

- All Cabinets feature adjustable shelves
- Strong robust construction
- Two point locking on all two door Cabinets
- High visibility 270 degree labelling complying to BS5499-1
- Reinforced doors for extra strength
- Range of 5 models



## INTERNAL COMPARTMENTS

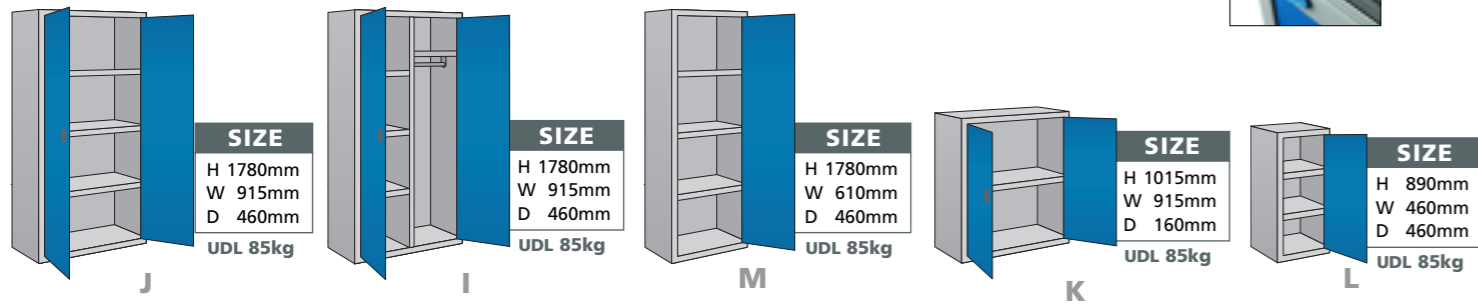

Dished top version available  
Includes rubber mat

LD

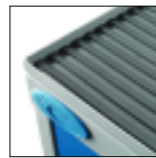

# General Cabinets



- Strong robust construction
- Designed to comply with COSHH Regs
- All Cabinets feature adjustable shelves
- Two point locking on all two door Cabinets
- Removable 75mm sealed sump base tray
- High visibility 270 degree labelling complying to BS5609

To satisfy your own particular hazard or warning we have designed a range of special Cabinets which meet high standards of storage safety. Labelling is supplied for you to personalise your particular hazard.

Smoke/Fire alarm fitted internally



Self Write Labels

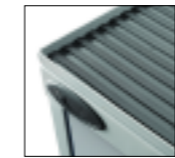

ND

Dished top version available  
Includes rubber mat

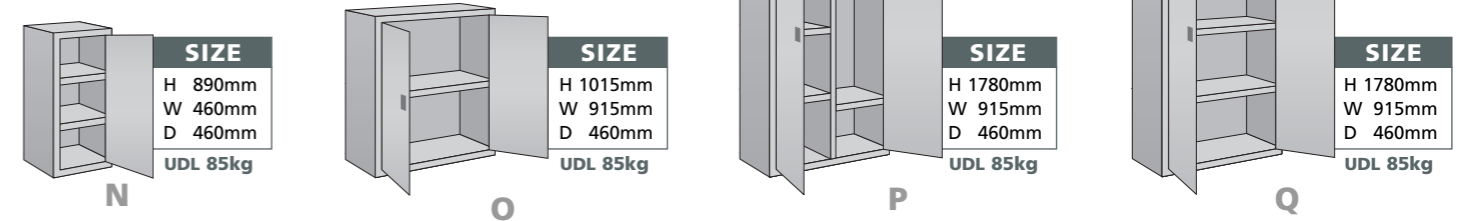

We reserve the right to alter designs and specification of products illustrated in this brochure without prior consent. All sizes are nominal. All information is correct at time of going to press.

# storwell

■ ■ ■ S Y S T E M S



*More storage in less space*

Working with a specialist partner with over 28 years experience in the storage sector is just one reason why you can trust Storwell Systems with your enquiries.

We are **objective, non-tied, independent, and impartial** and continually researching all the leading UK manufacturers for product quality and innovation; only selecting those companies whose **integrity, design** and **product range** are the best in the industry so... you don't need to.

You can be sure you will get impartial advice, the best prices and delivery times and a dedicated project manager giving you all the technical support you need for complete peace of mind.



T: 01527 592444 F: 01527 592727  
E: [sales@storwellsystems.co.uk](mailto:sales@storwellsystems.co.uk)  
W: [www.storwelldirect.co.uk](http://www.storwelldirect.co.uk)