

Function

KANON's Folding Stairs are used worldwide to achieve safe and easy access of road and rail tankers from a platform.

Description

As KANON promotes safe and easy solutions, our concept includes the following features:

- Easy handling by one operator.
- Handrails fitted as standard.
- Locking device for stored position (only for manual operation)
- Rubber bumper on last step, preventing sparks and tanker damage.
- Movable safety step to prevent trapped feet.
- Non slip steps.
- Access width of 800 mm upto 4000 mm.
- Fully balanced in any position.
- Maintenance free rotation joints.
- Pull rope to reduce forces needed to get folding stairs in stored position.
- Knee guides.

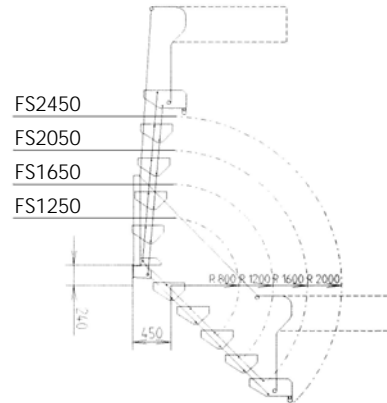
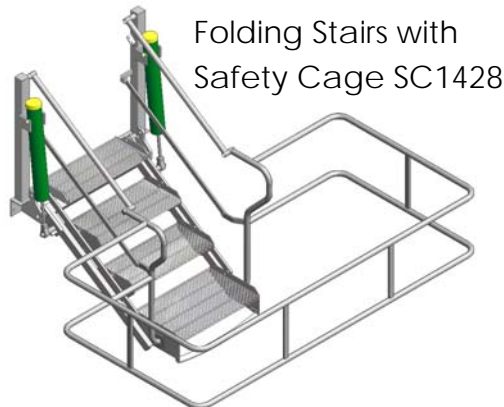

Accessories

- Safety cages 1400 x 1400 and 1400 x 2800 (other on request upto 12 m).
- Safety wings on both sides of the stairs to close the opening between platform and vehicle.
- All stairs are suitable for pneumatic or hydropneumatic operation.
- All stairs are designed to be equipped with a safety cage if it's required afterwards.
- A retrofit in a later stage is possible.
- Position detection.
- Movable alongside the platform.
- Galvanised execution.
- Locking chain, to hold stair in any position and prevent damage to insulation on tanker.