



Pharmatech
Innovation in Pharmaceutical Engineering

Hoists & Lifters

Hoists



Pharmalift Hoists

2

Introduction



The GMP Way of Making Life Easy

Pharmatech hoists offer the ideal way to construct gravity feed systems. Simply lift the container, position and discharge.

- No additional equipment to clean
- Simple effective dust-tight connections
- Accurate positioning
- Cost effective

Hoist Features

- GMP Correct construction
- Modular Design
- CE Marked
- Any height up to 17m
- Any load up to 4 tonnes

Built To Your Exact Requirements

Pharmatech offer a wide range of hoists for a variety of applications. Designs are customised to individual requirements.

This brochure shows a wide range of applications. If you have any questions or require further assistance please contact us.

- Static or mobile machines
- Drum handling systems
- IBC handling systems
- Special container systems
- Can lift machines eg. mills, sieves, vacuum transfer
- Ex rated to any standard
- Space saving hoist blender systems

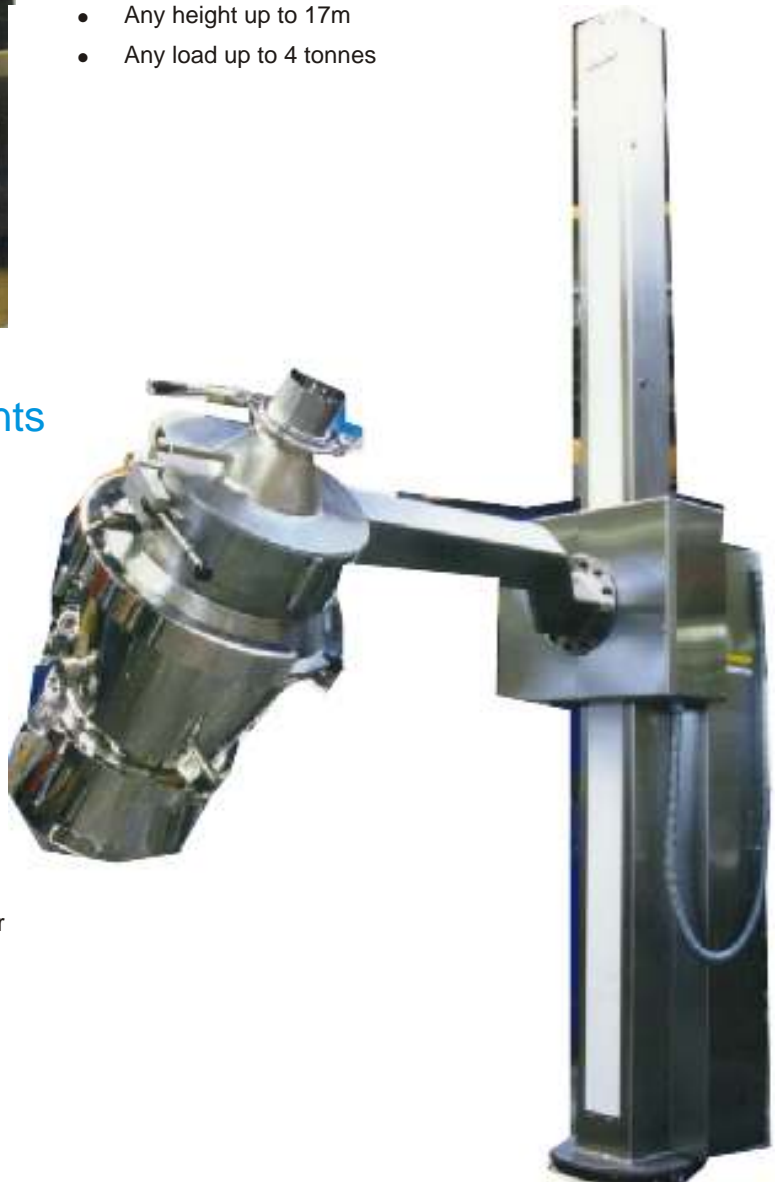

Drum Hoists & Processing

3 Drum Handling

There are many methods available for clamping drums. Pharmatech are able to advise you about the most suitable system for your application.



Powered Vertical Clamping and Transverse Inversion
Suitable for metal, plastic and fibre board drums

Drum Hoist with manual clamping and powered inversion.
Loading a mixer granulator with a drum hoist



Drum Hoist with powered clamping and powered parallel inversion.



Powered Horizontal Clamping and Parallel Inversion



Clamp Liners

Clamp Liners allow the effective diameter of the clamp to be reduced to allow a smaller diameter drum to be handled. Clamp Liners are easily fitted within seconds and without the need for tools.

IBC Hoists & Processing

4 IBC Handling & Processing

Pharmatech offer a range of IBC hoists. Usual applications are:

- Moving IBCs between floors
- Hold IBCs directly above processing equipment so that the contents can be discharged under gravity
- Hoist Blenders - see page 5

IBC hoists can be up to 17m high and lift up to 4 tonnes.

Special designs are available on request.



High Lift IBC Hoist

IBC Hoist Blender lifting a 1500 litre IBC



IBC Hoist & IBC being used to feed a compression machine

NB. Use Pharmatech Dust Cap Seals to achieve a dust tight seal between the IBC and the hopper

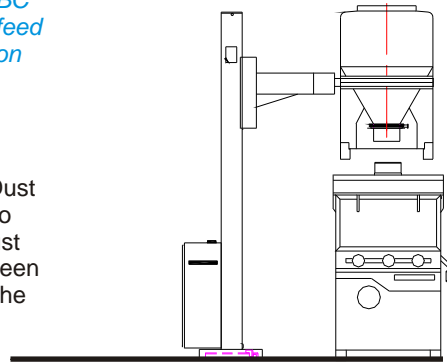

IBC Hoists -

The photograph shows a typical installation using the Pharamlift system. The hoists raise and position the IBCs for gravity discharge.



Hoist Blenders

5 Standard & Special Machines

Pharmatech Hoist Blenders are an efficient way to utilise space and are ideal when handling containers such as IBCs and Drums.

The hoist is used to lift the blending container sufficiently high so that it can be rotated without striking the floor then, if required, the hoist can lift the container so that it can be discharged directly into the next processing stage.

- Blend loads up to 4000kg
- Relay logic or PLC controlled machines
- Ex rated to any standard
- Free standing or through wall installations
- Slewing around vertical column axis



Hoist Blender with a 200 litre drum

NB. Drum is tilted to achieve an efficient, asymmetric blending action

C Frame Blender

'C' frame blenders have an elegant clamping system where the arms of the blender clamp onto a bar which is welded onto the side of the IBC.

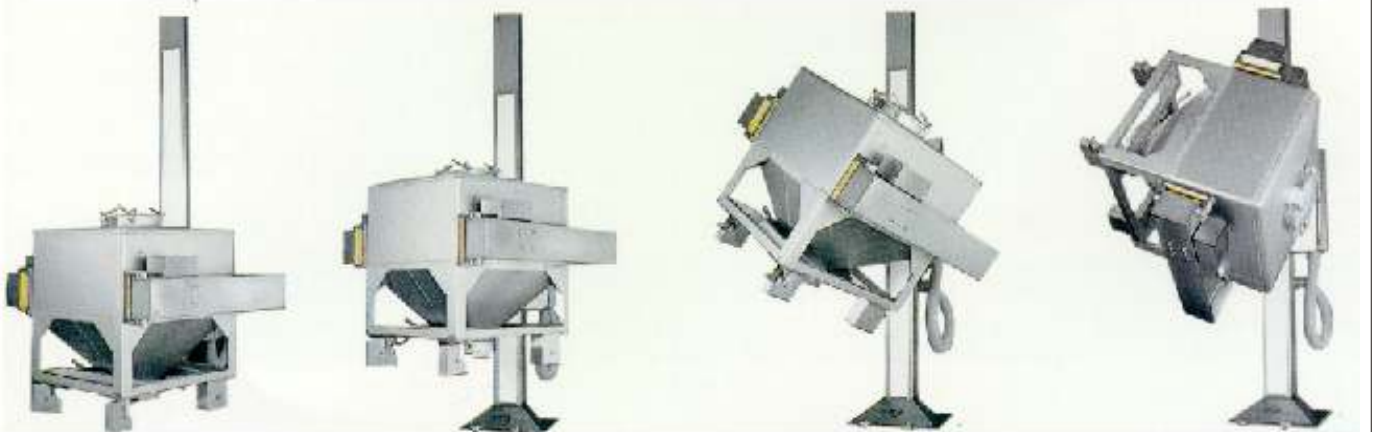

Clamp

Lift

Blend.....

Cage Blender

- Cage Blenders clamp the IBC at the top and bottom and are able to handle IBCs of up to 3000 litres.
- Pharmatech's special cage design allows IBCs of different sizes to be used within a single cage.
- Blender can pick up IBC from a pallet truck or work with AGVs



Cage Blender ready to receive an IBC

When the IBC is in position the lower section raises to clamp the IBC in place and to provide ground clearance for blending

Special Hoists

6

Special Machines

The lifting and rotating facilities offered by Pharmalift Hoists make them ideal for lifting and positioning other items of processing equipment and machinery eg. mills, vacuum transfer units etc.

Fluid Bed Drier Bowl Inverter

The hoist is fitted with a special cone which clamps to the FBD bowl. The hoist will then lift and invert the FBD bowl. A mill can be fitted to the outlet, if required. The contents can then be discharged into IBCs or directly into the hopper of the next item of processing equipment.

- Machines custom built to suit existing FBD Bowl
- Allows dust free processing of dried granules
- Production and laboratory scale machines



Mill Hoist with weighing system.

The product is discharged from the mill into an IBC (not shown)

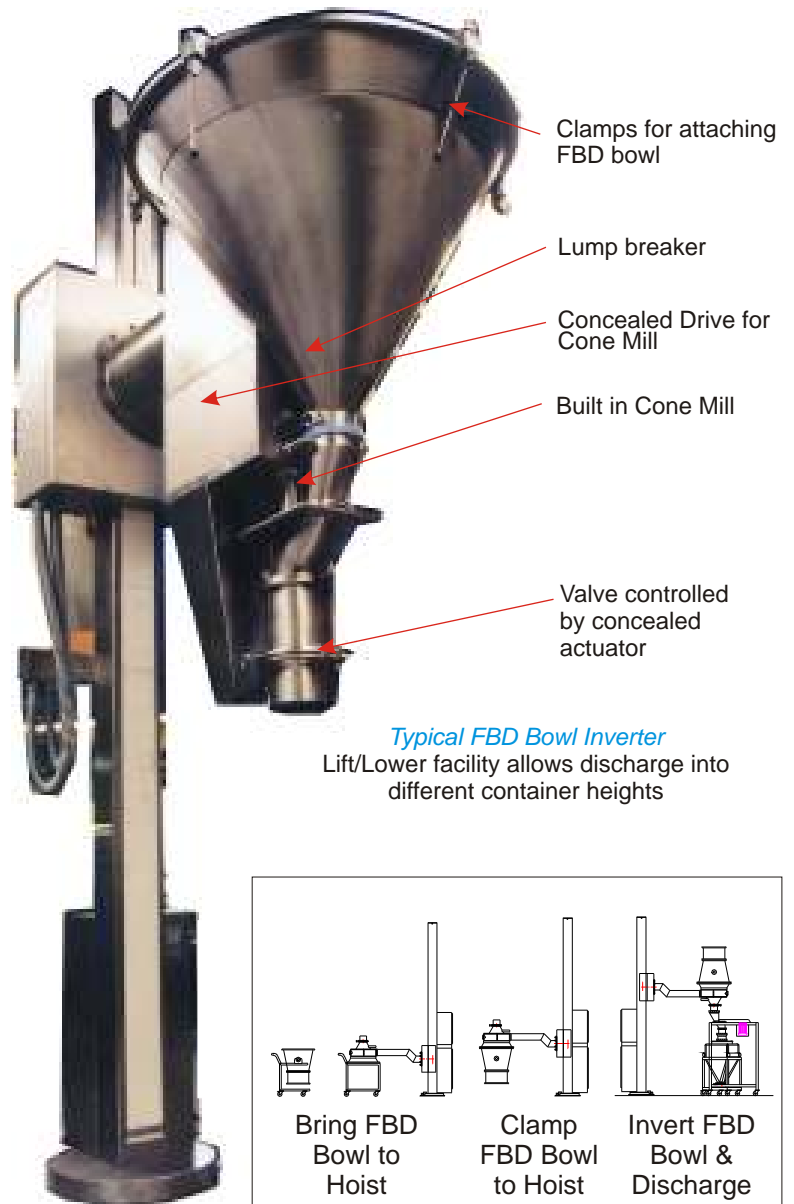

Mobile Hoists

Mobile Pharmatech Hoists are highly versatile and useful items of equipment. They are available in a range of sizes and with either manual or powered traction.

Clamping arrangements are designed to suit the application.

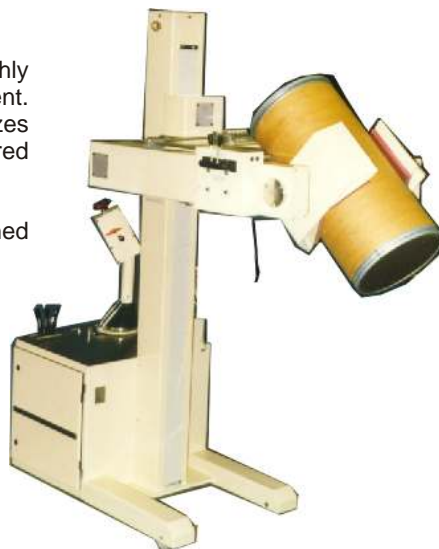

Special Hoists continued

7 Special Drum Hoist

Usually Pharmatech Hoists have a brush polished stainless steel finish. However in certain caustic environments additional protection is required. The hoist shown [right] has a special Epoxy covering, allows it to be sited in a caustic environment where unprotected stainless steel would be chemically eroded.

Discharging Problem Products?

The hoist shown to the right is fitted with a Flexicone discharge system. The Flexicone is a patented device that prevents bridges from forming and thereby promotes product discharge. The Flexicone has been proved to be highly effective, even with damp products.

The Flexicone is ideal for GMP applications because there are no moving parts within the product.

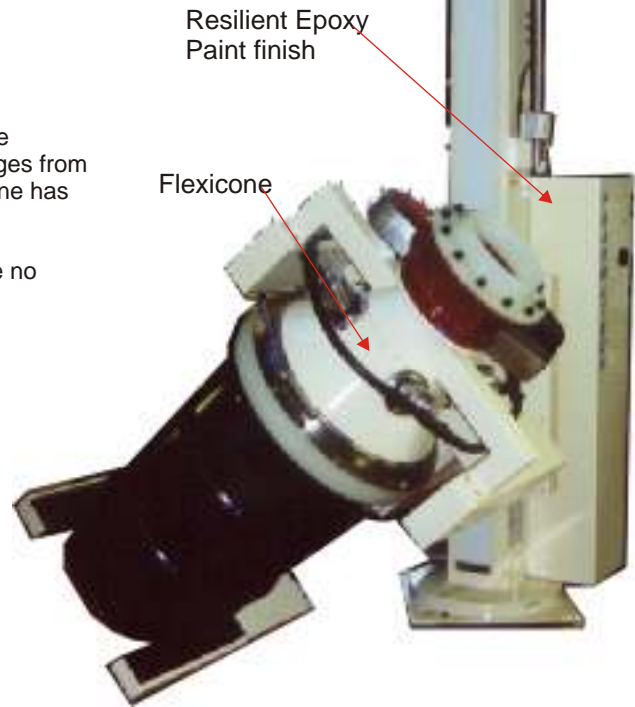
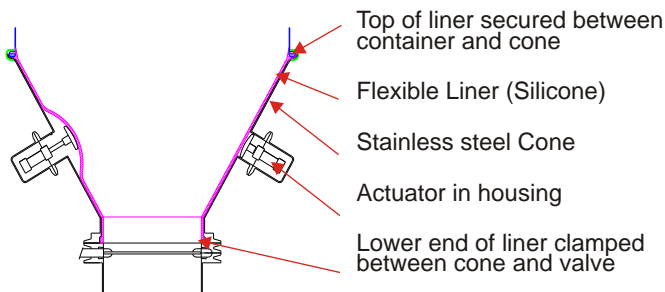

Process Automation

Pharmalift Hoists are ideal for installation at the heart of fully automated processing stations.

Two typical examples of automated stations are:



Left
Hoist picks up drum from the upper roller-conveyor. The drum is then inverted and the product discharged. The empty drum is placed on the lower roller-conveyor.



Right
The drums are picked up and inverted, they are then placed on a discharge rack for gravity discharge on an automated dispensing system

Brochure Request Service

For more detailed information photocopy this page, tick the brochures that you require and then fax the sheet back to us.

Name:

Job Title:

Company:.....

Tel:

Address:.....

Fax:.....

.....

E-mail:

.....

Tick Box to request brochure



Blenders



Hoists



Dust Free Transfer



Drum & Keg Tippers



**Processing
Grade Drums &
IBCs**



**Powder Handling
Aids**



**Sampling
Equipment**



Dispensing Ware

Local Distributor

© Terriva Ltd. 2009. Reproduction of this brochure in part or full is prohibited unless prior approval is given in writing

Pharmatech is a division of Terriva Ltd.



Pharmatech

2 Forge Mills Park, Station Road,
Coleshill, Warwickshire. B46 1JH. UK.

Tel: +44 (0)1675 467636 Fax: +44 (0)1675 467582
Email: info@pharmatech.co.uk www.pharmatech.co.uk