

BALL SECTOR VALVE of stainless steel

455 (459) series





Description

Högfors ball sector valve series 455 is specially designed for control applications of various media like liquids, pulps and steam.

Högfors 455 V port control valves provide excellent control characteristics which are intermediate between linear and equal percentage. Manufactured in stainless steel with a hard chromed ball sector and the standard metal seat in stellite, the valve design ensures self cleaning, providing reliable service on difficult applications such as solids in suspension or on crystallizing media which would damage a soft seat. For clean applications the Fig 455 can be fitted with a glass filled PTFE seat which gives a bubble tight shutoff. The 455 flanged valve is full bore if reduced bore is preferred use the Fig 465 wafer pattern valve. The valve has a preferred direction of installation which is shown by an arrow on the body and the stem sealing is provided by graphite packing which can be adjusted by tightening the gland.

The ball valve series 459 is a tank outlet valve, a variation of the valve 455 series which incorporates a short body section thereby reducing dead area above the seat. The single seat design eliminates the possibility of media becoming trapped in the valve body.

Nominal dimensions:	(455 valve) - DN 25 – 300, (459 valve) - DN25 – 200	
* Nominal pressure	PN16bar	
Ball seal alternatives	Stellite (KC)	PTFE (TC)
Tightness class ISO 5208, EN 12266-1	RATE D	RATE A
Working temperature of liquid media (version for steam also available)	+260°C -40°C	+200°C -40°C
* Connection	Between flanges: EN1092-1, Facing Type B. PN16, PN10, ANSI CLASS 150.	
Safety	Conform to the requirements of the Council Directive 97/23/EC on Pressure Equipment, marking: Class: gas, group 1.  0575  Explosion-proof design is available as per special order. Marking in accordance to ATEX Directive 94/9/EC: group II 2 GD, protection concept of non-electrical components: c T6.	

*) Flange drilling for others standards and pressures are also available as per special order.

Consult factory for details.

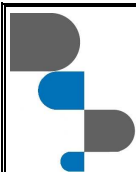

Exploded view

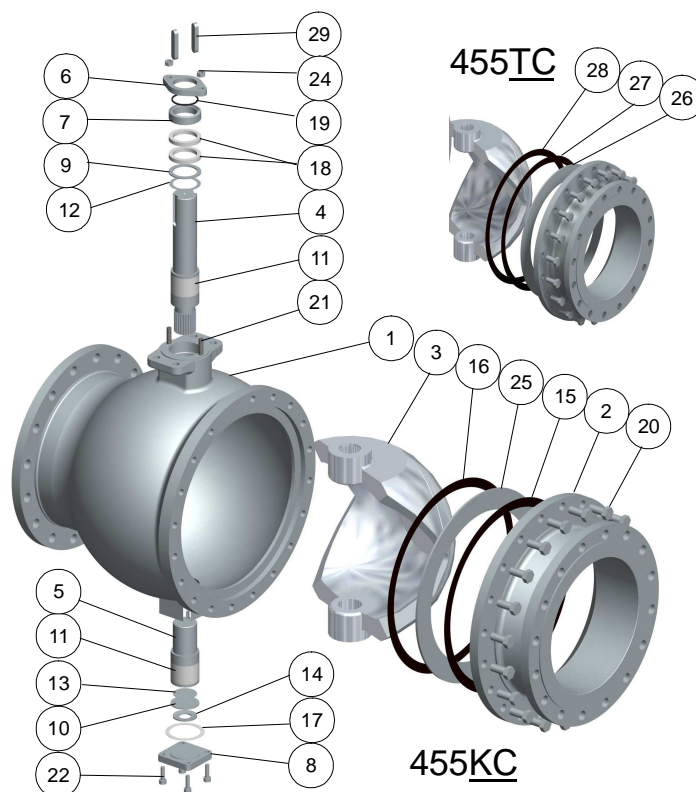

Parts list and standard materials

Part	Material	
1	Body	Stainless steel ASTM A351 CF8M
2	Body flange	Stainless steel ASTM A351 CF8M
3	V-ball	Stainless steel ASTM A351 CF8M
4	Stem	Stainless steel 1.4404
5	Subshaft	Stainless steel 1.4404
6	Gland	Stainless steel 1.4404
7	Spacer ring	Stainless steel 1.4404
8	Subshaft cover	Stainless steel 1.4404
9	Thrust bearing ring	Stainless steel 1.4404
10	Thrust bearing plate	Stainless steel 1.4404
11	Shaft bearing	PTFE on stainless steel net ("Pampus")
12	Upper thrust bearing	PTFE on stainless steel net ("Pampus")
13	Lower thrust bearing	PTFE on stainless steel net ("Pampus")
14	Cup spring	Stainless steel 1.4404
15, 16	Shim	Carbon Fibre SFS5811/ Graphite
17	Subshaft cover packing	Carbon Fibre SFS5811/ Graphite
18	Packing	Graphite
19	O-ring	EPDM
20	Bolt or stud and nut	Stainless steel ISO 3506 A4-80
21	Stud	Stainless steel ISO 3506 A4-80
22	Hexagonal socket screw	Stainless steel ISO 3506 A4-80
24	Nut	Stainless steel ISO 3506 A4-80
25	Seat	Stellite
26	Seat	PTFE
27	Support ring	Stainless steel 1.4404
28	Shim	Carbon Fibre SFS5811/ Graphite
29	Key	Carbon steel

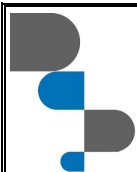

Dimensions. 455 series valve

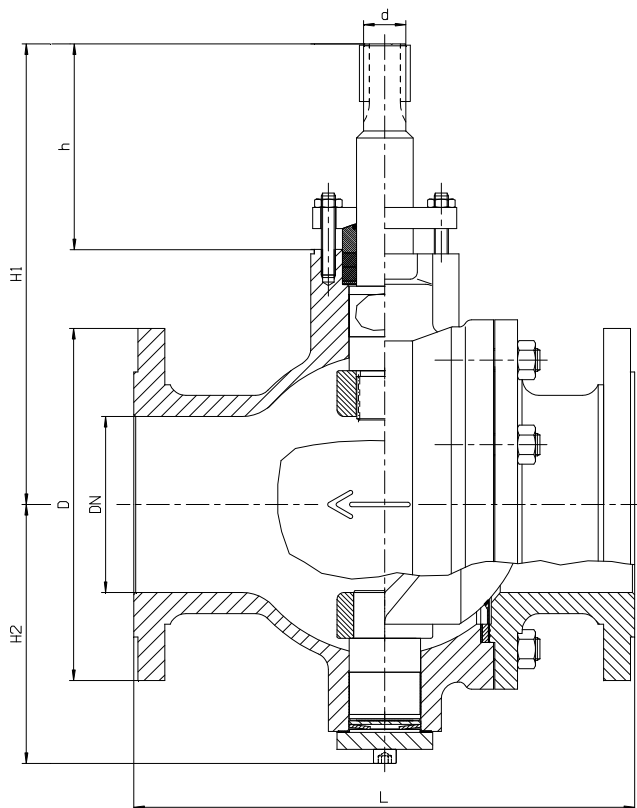

DN	L	H1	H2	h	d	D	Connection PN16			Weight kg
							Dr	hole Ø	pcs	
25	127	143	68	85	11	115	85	14	4	5.0
32	140	166	79	95	15	140	100	18	4	7.7
40	165	170	83	95	15	150	110	18	4	9.5
50	178	196	91	110	20	165	125	18	4	12
65	190	204	99	110	20	185	145	18	4	17
80	203	235	126	115	25	200	160	18	8	23
100	229	245	136	115	25	220	180	18	8	27
125	356	329	185	150	30	250	210	18	8	55
150	394	343	199	150	30	285	240	22	8	67
200	457	404	248	170	45	340	295	22	12	122
250	533	439	283	170	45	405	355	26	12	230
300	610	510	337	185	60	460	410	26	12	280

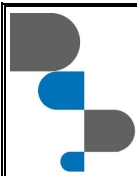

Dimensions. 459 series valve

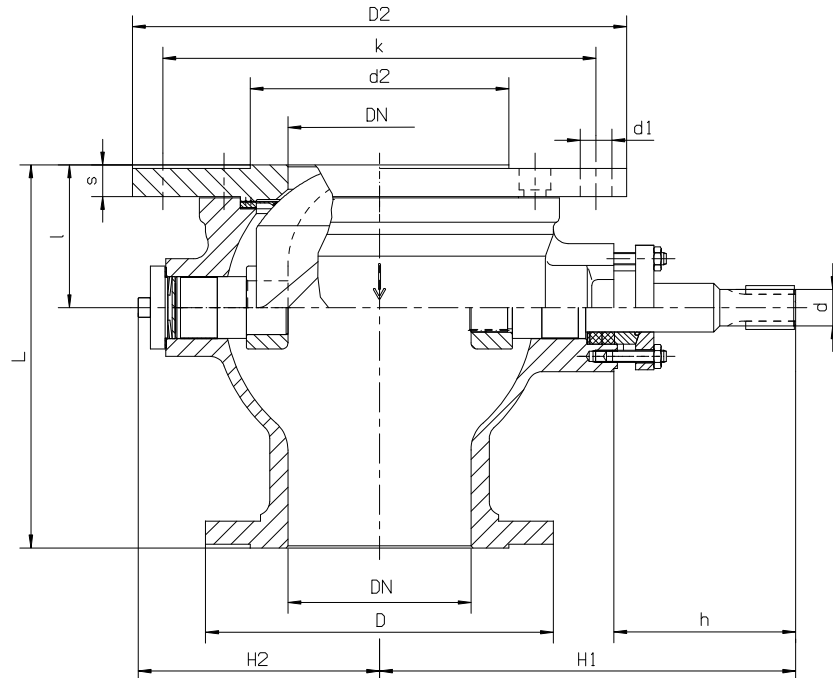

DN	L	I	H1	H2	h	Ød	ØD	Bottom flange						Weight kg
								ØD2	s	Ød2	Drilling PN16			
											Øk	Ødl	pcs	
25	89	39	143	68	85	11	115	165	18	60	125	18	4	4.7
40	124	49	170	83	95	15	150	200	20	88	160	18	8	9.6
50	132	54	196	91	110	20	165	220	20	98	180	18	8	10.7
65	142	63	204	99	110	20	185	250	22	116	210	18	8	14.4
100	180	83	245	136	115	25	220	285	22	158	240	22	8	24
125	281	103	329	185	150	30	250	340	26	188	295	22	12	50
150	314	117	343	199	150	30	285	405	26	212	355	26	12	59
200	382	155	404	248	170	45	340	520	30	268	470	26	16	140

Operation

Högfors valves can be equipped with an actuator to your specification.

- bare shaft,
- manual gear,
- electric actuator,
- pneumatic or hydraulic actuator.

Operation torque

DN	25	32	40	50	65	80	100	125	150	200	250	300
Torque*, Nm (KC and TC)	20	28	39	52	70	100	150	240	340	520	600	1'000

*) for steam use the next size up.

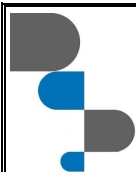

Handlever

Sizes DN 25-150 can be operated with handlever.

The opening and closing of valves is stepless.

The valve is open when the handlever is in line with pipe.

DN	L	I	H	h
25	127	185	180	68
32	140	300	200	79
40	165	300	205	83
50	178	300	225	91
65	190	300	235	99
80	203	420	270	126
100	229	420	280	136
125	356	420	362	185
150	394	420	375	199

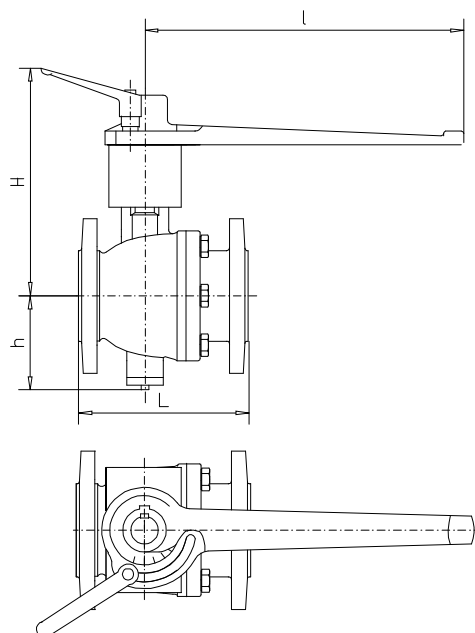

Manual gear

Opening and closing of the valves from the handwheel.

The position of the ball can be seen on a position indicator on top of the gear.

DN	Pro-Gear model	a	b	c	d	L	D	h
25	Q400	198	52.5	252	200	127	115	68
32	Q400	198	52.5	264	200	140	140	79
40	Q400	198	52.5	268	200	165	150	83
50	Q400	198	52.5	289	200	178	165	91
65	Q400	198	52.5	297	200	190	185	99
80	Q800	293	68.75	381	300	203	200	126
100	Q800	293	68.75	391	300	229	220	136
125	Q800	293	68.75	470	300	356	250	185
150	Q800	293	68.75	484	300	394	285	199
200	Q4000	406	137.5	639	500	457	340	248
250	Q4000	406	137.5	674	500	533	405	283
300	Q4000	406	137.5	730	500	610	460	337

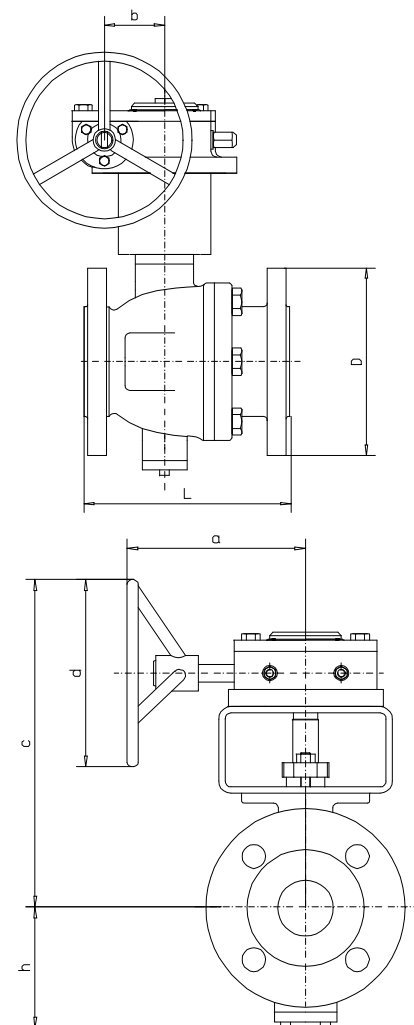

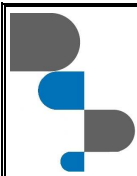

Pressure / Temperature Rating.

The max pressure difference depends on the working temperature of liquid media.

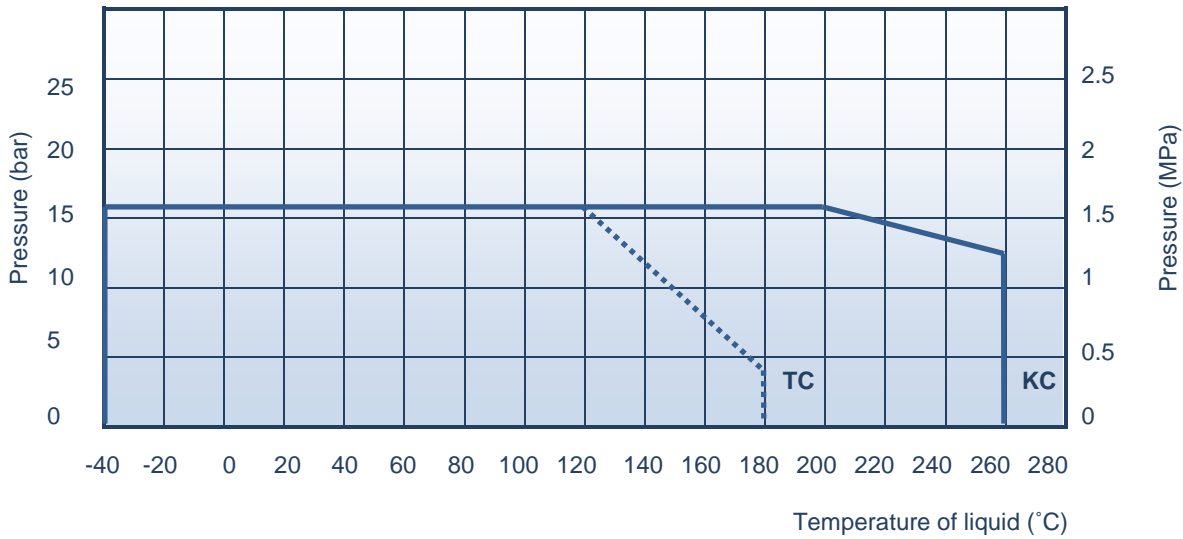

Product codes

Seat	Ball sector valve		Tank outlet valve	
	PTFE	Stellite	PTFE	Stellite
handlever up to DN150	455TC__.	455KC__.	459TC__.	459KC__.
bare shaft	455TC__Z	455KC__Z	459TC__Z	459KC__Z
manual gear	455TC__M	455KC__M	459TC__M	459TC__M
Steam version on special order	–	45501KC__	–	–

How to order

		4	55	01	K	C	200	M
Body material:	4 – Stainless steel							
Valve type:	55 – ball sector valve with flanges 59 – ball sector valve for tank outlet							
Special options:	__ – standard, 01 - For steam							
Ball seal	(K) - Stellite, (T) - PTFE							
Ball surface treatment	C – hard chrome							
Size DN								
Operation:	(_) - handlever, (Z) - bare shaft, (M) - manual gear							

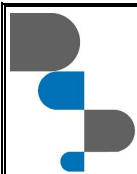

Flow curves

Indicating typical Kv value.

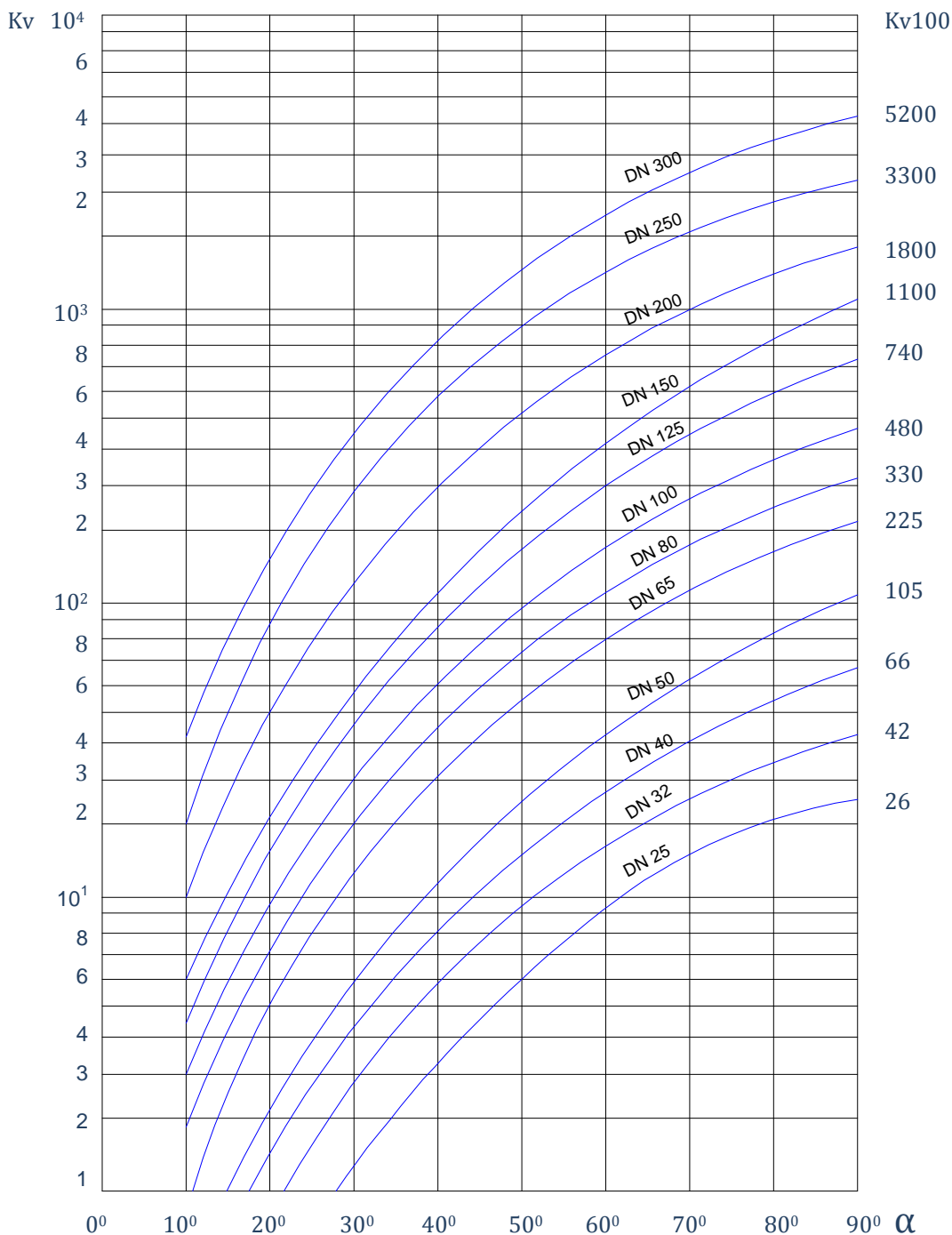

WATER:

Volume flow: $Q = K_V \sqrt{\frac{\Delta p}{\rho}}$

Flow velocity: $V = 354 \frac{Q}{DN^2}$

K_V = KVvalue – Capacity factor

DN = nominal valve size (mm)

α – disc opening angle

Δp = pressure difference, bar

ρ – density of liquid kg/dm³

V – flow velocity m/s

Q – volume flow m³/h