

# PR6 OPEN PLATFORM LIFT

## Technical specification

Maximum load	500 kg
Translation speed	0.08m/s
Max Travel length	3m
Drive system	Hydraulic
Electrical Connection	Single Phase 220V, 50Hz
Electric box	400x500x200 max distance from the rail 5 m.
Car Control Unit	"Hold to run" buttons
Landing Control Units	On gate control or on remote posts as option
Colour Finish	RAL 9007 as standard Other colours available

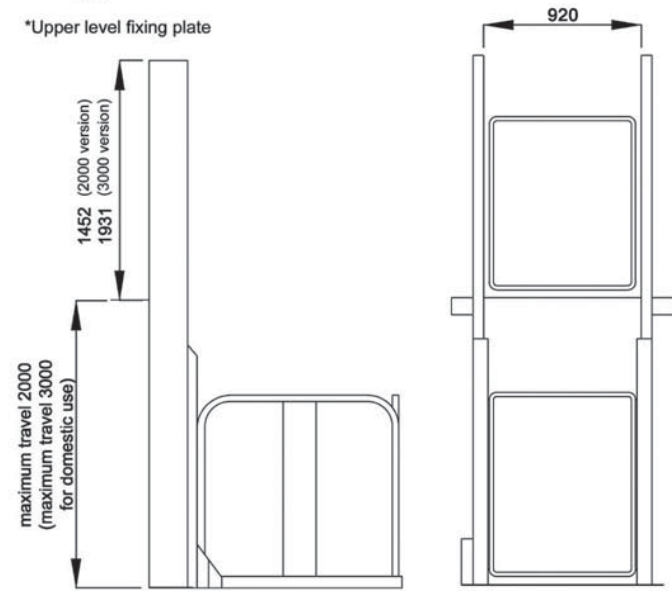
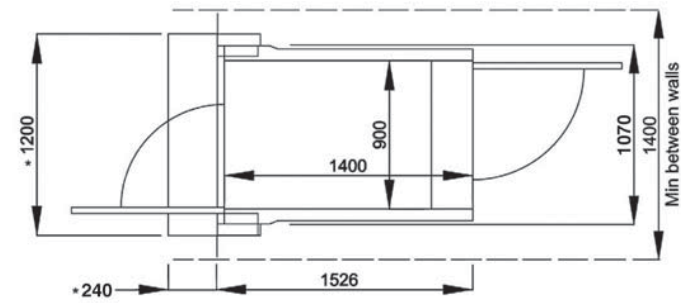

ALTA LIFTS LIMITED  
 UNIT 1 SIDINGS BUSINESS PARK  
 FREIGHTLINER ROAD  
 HULL HU3 4XA  
 TEL: 01482 480710  
 mail@altalifts.co.uk