

# PR7 range - Short Rise Vertical Platform Lifts

A range of platform lifts ideal for rising up to 1 metre

## Technical Information

Built in Compliance with BS 6440:1999

Safe working load = 300Kg

Maximum threshold height = 1000mm

Lift speed = 20mm/sec

Ramp gradient = 1:6

Power supply = 230V ac 50Hz single phase & earth

Power Consumption = 230 Watts

Lift operating voltage = 24V dc

Battery Powered raise and lowering

Manual emergency lowering

Hydraulic drive

Total lift unladen weight = 200Kg

Suitable for internal and external use

## Note:

A turning circle of diameter 1500mm is recommended at the entrance and exit points of the lift for access.

A minimum of 2000mm is required above the threshold height.

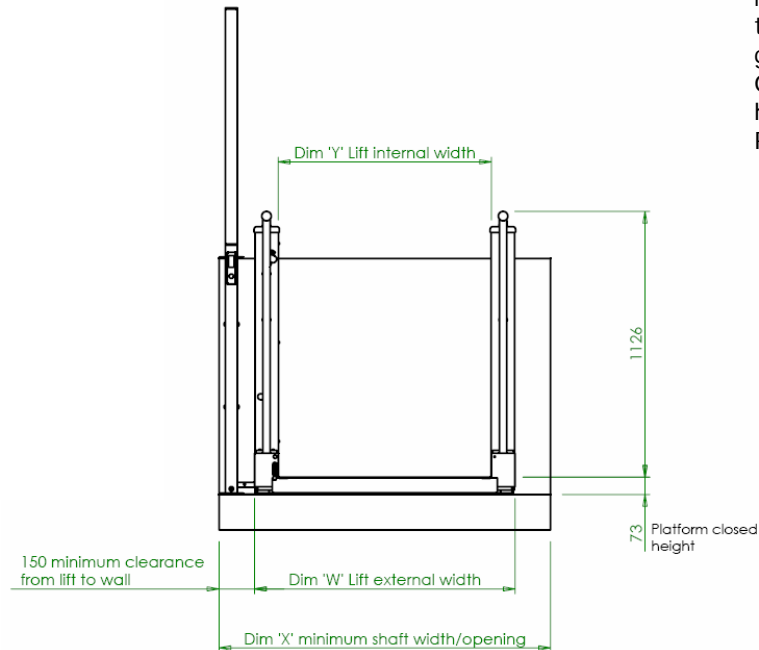
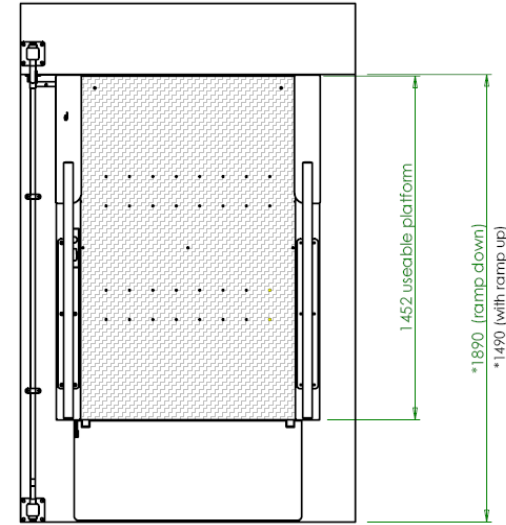
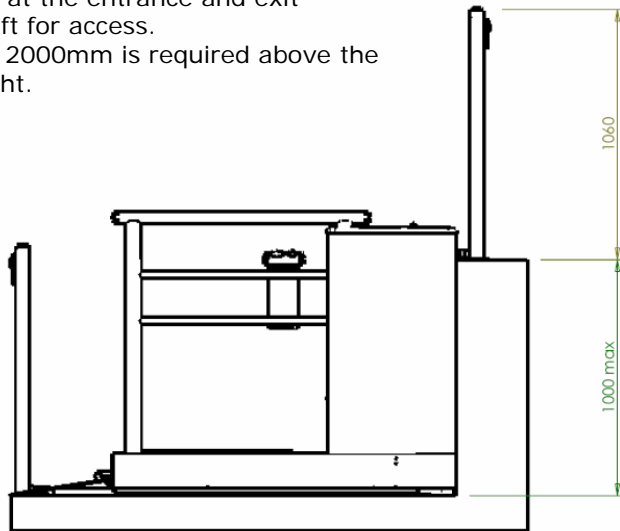

ALTA LIFTS LIMITED

TEL: 01482 480710

mail@altalifts.co.uk

## UPPER LEVEL GATE OPTION DETAILS

\*Note: Add 55mm to the length dimension when a gate option is fitted.

The standard gate opening is 900mm for both the LR800 and LR900 lifts.

Must have minimum of 250mm threshold height when fitting a gate.

Gate must be fitted on threshold heights above 380mm (Building Regs Part K)

	LR800	LR900
Dimension W	1004	1104
Dimension X	1304	1404
Dimension Y	800	900