

---

## HYDRAULIC EXTERNAL VIBRATORS

---

### MODEL VHE 5

- Rotary Vibrator
- High Amplitude
- Variable Frequency
- Lightweight

On request can be supplied with ATEX certification  
To ATEX 95 94/9/EC  II 2 G & D Zone 1, 2 & 21, 22

2 CHAPEL ROAD, PORTSLADE, BRIGHTON, BN41 1PF ENGLAND  
Tel. +44(0) 1273 430977 Fax. +44 (0) 1273 430978  
Web. [www.vibtec.com](http://www.vibtec.com) E-mail. [sales@vibtec.com](mailto:sales@vibtec.com)

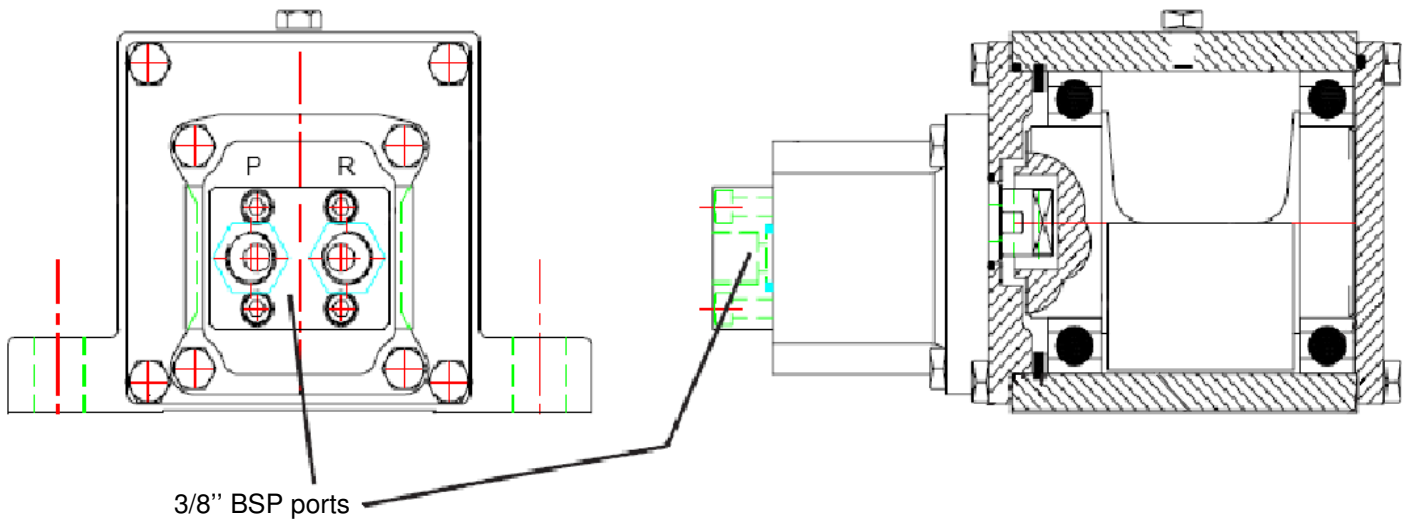
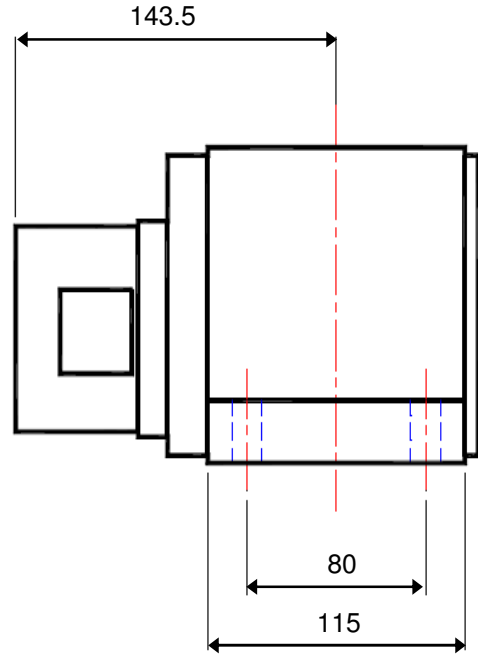
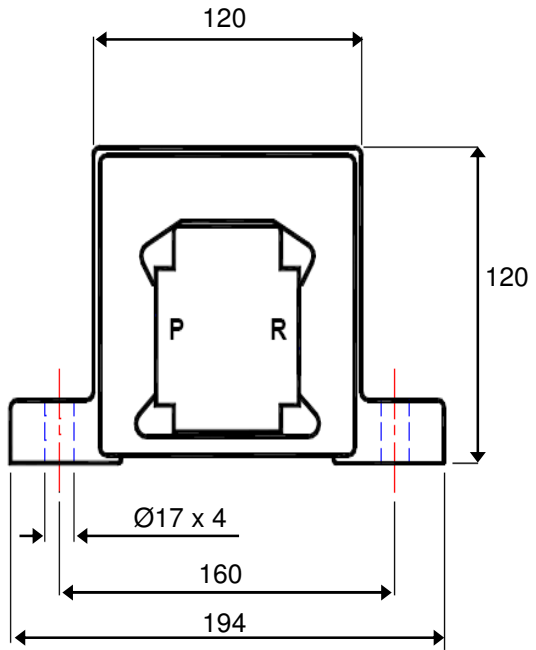

**PERFORMANCE DATA**

TYPE	Weight (Kgs)	Working Moment (Cm/kg)	Continuous Operation			Intermittent Operation		
			RPM	Force (N)	L/Min	RPM	Force (N)	L/Min
VHE 5/500	6.35	2.05	6000	4065	12	7000	5545	14
VHE 5/900	7.5	6.6	4000	5865	8	5000	9090	10

Oil Pressure : 40 - 100 Bar

1 RPM = 2cc Oil Volume

Max. permitted back pressure: 2 Bar