

VTP 25 PNEUMATIC LINEAR VIBRATORS OPERATING MANUAL

Vibration Solutions

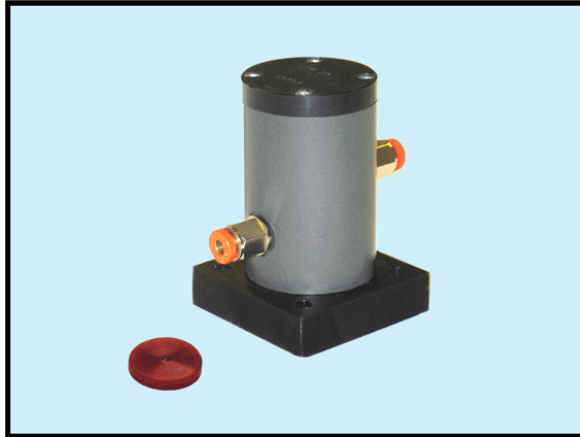

Technical Characteristics

Model	Nominal Frequency v.p.m.			Force N			Air Consumption l/min		
	2 bar	4 bar	6 bar	2 bar	4 bar	6 bar	2 bar	4 bar	6 bar
VTP 25 Cushioned	2600	3200	3800	66	164	260	18	56	122
VTP 25 Impacting	4780	6900	8380	130	310	500	25	72	160

IMPORTANT NOTICE

Vibrators and vibrating equipment can be dangerous if not used correctly.

1. **DO NOT** hold or touch when running.
2. **DO NOT** stand or sit on vibratory equipment when running.
3. **USE ONLY** for the purpose intended.
4. **USE ONLY** when vibrators are securely mounted.
5. **USE ONLY** when pneumatic hoses and fittings are securely tightened.
6. **ALWAYS** wear ear protectors.



OPERATING AND MAINTENANCE INSTRUCTIONS

Installation

1. Pneumatic vibrators should always be installed by a competent person and in accordance with the Health and Safety at Work. Act 1974 when used in the UK.
2. An air on/off valve must be fitted to the system, which is easy to reach and easy to operate for isolation of the air supply by the operator.
3. The vibrator is designed to be bolted securely to equipment and to produce vibrations in the equipment and apparatus.



ATTENTION Do not attempt to run unattached.

4. The vibrator should always be used securely fixed to a mounting plate of apparatus. It can be installed on hoppers, chutes, concrete block making machines or shuttering using 4 off 10mm diameter high tensile bolts (quality 8.8 - DIN 931-933) at 95.25mm (3.375") P.C.D.
5. The surface of the mounting plate to which the vibrator is attached must be flat.
6. Due to the impacts delivered by the vibrator, depending upon the type and nature of the apparatus to which it is fixed, a high noise level may result, hence personnel in close proximity must use ear protecting equipment.
7. Ensure that the air supply hose is oil resistant and has an abrasion resistant exterior surface, is suitable for the working pressure and that hose end fittings and connections are of the correct type and size.
8. Long hoses should be avoided as it would greatly effect performance.

Pneumatic supply

For maximum operating efficiency, the following air supply specifications should be maintained:

- Maximum air pressure 7 bar (100 psig);
- Recommended pressure 6 bar (90 psig) at vibrator inlet with tool operating;
- Air filtration - 50 micron;
- Lubricated air supply;
- Hose size 8mm (5/16") ID x 4.5m (15ft) maximum length;
- Thread on tool 1/8" BSP
- Maximum air consumption 4.2 l/s (9 cfm).

Important: Do not let the working pressure exceed 7 bar (100 psig). If the vibrator is to be connected to a supply where this possibility could occur, a "pressure reducing valve" must be fitted to ensure the maximum permitted working pressure cannot be exceeded. The installation of a combined Filter/ Regulator/ Lubricator unit (FRL) is strongly recommended. That will not only remove particles of dirt, abrasive matter and moisture from the air supply, but will control the air supply pressure and automatically feed oil to the vibrator during its operation. When the vibrator is connected according to the above instruction, the on/off valve is used to control the compressed air supplied to the vibrator. It is therefore important that the recommended air supply conditions are maintained otherwise maximum performance will not be achieved.

Contact Vibratechniques Ltd. for details of suitable Filter/ Regulator/ Lubricator units (FRL), hoses, fittings and quick release couplings.

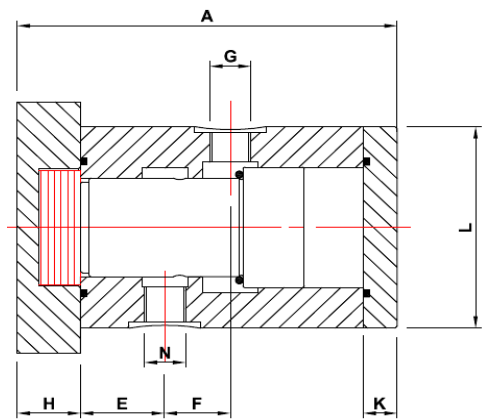
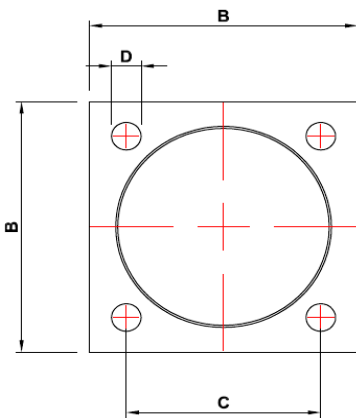

Dimensions												
MODEL	A mm	B mm	C mm	ØD mm	E mm	F mm	G BSP	H mm	K mm	ØL mm	N BSP	WT kgs
VTP 25	90	63.5	46	6.5	35	15.5	1/8"	15	8	51	1/8"	0.635

Safety precautions

1. Always use ear protectors when the noise level at the operators position exceeds 85 dB(A).
2. Vibrators should always be used securely bolted to the apparatus. They must not be used in a hand held condition.
3. The apparatus onto which a vibrator is attached, must not be subject to fatigue failure as a result of the induced vibration. Mountings should be suitably rigid.
4. Fixing bolts and hose connections must be securely tightened and checked regularly.
5. Do not use damaged, frayed or deteriorated hoses and fittings. Always protect hoses away from heat sources or sunlight and inspect before use. A hose failure will whip and can cause injury; turn air off immediately.
6. If the vibrator appears to malfunction, remove it from use immediately and arrange for service/ repair. At any sign of malfunction or unusual behaviour, the vibrator should be taken out of service for examination and repair.
7. Do not modify the vibrator unless first agreed with the manufacturer in writing and do not remove or allow to become obscured any labels or inscriptions, particularly statutory information.
8. Care should be taken to ensure the vibrator's exhaust does not cause a hazard.
9. Should any lubricant contaminate the eyes or be accidentally ingested, seek medical advise immediately.
10. When handling lubricants regularly, wear suitable gloves of impervious material. Clothing contaminated with lubricant should be changed.



Routine lubrication

Generally no maintenance is required other than keeping the vibrator clean and suitably lubricated.

Lack of or an excessive amount of lubrication will affect the performance and life of the vibrator. Use only recommended lubricant at time interval set out below. Every 8 hours of tool operation refill lubricator reservoir of recommended FRL unit with Shell Tellus R10 or equivalent . Set lubricator to 3-4 drops per minute.

Service & repair

This must only be carried out by an authorised repairer or distributor.

VIBTEC
VIBRATECHNIQUES LTD

Vibration Solutions

2 CHAPEL ROAD, PORTSLADE, BRIGHTON, BN41 1PF ENGLAND
Tel. +44(0) 1273 430977 Fax. +44 (0) 1273 430978

Web. www.vibtec.com E-mail. sales@vibtec.com