

VTC VACUUM CLAMPS OPERATING MANUAL

Vibration Solutions

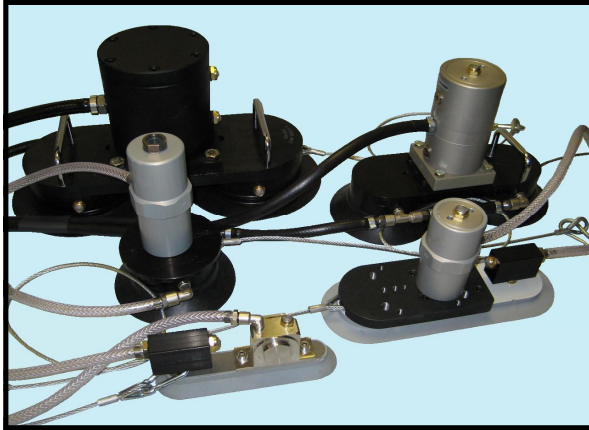

COMPATIBILITY

| MODEL | COMPATIBLE UNITS | Min Diameter mm | Air Consump. CFM (litr) | Weight (Kgs) |
|---------|---|-----------------|-------------------------|--------------|
| VTC 10S | DAR2, K8-10, GT4-10, FP12-18, R50, T50, VTL155-165, FAL 18 | 110 | 2.79 (79) | 1.5 |
| VTC 12S | DAR2 / DAR4, K8-25, FP25-35, R50-80, GT08-25, T50-80, V150 | 350 | 2.79 (79) | 3.0 |
| VTC 15S | DAR2-3, K8-16, GT4-16, FP12-18, R50-65, T50-65, VTL155-255, FAL18-25 | 760 | 2.79 (79) | 2.5 |
| VTC 15D | DAR4, GT20-30, K20-36, R80, T80, FP25-FP35, FAL25-35, FP50M, VFP75/01, VFP50/01 | 760 | 5.58 (158) | 4.5 |
| VTC 20S | K20-25, GT20-25, FP50M-60M, FAL35, R80, T80, VFP54/02 | 860 | 2.79 (79) | 4.0 |
| VTC 20D | DAR5, GT30-36, R100, T100HP, FP60M, FP95M | 860 | 5.58 (158) | 8.5 |
| VTC 20T | VFP50/10 | 4600 | 8.37 (237) | 18.0 |

IMPORTANT NOTICE

Vibrators and vibrating equipment can be dangerous if not used correctly.

- DO NOT** hold or touch when running.
- DO NOT** stand or sit on vibratory equipment when running.
- USE ONLY** for the purpose intended.
- USE ONLY** when vibrators are securely mounted.
- USE ONLY** when pneumatic hoses and fittings are securely tightened.
- ALWAYS** wear ear protectors.



OPERATING AND MAINTENANCE INSTRUCTIONS

The VTC range operate on compressed air from 3.5 up to 6.0 bar max. Lubricated air does not need to be used when vibrator requires no lubrication i.e. GT, FPLF.

The working temperature should be in range -10°C to $+70^{\circ}\text{C}$.

Installation

The VIBTEC Vacuum Clamps come with fitted hose sets and pre-drilled for all the appropriate vibrators stated in this leaflet. Vacuum caps hold best on flat surfaces, but can be applied to almost any radiused surfaces indicated in the table on the front page of this leaflet. Surfaces must be fairly smooth (no dents), dry and clean.

1. Hold unit against surface and switch on vacuum control valve.
2. Connect safety cable vertically above the unit and adjust, then switch on the vibrator.
3. If the supplied air fails releasing the vacuum clamp, it should not be able to swing dangerously to cause damage or injury.
4. When not in use, wipe/ clean vacuum cups and protect from damage.

Maintenance

Generally little maintenance is required if good quality filtered air is used.

1. To remove the vacuum generator/ venturi for cleaning, unscrew air fitting and silencer, then lightly tap to remove spacer and generator/ venturi. If these do not readily drop out, push out with wooden stick.
2. Make sure the silencer is cleaned and re-fitted in the same port.

ATTENTION

Always ensure compressed air is off during installation or maintenance.

Always ensure only filtered air is used and the filter cleaned regularly.

Always use suitable bolts, locking washers or Loctite for mounting vibrators.

Always maintain a regular check on the tightness of the fixing bolts and hose connections.

Always ensure vacuum exhausts to each cup are regularly inspected and cleaned.

Always ensure lubrication (when required) is adequate. Use lubricator accordingly to vibratory unit fitted.

Always ensure safety cables are fitted and adjusted on the VTC range.

VTC 10/12S

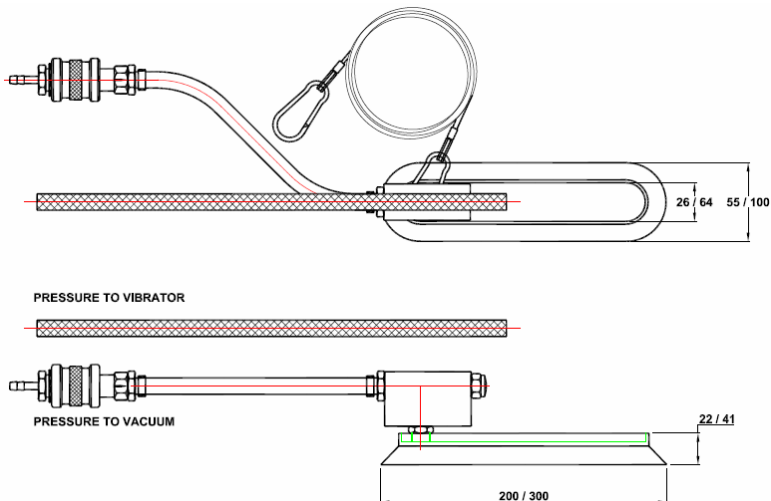

VTC 15/20S

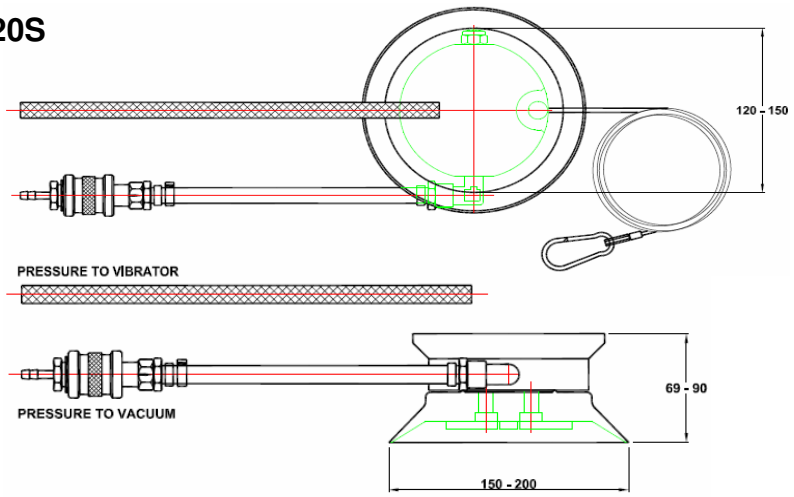

VTC 15/20D

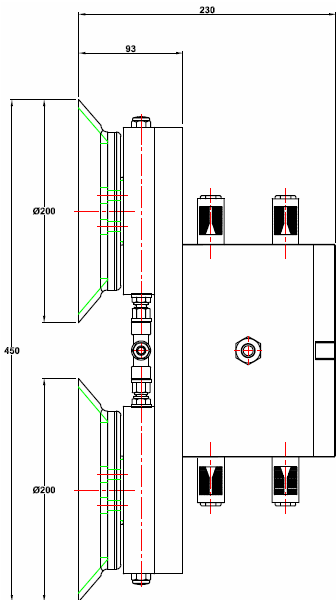
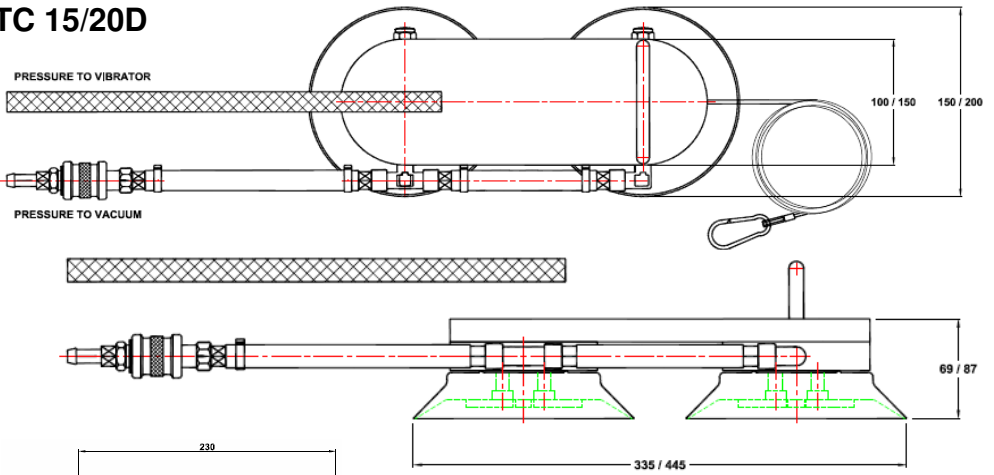

VTC 20T

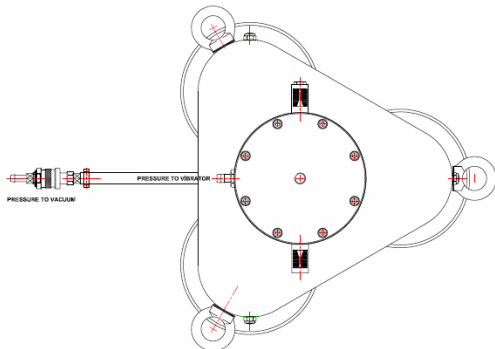

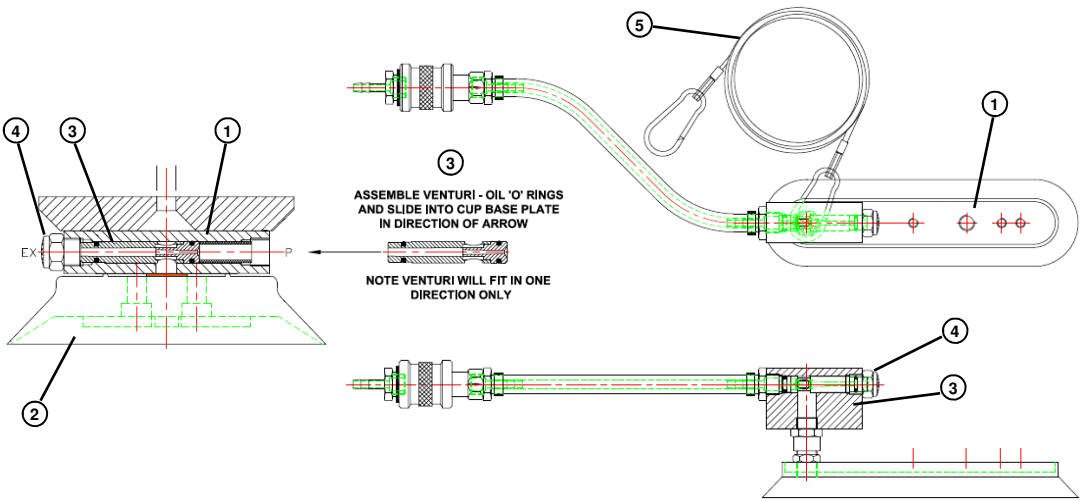

Spare Parts

| Ref. No. | Qty. | Description | Part Number | | | | | | |
|----------|------|---------------------|-------------|---------|---------|---------|---------|---------|---------|
| | | | VTC 10S | VTC 12S | VTC 15S | VTC 15D | VTC 20S | VTC 20D | VTC 20T |
| 1 | 1-3 | Base Plate | 54015 | 54058 | 54049 | 54049 | 54050 | 54050 | 54050 |
| 2 | 1-3 | Vacuum Cup | N/A | N/A | 46362 | 46362 | 46363 | 46363 | 46363 |
| 3 | 1 | Vacuum Generator | 54055 | 54055 | N/A | N/A | N/A | N/A | N/A |
| | 1-3 | Venturi Complete | N/A | N/A | 54052 | 54052 | 54052 | 54052 | 54052 |
| 4 | 1-3 | Steel Wool Silencer | 54054 | 54054 | 46076 | 46076 | 46076 | 46076 | 46076 |
| 5 | 1 | Shackle Assembly* | 54051 | 54051 | 54051 | 54051 | 54051 | 54051 | 54051 |

* VTC 10S has an extra 6mm carbine hook (part no. 45314).

VIBTEC
VIBRATECHNIQUES LTD

Vibration Solutions

2 CHAPEL ROAD, PORTSLADE, BRIGHTON, BN41 1PF ENGLAND
 Tel. +44(0) 1273 430977 Fax. +44 (0) 1273 430978

Web. www.vibtec.com E-mail. sales@vibtec.com