

## VAQ PNEUMATIC VIBRATORS OPERATING MANUAL

*Vibration Solutions*



### Technical Characteristics

Model	C/F N	Working Moment cm kg	Frequency v.p.m.	Air Consumption l/min	Weight Kgs	Weld-on Bracket	Noise level dBA
VAQ1000	11000	0.75	16500	1100	7.2	QR2	>102
VAQ1400	14250	1.02	16000	1200	7.3	QR2	>102
VAQ2500	25000	3.5	9000	1600	15	QR4	>102
VAQ2700	27000	1.95	16000	1600	14	QR4	>102
VAQ4000	40000	2.96	15200	1800	14.5	QR4	>102
VAQ4000S	40000	5.51	10200	1800	18	QR4	> 90
VAQ4500	45000	9.5	8500	1800	17.6	QR4	>102
VAQ6000	60000	5.4	14500	1800	16.3	QR4	>102

Performance data established in free air with a supply pressure of 6 Bar (87 p.s.i.)

### **IMPORTANT NOTICE**

**Vibrators and vibrating equipment can be dangerous if not used correctly.**

1. **DO NOT** hold or touch when running.
2. **DO NOT** stand or sit on vibratory equipment when running.
3. **USE ONLY** for the purpose intended.
4. **USE ONLY** when vibrators are securely mounted.
5. **USE ONLY** when pneumatic hoses and fittings are securely tightened.
6. **ALWAYS** wear ear protectors.

# Models VAQ 2500, 4500, 4000 & 6000

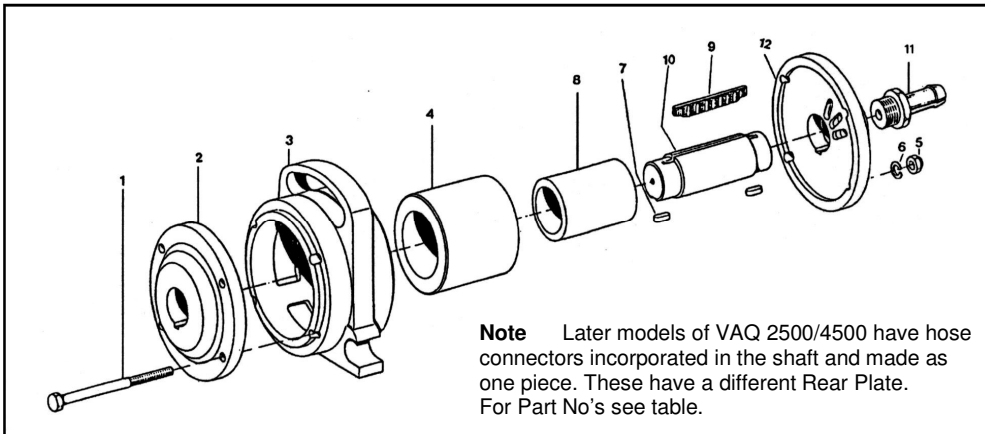

## Spare Parts

Ref. No.	Qty.	Description	Part No.				
			VAQ2500	VAQ4000	VAQ4000S	VAQ4500	VAQ6000
1	4	Bolt	3056	3056	3056	3056	3056
2	1	Front Plate	182006	182004	182008	182006	182004
3	1	Body	181004	181004	181004	181004	181004
4	1	Outer Rotor	187008	187004	187010	187006	187002
5	4	Nut	380	380	380	380	380
6	4	Spring Washer	936	936	936	936	936
7	2	Key	18054	2705	2705	18054	2705
8	1	Inner Rotor	184004	184002	N/A	184004	181002
9	1	Vane	2967	1599	187011	2967	1599
10	1	Shaft	841015	841006	185006	841015	841006
11	-	Hose Connector	N/A	141050	18008	N/A	141050
12	1	Rear Plate	841014	841005	183008	841014	841005
13	1	Silencer	N/A	N/A	187102	N/A	N/A



## Installation & General Maintenance

1. Vibrators are delivered without lubrication. Ensure to add oil before starting vibrator.
2. Before connecting the vibrator, ensure the is clean from any dirt or water.
3. Once a day or every two hours of continuous use, introduce 4 cc of 20/30 S.A.E. non-detergent oil into the vibrator airline.
4. Ensure vibrator cradle (QR Bracket) is fully welded to the equipment and that the Swing Bolt is locked in position and nut tightened securely. Check this regularly.

## Dismantling Instructions

Unscrew hose connector (11) and nuts (5), remove spring washers (6) and withdraw bolts (1). Place the vibrator body (3) on a vice locating the raised centre sections with front plate (2) on top. Using a soft drift, drive shaft (10) out of front plate (2). The shaft (10) will come out with the rear plate (12) still attached. The front plate (2) remains mounted in the vibrator body (3). Care must be taken not to drop and lose the keys (7) which may fall out of the shaft (10). Remove outer rotor (4) and inner rotor (8) from the assembly. Clean all parts with paraffin and dry carefully. Check the length of the rotors: Inner (12) 100mm - outer (4) 99.5mm when new. Maximum wear of the rotors must not exceed 0.2mm as speed and power is greatly reduced.

## Re-assembly Instructions

When fitting a new vane (9) ensure that the grooves are facing away from exhaust holes in the end plate, and that it fits freely but snug in the groove of the shaft (10). If necessary, carefully sand down the thickness with fine emery paper. The top of the vane must be flush or slightly under the lip of the groove in the shaft. Lightly oil all parts. Place the body (3), with front plate (2) attached, on a bench with front plate downwards. Locate inner rotor (8) and outer rotor (4) centrally in body (3). After re-fitting vane (9) in the groove of the shaft (10), fit keys (7) and insert shaft (10) with rear plate (12) attached through the rotors and locate on the front plate (2). Check alignment of key (7) in front plate (5). Fit hose connector.

## ATTENTION

- Always ensure compressed air is off during installation or maintenance.**
- Always ensure only filtered air is used and the filter is cleaned regularly.**
- Always check the weld of cradles for fatigue cracks regularly.**
- Always check swing bolt is securely tightened regularly.**
- Always check tightness of hose connections regularly.**



**VAQ 2500, 4500, 4000 & 6000 are fitted to QR4 weld - on bracket**

**Note** (VAQ4000S is a special version fitted with a silencer—see below)

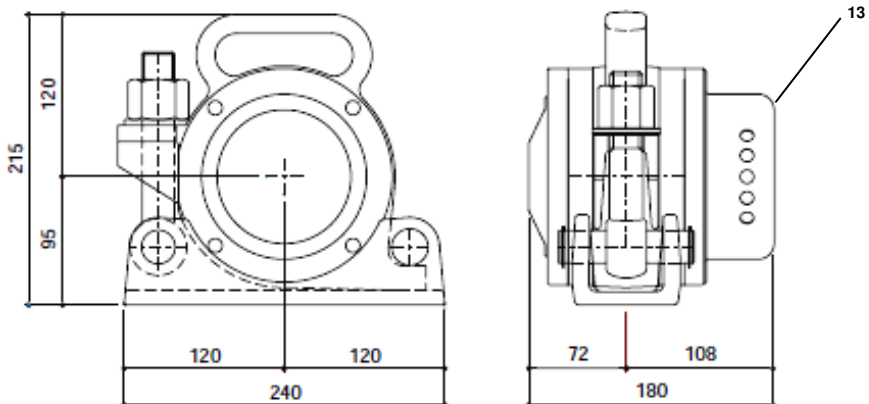

## Models VAQ 1000 & 1400

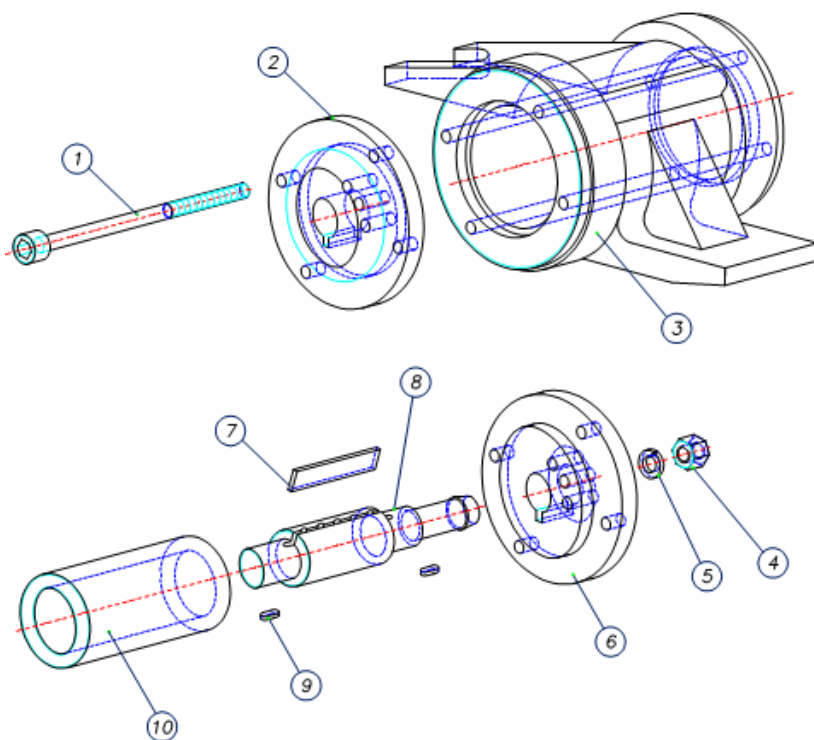

### Spare Parts

Ref.	Qty	Part Number	Description
1	4	46660	Bolt
2	1	46661	Front Plate
3	1	46662	Body
4	4	46663	Nut
5	4	46664	Spring Washers
6	1	46665	Rear Plate
7	1	532	Vane
8	1	46666	Shaft
9	2	46667	Shaft Key
10	1	46668/46669	Rotor 1000/1400



## **Installation & General Maintenance**

1. Vibrators are delivered without lubrication. Ensure to add oil before starting vibrator.
2. Before connecting the vibrator, ensure the is clean from any dirt or water.
3. Once a day or every two hours of continuous use, introduce 4 cc of 20/30 S.A.E. non-detergent oil into the vibrator airline.
4. Ensure vibrator cradle (QR Bracket) is fully welded to the equipment and that the Swing Bolt is locked in position and nut tightened securely. Check this regularly.

## **Dismantling Instructions**

Remove hose from end of shaft (8). Remove Bolts (1) and spring washers (5). Using a soft drift, drive shaft (8) out of front plate (2). The shaft (8) will come out with the rear plate (6) still attached. The front plate (2) remains mounted in the vibrator body (3). Care must be taken not to drop and lose the keys (9) which may fall out of the shaft (8). Remove rotor (10) from the assembly. Clean all parts with paraffin and dry carefully. Check the length of the rotor (10) 100 - 0.06/0.08mm when new. Maximum wear of the rotors must not exceed 0.2mm as speed and power is greatly reduced. Check vane and replace with a new one if worn.

## **Re-assembly Instructions**

When fitting a new vane (7) ensure that it fits freely but snug in the groove of the shaft (8). If necessary, carefully sand down the thickness with fine emery paper. The top of the vane must be flush or slightly under the lip of the groove in the shaft. Lightly oil all parts. Place the body (3) with front plate (2) attached, on a bench with front plate downwards. Locate rotor (10) centrally in body (3). After re-fitting vane (7) in the groove of the shaft (8) fit keys (9) and insert shaft (8) with rear plate (6) attached through the rotor and locate in the front plate (2). Check alignment of key (9) in front plate (2) and tap together. Refit bolts and washers. Refit hose.

## **ATTENTION**

- Always ensure compressed air is off during installation or maintenance.**
- Always ensure only filtered air is used and the filter is cleaned regularly.**
- Always check the weld of cradles for fatigue cracks regularly.**
- Always check swing bolt is securely tightened regularly.**
- Always check tightness of hose connections regularly.**



***VAQ 1000 & 1400 are fitted to QR2 weld- on bracket***

## QR 2 & QR 4 Brackets

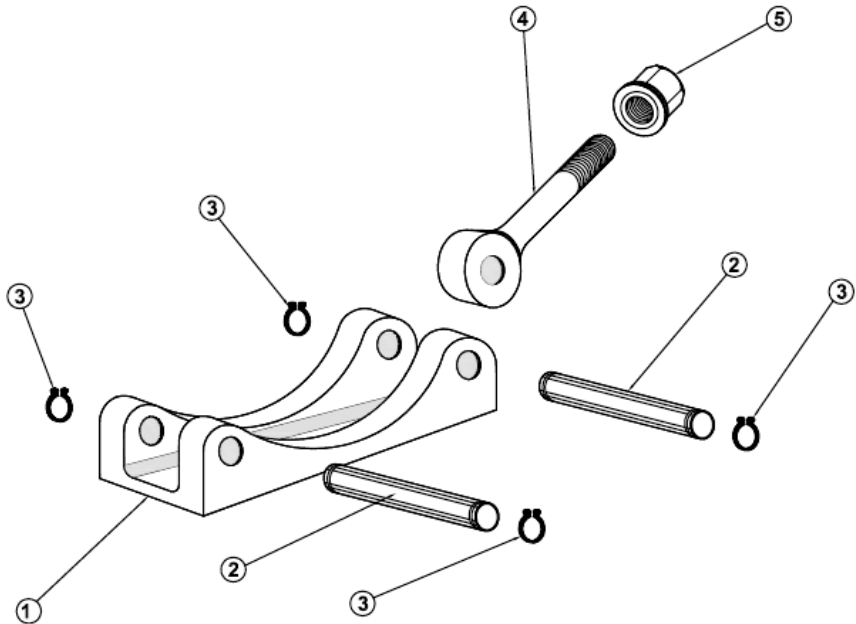

### Dimensions

Type	Length mm	Width mm	Weight Kgs
QR2	180	95	3.15
QR4	240	86	4.75

### Spare Parts

Item No.	Qty	Description	QR2 Part No.	QR4 Part No.
1	1	Cradle	2572	1915
2	2	Shaft	4365	4364
3	4	Circlip	4366	4293
4	1	Draw bolt	2573	1948
5	1	Draw nut	1935	1953

***VIBTEC***  
**VIBRATECHNIQUES LTD**  

---

---

---

*Vibration Solutions*

2 CHAPEL ROAD, PORTSLADE, BRIGHTON, BN41 1PF ENGLAND  
Tel. +44(0) 1273 430977 Fax. +44 (0) 1273 430978

Web. [www.vibtec.com](http://www.vibtec.com) E-mail. [sales@vibtec.com](mailto:sales@vibtec.com)