



Operating Manual

VPI 47 / VPK 47



Before putting into operation, make sure that the equipment does not show any signs of exterior damage.

Connect the **VPI 47** to a suitable 42v - 48v or 110v [250v] / 200 Hz frequency converter. The CEE-type plug connector fits most commercially available transformers.

Caution: Converters with output voltages different from those allowed for the equipment can lead to the destruction of the equipment or considerably impair its performance.

For model with hand switch:

Immerse the vibratory poker completely in the concrete and operate hand switch. As soon as the desired compatibility is reached, withdraw equipment and switch off.

For model with automatic switch:

Immerse the vibratory poker completely in the concrete. As soon as an angle of inclination of about 30° is reached, the automatic switch installed in the connection hose (at approx. 60 cm above the connection) is triggered. As soon as the desired compatibility is reached, withdraw equipment again and put that section of the hose that contains the switch in a horizontal position (for example by laying it on the ground) to cut off the vibrator.

For model VPK 47 with integral Inverter Control:

Connect the VPK 47 to a suitable 110v 1ph 50Hz supply. The CEE-type plug is standard for 110v connection.

The VPK 47 is fitted with a special version of the VPI 47 using a different stator, otherwise mechanically its the same and therefore can be serviced as described below.

The Inverter Control is a sealed unit and no servicing is necessary or possible.

Note: If the VPK range is being run off a generator the generator must be a regulated type. The electronics of the VPK switch box will only accept +/- 10% voltage variation. Spikes of over 150 volts will damage the switch box. Impact sensitive electronics are used in the switch box. Impacts over 100m/s² may damage the unit

To ensure proper cooling, all poker heads should be completely immersed in the concrete. Where this doesn't happen, it increases the risk of the integrated thermo - switch automatically cutting down the equipment to protect it from overheating. If this should happen, please allow time for the equipment to cool down before restarting. Immersing in a bucket of cold water would speed up this process.

Danger: HEALTH HAZARD Do not handle or touch vibrating part during operation

Dismantling: The replacement of defective components as well as any subsequent assembly must be carried out by skilled technicians. **Always disconnect equipment from power supply.**

To open vibratory poker, clamp the stator body [8] firmly in a pipe vice. Release locking weld points between nosepiece (13 / 15), vibrator housing (14) and the stator (8). This thread has been assembled using 'Loctite' or similar thread sealant. To release, heat the area, to a temperature of 100° C – 120° C, at the threaded point and unscrew steel head by using a pipe wrench (right-hand thread). The rotor is secured inside the vibrator housing (14). Clamp the eccentric weight part of the rotor assembly in vice using suitable jaw protection. Carefully lever the vibrator housing away using two suitable screwdrivers or levers to release the rotor assembly.

Screw an M8 studding into extraction nut (12) and pull needle bearing (10) out of stator. Repeating these steps, screw the studding into the extraction nut (6) and pull out second roller bearing (4) from the vibrator housing (14).

To continue dismantling the rotor assy, draw inner raceway of needle bearing (11) off the rotor (1), remove bearing and inner raceway (4,5) drive out spiral pin (3) slide off eccentric weight (2) remove other bearing and inner raceway (4, 5).

The assembly must be carried out in reverse order. The needle bearing [12] must be pre-lubricated.

When re-assembling, threads must be treated with 'Loctite' or similar thread sealant.

If possible re-weld locking points.

Lubrication The VPI 47 is oil-lubricated. Quantity 7 cm³

Technical Data:	VPI 47	VPK 47
Diameter	51mm	51mm
Length head	360mm	360mm
Weight (head only)	4.5 kgs	7.4 kgs (Head & Control less hose)
Input (voltage)	42-48v / 200 Hz	110v 1ph 50Hz
Output (Power)	1.4 kVA	1.1 kVA
Speed	12000 rpm	12000 rpm
Compaction rate	21 m ³ /h	21 m ³ /h
Length / rubber hose	5m	5m
Length / supply cable	10m	10m

VPI 47

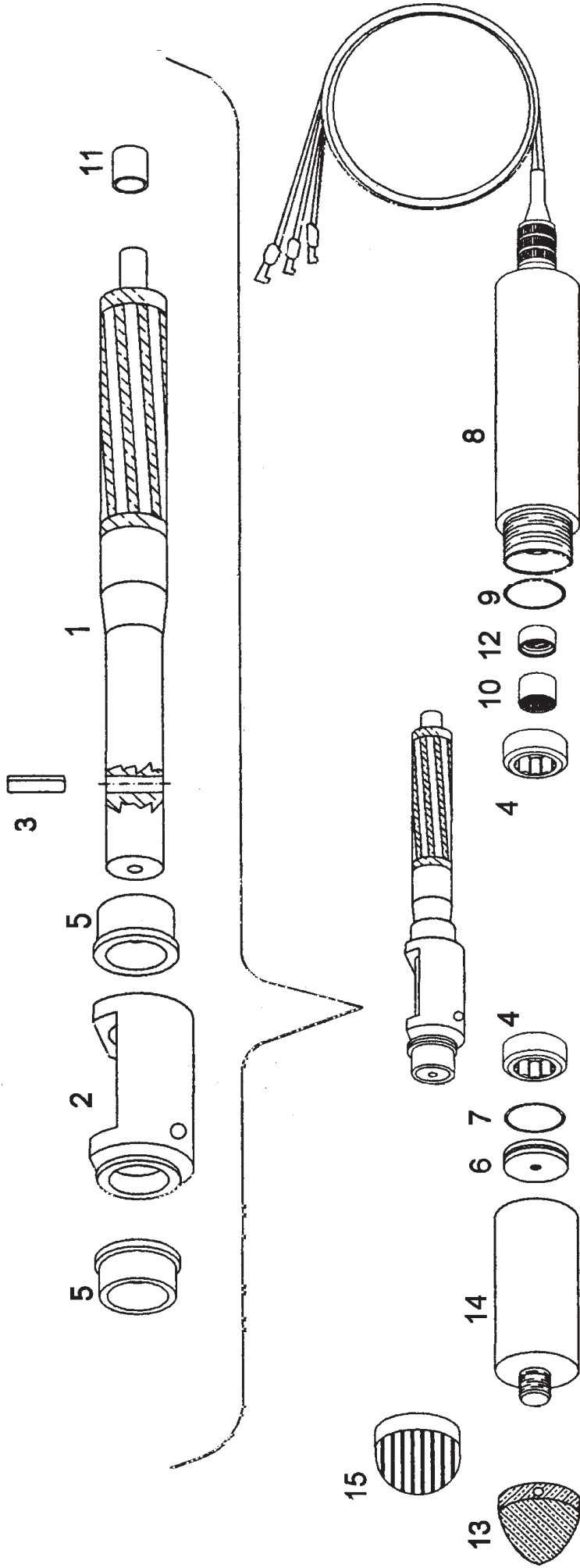

Item	Description	Ref. No.	Item	Description	Ref. No.
1	Rotor / 47	R1100	9	Inner 'O' ring stator / 47	R1109
2	Eccentric weight / 47	R1101	10	Needle bearing / 47	R1110
3	Spiral pin / 47	R1102	11	Inner raceway for needle bearing / 47	R1111
4 / 5	Roller bearing complete / 47	R1103	12	Extraction nut / 47	R1112
6	Extraction nut / 47	R1104	13	Steel nosepiece / 47	R1113
7	'O' ring of extraction nut / 47	R1105	14	Vibrator housing / 47	R1114
8	Stator 42v / 47	R1106	15	Rubber nosepiece (Vulcan) / 47	R1115
8	Stator 115v / 47	R1107			
8	Stator 250v / 47	R1108			