

**LEAK-MASTER® MAPMAX**



**Automatic in-line micro-leak detection system for packages based on CO<sub>2</sub>. LEAK-MASTER® MAPMAX features non-destructive detection of the smallest leaks without the need of costly helium - directly from the packaging line.**

CO<sub>2</sub> is the most important gas in the packaging of food under modified atmospheres. The LEAK-MASTER® MAPMAX uses this CO<sub>2</sub> as trace gas. That way it is possible to test the packages for leaks directly after the packing process.

The LEAK-MASTER® MAPMAX places the packages or complete shipping cases precisely in the test chamber. If the test sample is leaking, the pressure difference will result in a gas flow from the package into the chamber and the CO<sub>2</sub>-concentration within the chamber rises. The highly sensitive sensor will notice the changes of the CO<sub>2</sub>-concentration and even smallest leaks are easily detected.

After each test cycle (up to 15 cycles per minute) the chamber is ventilated and the test sample is moved on to the following system. If a leak has been detected, several potential free contacts for communication with external systems are available (e.g. alarms and/or pusher).

**Benefits**

- short response time
  - high operating speed (max. 15 cycles/min.)
  - for single packages or complete shipping cases
  - various chamber sizes
  - for flexible and rigid packs
  - no calibration required
  - easy-to-use intuitive system – no special skills required
  - operator friendly - data and process parameter entry by means of integrated PLC with touch-screen or via remote personal computer
  - convenient data administration and evaluation for customer oriented quality documentation
  - remote transmission of results via Ethernet
  - easy to clean stainless steel housing
- Other models, options and accessories available on request.**

**Product Information**

B01/B1 subject to change

**LEAK DETECTION SYSTEMS**

www.wittgas.com

<b>Type</b>	LEAK-MASTER® MAPMAX
<b>Drive Mechanism</b>	2 synchronized belt conveyors
<b>Measuring System</b>	infrared sensor for CO <sub>2</sub> (calibration not required)
<b>Measuring range</b>	0 ppm – 5.000 ppm (Resolution: 1 ppm)
<b>Response time</b>	approx. 1 sec.
<b>max. CO<sub>2</sub> concentration in ambient air</b>	2.500 ppm
<b>Leak testing cycle</b>	max. 15 measures/min. depends on leak size, CO <sub>2</sub> -percentage in package and size of chamber
<b>Operating vacuum</b>	min. 800 mbar abs., max. 200 mbar abs.
<b>Temperature range</b>	5 – 40 °C (41 – 104 °F)
<b>Humidity of ambient air</b>	max. 90% at 20 °C (68 °F) / max. 50% at 40 °C (104 °F)
<b>Alarms</b>	potential free contact; max. 250 V AC or 24 V DC / 2 A
<b>Communication</b>	- data communication via Ethernet - digital output for take-over cycle - digital output for pusher unit
<b>Compressed air connection pneumatic cylinder inlet for pneumatic valves</b>	1 x 14 mm (1 x 0.5 inch) min. 6 to 10 barg min. 6 to 10 barg
<b>Housing</b>	stainless steel
<b>Weight</b>	approx. 750 kg
<b>Machine dimension (HxWxD)</b>	
machine type 1	1700 x 1820 x 1385 mm (66.9 x 71.6 x 54.5 inch)
machine type 2	1700 x 1750 x 1107 mm (66.9 x 68.9 x 43.6 inch)
<b>Take-over-height (h1)</b>	
machine type 1	820 – 1.000 mm (32.3 – 39.4 inch)
machine type 2	815 – 985 mm (32.1 – 38.8 inch)
<b>Test volume (hxwx d)</b>	
machine type 1.1	approx. 140 x 410 x 650 mm (5.5 x 16.1 x 25.6 inch)
machine type 1.2	approx. 140 x 610 x 650 mm (5.5 x 24 x 25.6 inch)
machine type 2.1	approx. 230 x 330 x 400 mm (9 x 13 x 15.7 inch)
<b>Power consumption</b>	400 V - 50 Hz, 3 Ph/N/PE
<b>Optional</b>	discharge unit - pusher for leaky packages mounted on synchronized conveyor belt
<b>Approvals</b>	Company certified according to ISO 9001:2000, ISO 14001 and ISO 22000 CE-marked according to: - EMC 2004/108/EC - Low Voltage Directive 2006/95/EC - Machines Directive 2006/42/EC

Technical Data

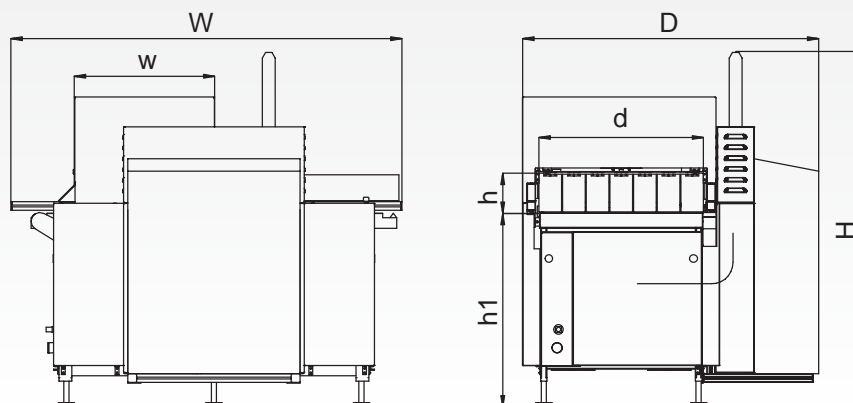

fig 1.1

B01/B1 subject to change