

PRESSURE REGULATOR

www.wittgas.com

ADR 150 FOR ACETYLENE

Powerful manifold pressure regulator to regulate high flows at acetylene cylinder manifolds or bundles (packs).

Benefits

- extremely low pressure drop (Δp) provide optimal draining of the manifold or bundle
> see dynamic expansion curve
- integrated relief valve (according to ISO 7291)
- the only one in the world with
 - 150 m³/h flow capacity
 - extremely stable outlet pressure
- integrated relief valve, pilot pressure regulator with pressure gauge and outlet pressure gauge

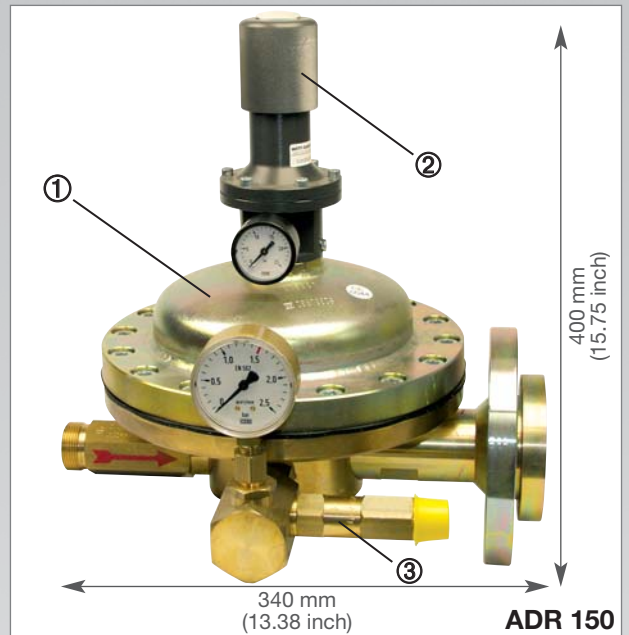

Operation / Usage

The ADR 150 for acetylene is used to reduce high pressure to working pressure in acetylene supplies as required in EN 14114.

Given the high regulating accuracy and flow specifications, it is suitable for all applications with high pressure requirements.

Function

The ADR 150 consists of a pilot pressure regulator (pilot gas = shielding or inert gas) in combination with a dome loaded pressure regulator and a relief valve. The required pipeline pressure is adjusted by the pilot pressure regulator to a maximum of 1.5 bar (2 bar available on request).

Maintenance

It is recommended that a leak check to atmosphere at regular intervals be conducted. Repairs are only to be carried out by the manufacturer.

Approvals

Company certified according to ISO 9001:2000 and ISO 14001
CE-marked according to:
- PED 97/23/EG, category III, Safety accessories

Product Information

Technical Data

	ADR 150 pressure regulator		
	Dome loaded pressure regulator ①	Pilot pressure regulator ②	Relief valve ③
Type	pneumatic pre-stressed	spring-loaded with secondary venting	spring-loaded with connecting thread for venting pipe
Gases	acetylene	shielding or inert gas as pilot gas	acetylene
max. inlet pressure	25 bar	10 bar	
min. inlet pressure		2 bar	
Outlet pressure	up to 1.5 bar (2 bar available on request)		
Nominal gas flow capacity	at 0.6 bar outlet pressure 96 m ³ /h at 1.5 bar outlet pressure 150 m ³ /h		
Inlet	M36x2, solderless pipe coupler, drill hole form W - heavy series S DN 25 - DIN 3861	G 1/4 female thread	
Filter	stainless steel, filter mesh 100 µm		
Relief valve capacity			according to nominal gas flow capacity
Outlet	flange, DN 50 – PN 40, DIN 2656	G 1/4 female thread	M24x1 female thread
Materials	brass, stainless steel, steel, elastomer	aluminium, brass, stainless steel, elastomer	brass, stainless steel, elastomer
Weight	approx. 25 kg		

PRESSURE REGULATOR

www.wittgas.com

ADR 150 FOR ACETYLENE

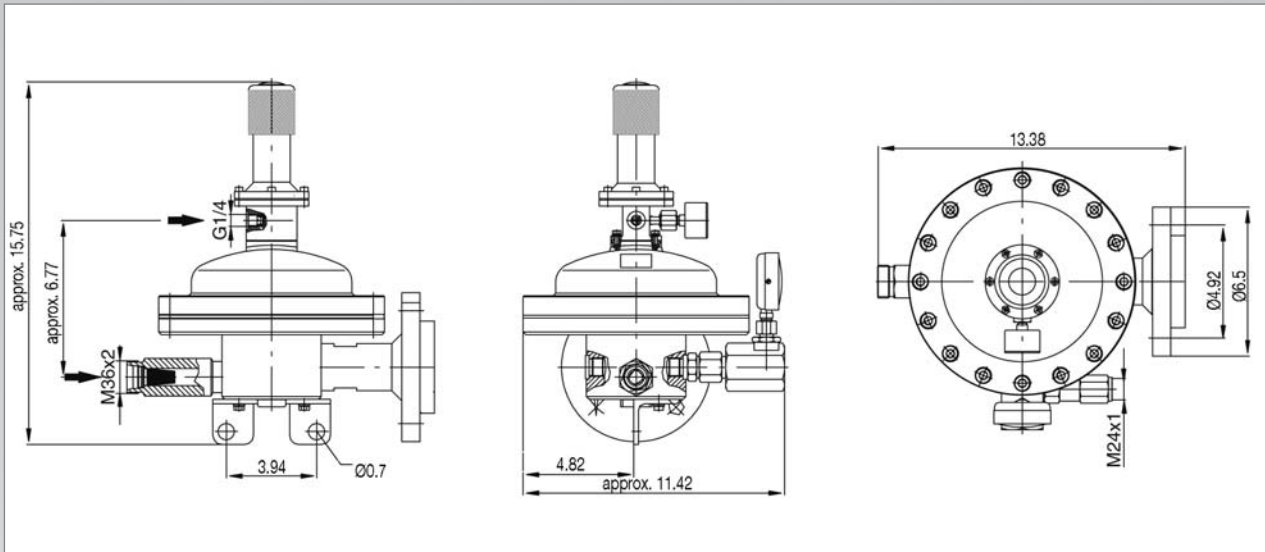

Flow diagram

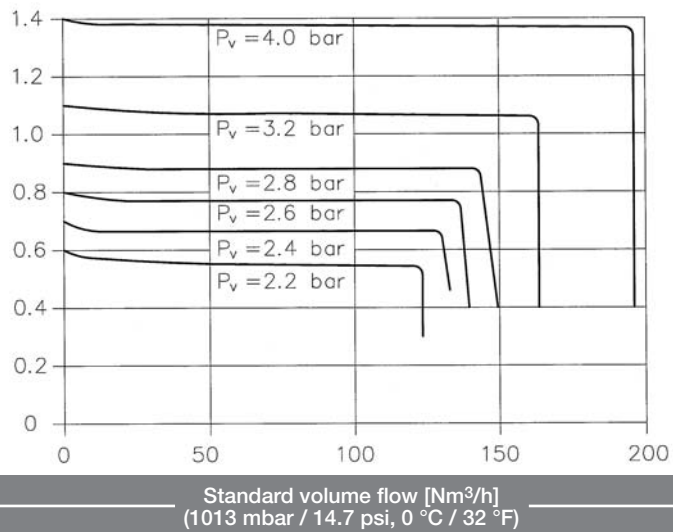

Outlet pressure: P_h [bar]

Dynamic expansion curve (1013 mbar / 14.7 psi, 0 °C / 32 °F)

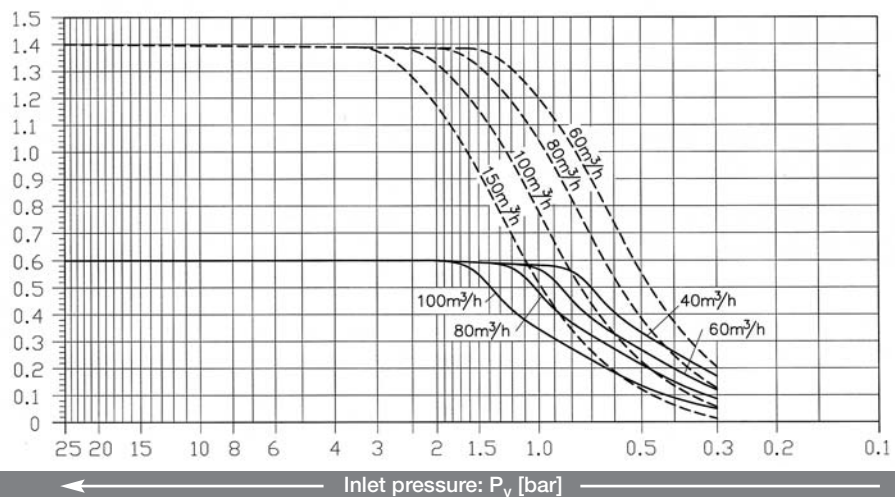

Outlet pressure: P_h [bar]

Inlet pressure: P_v [bar]

Technical Data

15 Subject to change