

EHLEVA
By Mobirol spa

Via C. Colombo, 22/a
42046 Reggio Emilia (RE) Italy

www.mobirol.it
mobirol@mobirol.it
www.ehleva.com
info@ehleva.com

Tel. +39 0522 973234
Fax +39 0522 973139

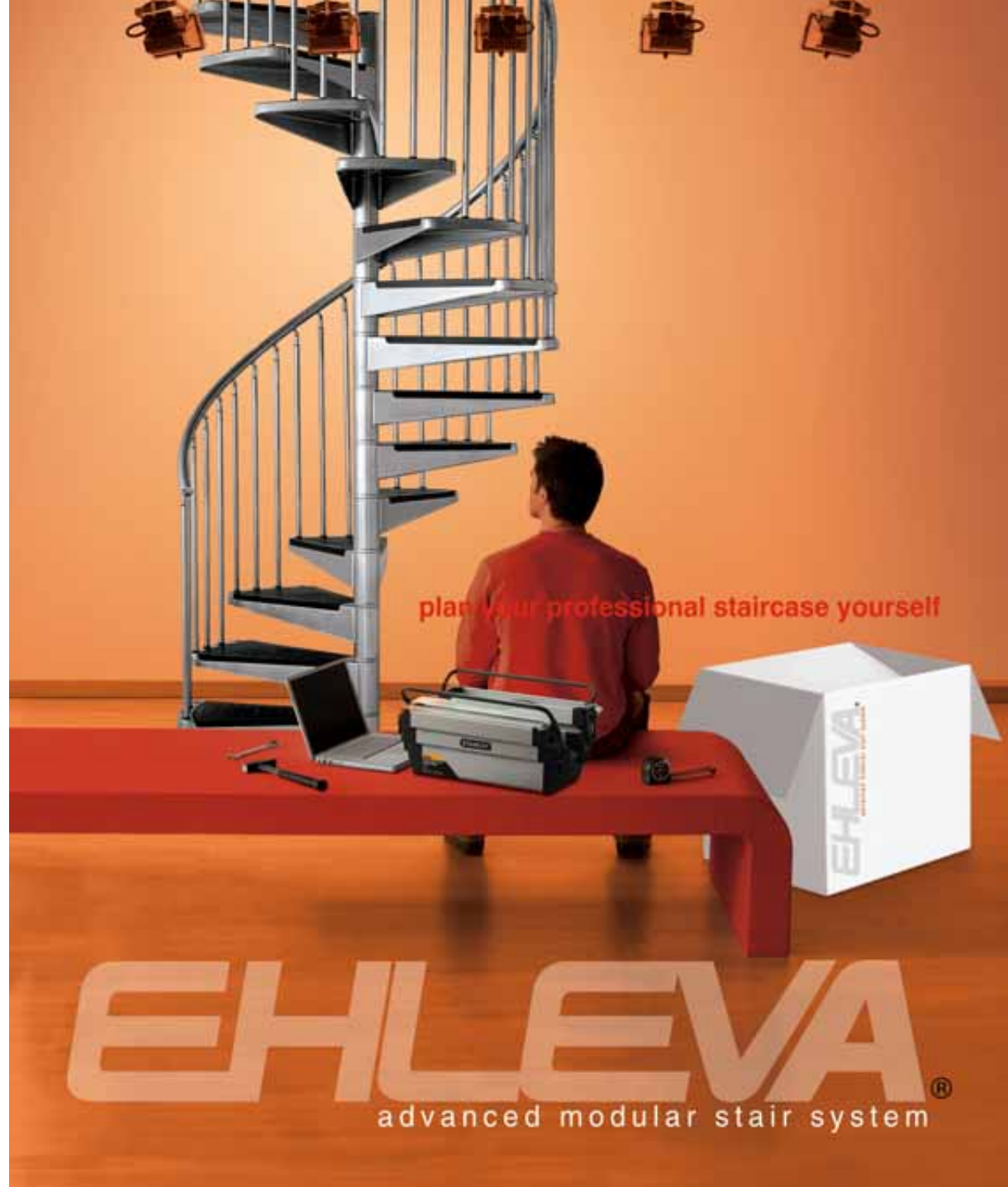

plan your professional staircase yourself

EHLEVA
advanced modular stair system

How to combine easy assembly and suitability for any environment and ensure the prompt availability of the product requested?

spiral staircases

fusion



pag 8

vogue



pag 12

motion



pag 14

optima



pag 18

open staircases

vector 70



pag 26

vector 80



pag 32

retractable staircases

vision



pag 38

How to combine easy assembly and suitability for any environment and ensure the prompt availability of the product requested? All this is now possible with the new EHLEVA staircase kit line! The staircases of the EHLEVA line were

designed to provide the best solutions to meet the most common needs of customers. All these products are easy to assemble and always available in stock. The available range of models and colours allows providing the most suitable

customised versions for any environment. The size is not an obstacle any longer thanks to the high **flexibility of EHLEVA products, which allows adjusting them to environments of any size.** The staircases are manufactured with

state-of-the-art materials and all their details are carefully studied so as to comply with the **newest design trends** and meet both classic and modern tastes. After all, the combination of beauty and simplicity has always been successful

VDEX



easy-to-assemble modular solutions

Each model comes with a detailed instruction manual and a useful video explaining how to assemble your staircase in less than one day without resorting to complex tools.

professional solutions ensuring maximum adjustability

What are the available sizes of the EHLEVA staircases?
The answer is: any size! Each model of this catalogue actually consists in a modular system: you can easily find solutions suitable for your needs in terms of size. Thanks to their remarkable versatility,

each EHLEVA model may be adjusted to any need in terms of space: **tall staircases are adjustable in terms of height and modular models also allow adjusting their tread.** A clockwise or anti-clockwise winding rotation may be implemented also during the installation.

safe solutions designed with avant-garde materials

The production of staircases entails knowing many materials and being able to process them. Our approach leads us every day to process very different materials: wood, stainless steel, aluminium and a wide range of newly-developed synthetic compounds. **In line with the new**

design trends, three different metal colours are available as well as three sets of accessories: Handrail kit, to increase safety; Step kit, to increase the height of your staircase; External handrail kit, for modular staircases not leaning on walls.

all the solutions you need are held in stock

Choosing quality today translates into investing in the future. Over a certain period of time starting from the purchase date, EHLEVA will ensure that all the elements composing the system remain available. In the future, this important service

will allow you to easily find the elements or accessories to complement, expand or modify your staircase. That is why you may claim to be the real designer of your EHLEVA staircase.

EHLEVA





EHLEVA

**SPIRAL
STAIRCASES
RANGE**

FUSION



EHLEVA

FUSION

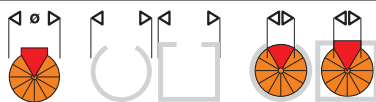

∅ stair ∅ well opening landing

FUSION-120	∅120	120,1 - 139	72,4 ÷ 83,2
FUSION-140	∅140	140,1 - 159	78,9 ÷ 88,9
FUSION-160	∅160	160,1 - 179	84,9 ÷ 94,3

Recommended well size: at least 5 cm bigger than the diameter of the staircase



13 risers standard stair	+1 kit riser	+2 kit riser
273,5-303,5 cm	294,5-327 cm	315,5-350,5 cm
Standard kit	option	option

tread kit - maximum height 350 cm

kit comprised of 9
spindles for balustrade
protection for circular or
square well

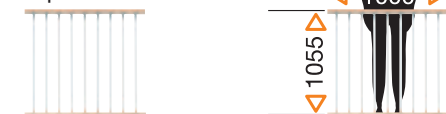

option

TREADS - HANDRAIL

Natural Beech

BANISTER - STRUCTURE

White

Grey

Black



Spiral staircase with steps in massive beech. Adjustable stair height, universal landing to be fitted to wells of any shape: round, square or for mezzanine floors.

clockwise and anticlockwise rotation



Packaging

Fusion-120
Kg. 190
m³0,85

Fusion-140
Kg. 210
m³0,85

Fusion-160
Kg. 230
m³0,85



EHLEVA

advanced modular stair system

VOGUE

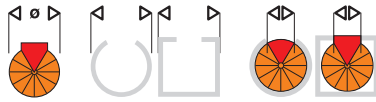

∅ stair ∅ well opening landing

VOGUE-120	∅120	120,1 - 139	72,4 ÷ 83,2
VOGUE-140	∅140	140,1 - 159	78,9 ÷ 88,9
VOGUE-160	∅160	160,1 - 179	84,9 ÷ 94,3

Recommended well size: at least 5 cm bigger than the diameter of the staircase



13 risers standard stair	+1 kit riser	+2 kit riser
273,5-303,5 cm	294,5-327 cm	315,5-350,5 cm
Standard kit	option	option

Tread kit - maximum height 350 cm

protection balustrade
kit - 4 spindles
for circular or square well



option

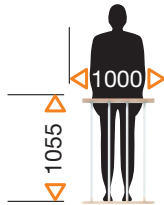

TREADS - HANDRAIL

Natural Beech

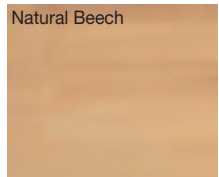

BANISTER - STRUCTURE

White

Grey

Black



Spiral staircase with steps in massive beech. Adjustable stair height, universal landing to be fitted to wells of any shape: round, square or for mezzanine floors.

clockwise and anticlockwise rotation



Packaging

Vogue-120
Kg. 190
m³ 0,85

Vogue-140
Kg. 210
m³ 0,85

Vogue-160
Kg. 230
m³ 0,85



EHLEVA

advanced modular stair system

MOTION



EHLEVA

MOTION

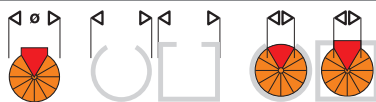

∅ stair ∅ well opening landing

MOTION-120	∅120	120,1 - 139	65,5
MOTION-140	∅140	140,1 - 159	74,6
MOTION-160	∅160	160,1 - 179	83,7

Recommended well size: at least 5 cm bigger than the diameter of the staircase



13 risers standard stair	+1 kit riser	+2 kit riser
273,5-303,5 cm	294,5-327 cm	315,5-350,5 cm
Standard kit	option	option

Tread kit - maximum height 350 cm

kit comprised of 9 spindles for balustrade protection for circular or square well

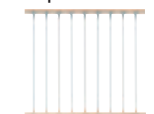

option



TREADS - HANDRAIL

PVC Black

BANISTER - STRUCTURE

White

Grey

Black



Steel spiral staircase.
Adjustable stair height, universal landing to be fitted to wells of any shape: round, square or for mezzanine floors.

clockwise and anticlockwise rotation



Packaging

Motion-120
Kg. 180
m³ 0,79

Motion-140
Kg. 210
m³ 0,79

Motion-160
Kg. 250
m³ 1,20



EHLEVA

OPTIMA

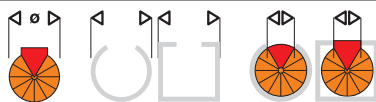

∅ stair ∅ well opening landing

OPTIMA-120	∅120	120,1 - 139	65,5
OPTIMA-140	∅140	140,1 - 159	74,6
OPTIMA-160	∅160	160,1 - 179	83,7

Recommended well size: at least 5 cm bigger than the diameter of the staircase



Steel spiral staircase with hot galvanized metal parts.

Adjustable stair height, universal landing to be fitted to wells of any shape: round, square or for mezzanine floors.

clockwise and anticlockwise rotation



Packaging

Optima-120
Kg. 180
m³ 0,79

Optima-140
Kg. 210
m³ 0,79

Optima-160
Kg. 250
m³ 1,20



13 risers standard stair	+1 kit riser	+2 kit riser
273,5-303,5 cm	294,5-327 cm	315,5-350,5 cm
Standard kit	option	option

Tread kit - maximum height 350 cm

kit comprised of 9 spindles for balustrade protection for circular or square well



option

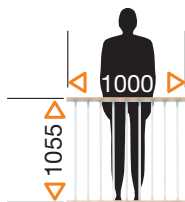

HANDRAIL

PVC Black

BANISTER - STRUCTURE

Galvanized

advanced modular stair system



EHLEVA



EHLEVA

**OPEN
STAIRCASES
RANGE**



VECTOR



EHLEVA

VECTOR

While fitting the kit stairs Vector can be adjusted in the riser (a), in the going (p) and in the rotation (clockwise and anticlockwise). Staircase available in **152** shapes (L/U). Supplied with 12 treads and 13 risers, handrail on the external side.

VECTOR 70

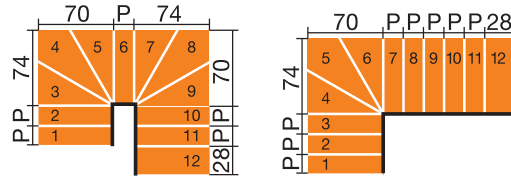

riser: 18 a 23.5 cm
going: da 20 a 23 cm

VECTOR 80

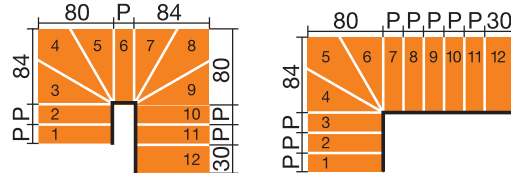

riser: 18 a 23.5 cm
going: da 22 a 25 cm

Modular stairs Vector are made of steel modules and railing available in the following colours:
WHITE
GRAY
BLACK
Steps and handrails are made of massive beech with natural finish. The other plastics-made parts are finished in grey.

12 treads 13 risers	+1 kit riser	+ 2 kit riser	+ 3 kit riser
Standard kit	option	option	option

Tread kit - maximum height 373 cm

Rotation



External railing kit to be ordered in case of dangerous gaps between the stair and the wall. It is made of 3 spindles, handrail and fixings.

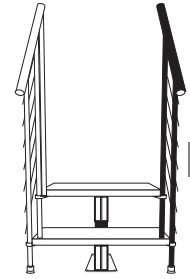

option

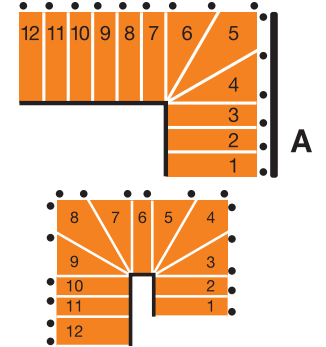

VECTOR example of configuration

To fit the external banister (VECTOR side A) you need 2 kits of additional banister.

TREADS - HANDRAIL	BANISTER - STRUCTURE
Natural Beech	White
	Grey
	Black

Protection balustrade kit - 4 spindles for circular or square well



option

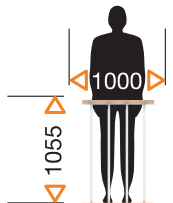

VECTOR 70

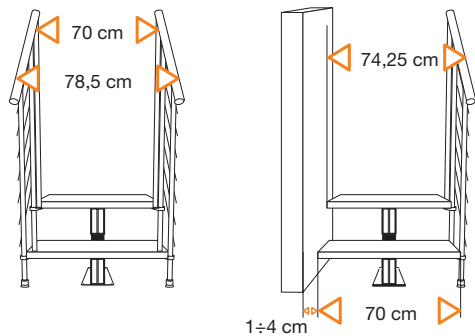

Wide flexibility of VECTOR 70: through adjustable tread (p) and riser (a) you can obtain 76 different configurations of the stair, thus fitting it to any kind of existing well. You can see the maximum shape sizes in the following diagram.



12 treads 13 risers	+1 kit riser	+ 2 kit riser	+ 3 kit riser
236,5-302,5 cm	254,5-326 cm	272,5-349,5 cm	290,5-373 cm
Standard kit	option	option	option

Tread kit - maximum height **373 cm**

options External balustrade kit

TREADS - HANDRAIL

Natural Beech

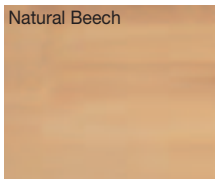

BANISTER - STRUCTURE

White

Grey

Black



adjustable riser from 18 to 23.5 cm



adjustable tread from 20 to 23 cm



clockwise and anticlockwise rotation



Packaging

Vector 70
Kg. 250 - m² 0,79

advanced modular stair system



EHLEVA

VECTOR 70

12 treads

13 risers

EHLEVA suggests

Recommended well opening should have the span of the stair less two steps as minimum dimensions.

If the well opening is already existing, find among the different configurations the first one with dimensions lower than the well opening.

If the well opening hasn't already been performed, look for the stair configuration that best fits in your space.

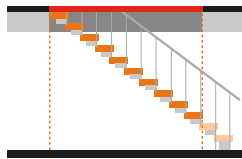

Well opening

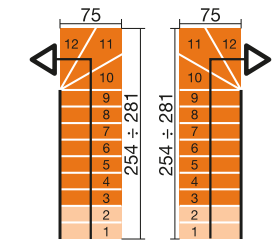
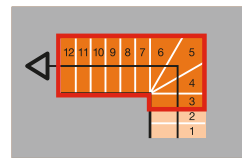

1

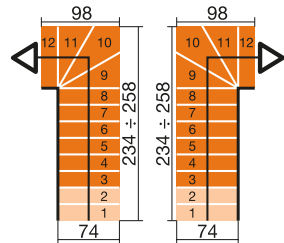

2

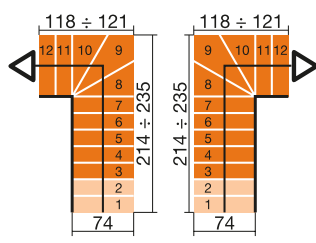

3

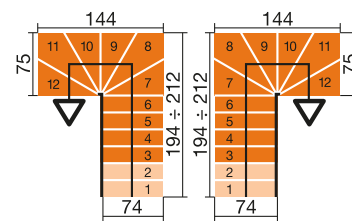

11

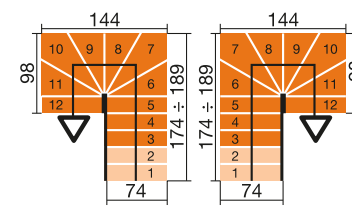

12

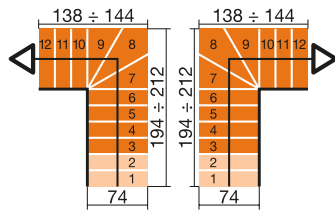

4

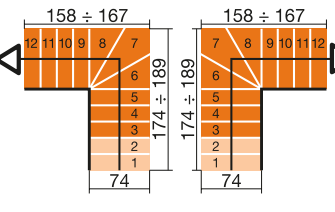

5

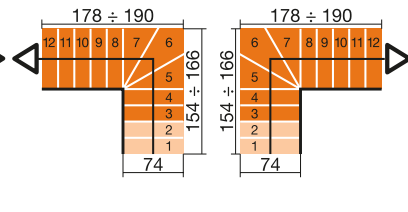

6

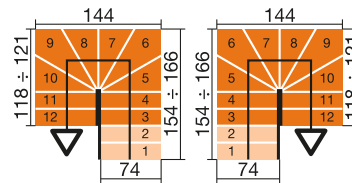

13

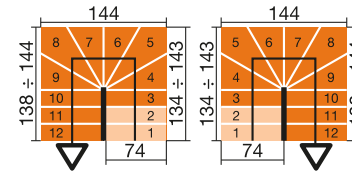

14

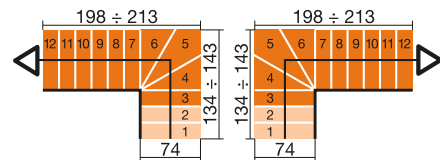

7

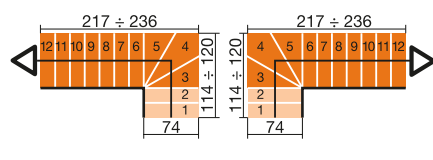

8

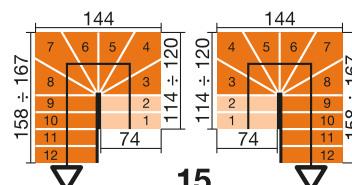

15

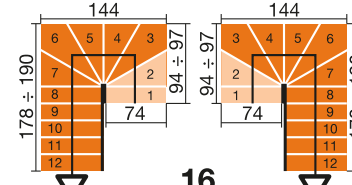

16

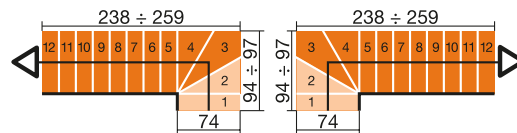

9

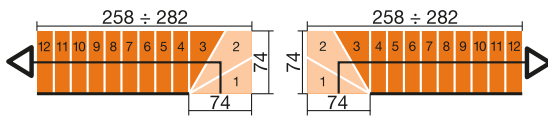

10

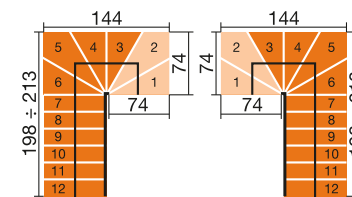

17

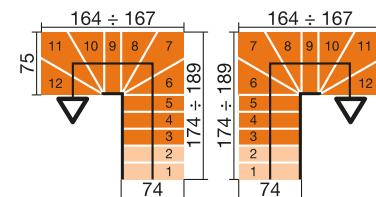

18

VECTOR 70

12 treads

13 risers

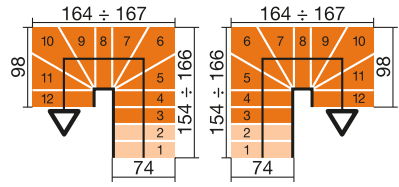

19

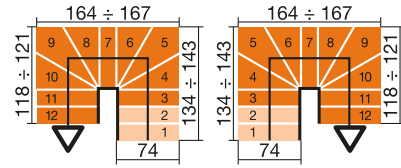

20

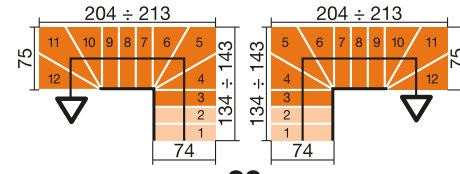

29

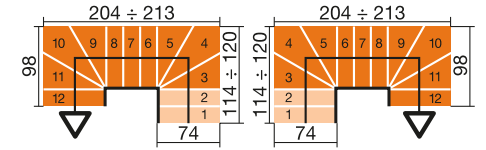

30

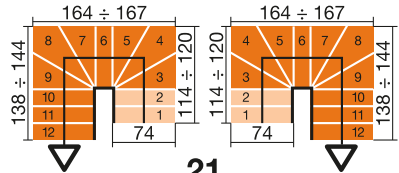

21

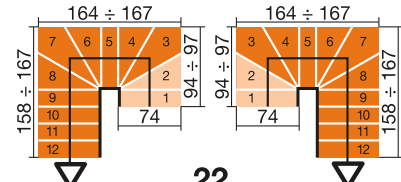

22

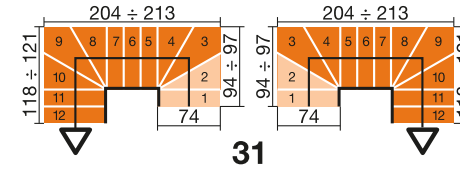

31

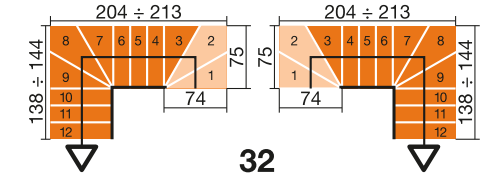

32

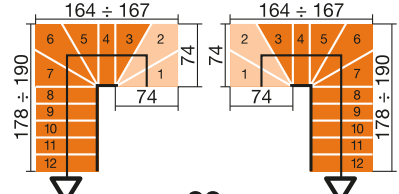

23

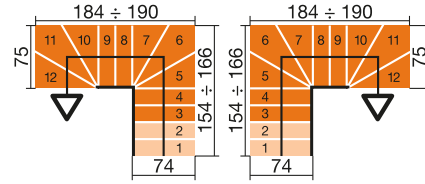

24

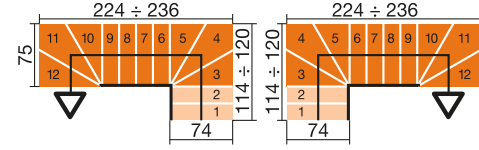

33

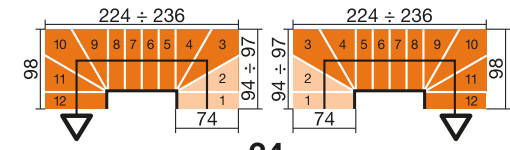

34

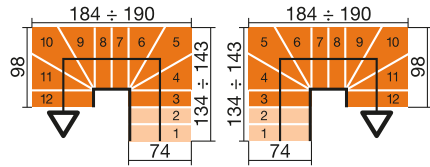

25

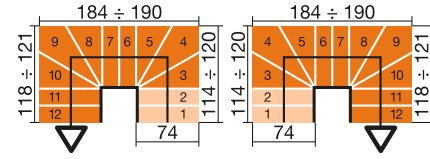

26

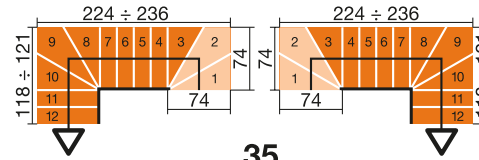

35

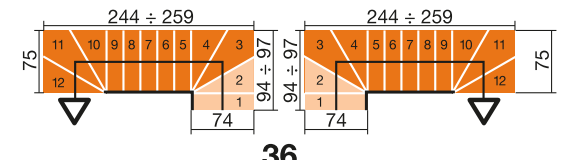

36

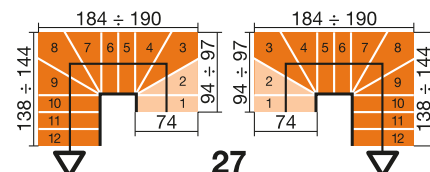

27

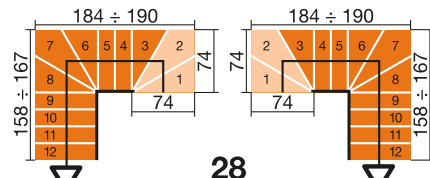

28

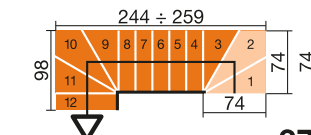

37

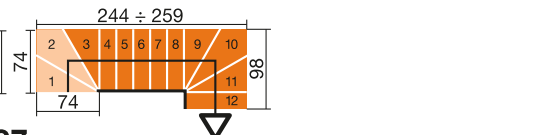

38

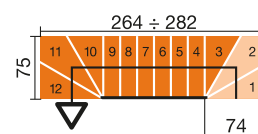

38

VECTOR 80

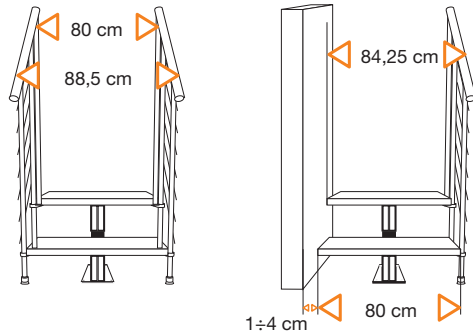

Wide flexibility of Vector 80: through adjustable tread (p) and riser (a) you can obtain 76 different configurations of the stair, thus fitting it to any kind of existing well. You can see the maximum shape sizes in the following diagram.



12 treads 13 risers	+1 kit riser	+ 2 kit riser	+ 3 kit riser
236,5-302,5 cm	254,5-326 cm	272,5-349,5 cm	290,5-373 cm
Standard kit	option	option	option

Tread kit - maximum height **373 cm**

options External balustrade kit

TREADS - HANDRAIL

Natural Beech

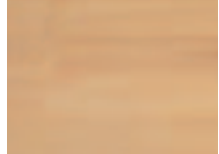

BANISTER - STRUCTURE

White



Grey



Black



adjustable riser from 18 to 23.5 cm



adjustable tread from 22 to 25 cm



clockwise and
anticlockwise rotation

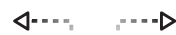

Packaging

Vector 80
Kg. 260 - m² 0,79



EHLEVA

EHLEVA suggests

Recommended well opening should have the span of the stair less two steps as minimum dimensions.

If the well opening is already existing, find among the different configurations the first one with dimensions lower than the well opening.

If the well opening hasn't already been performed, look for the stair configuration that best fits in your space.

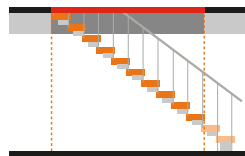

Well opening

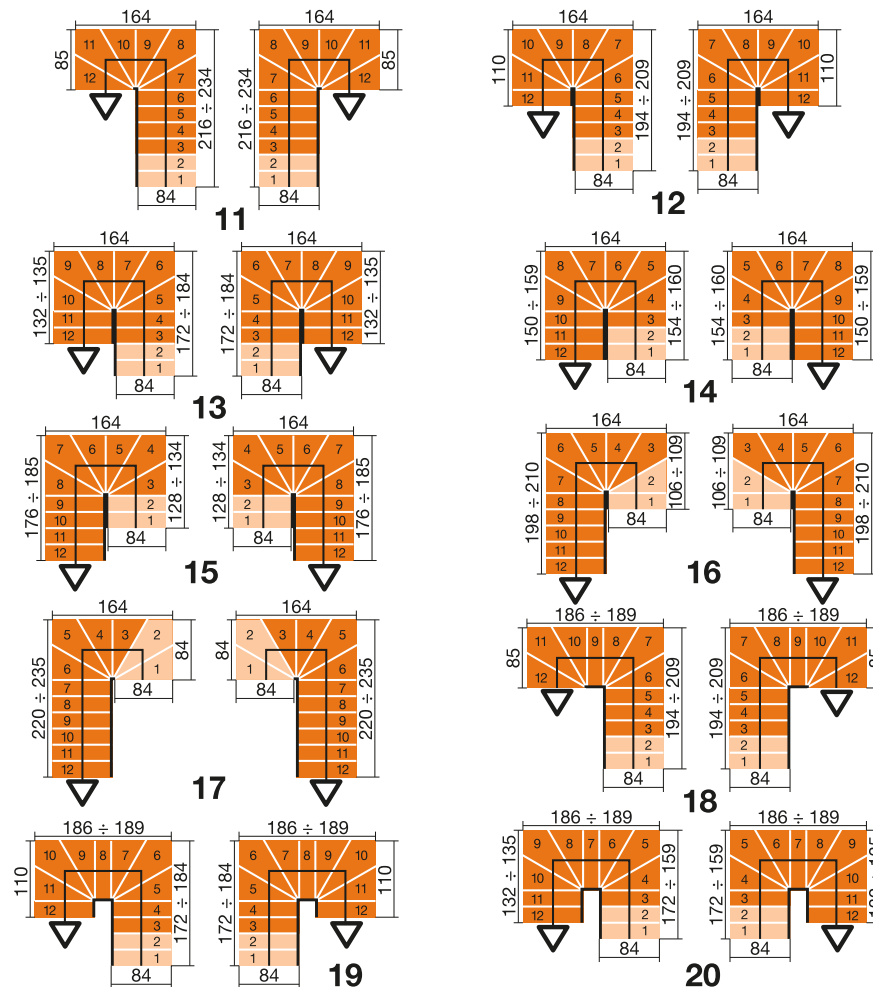
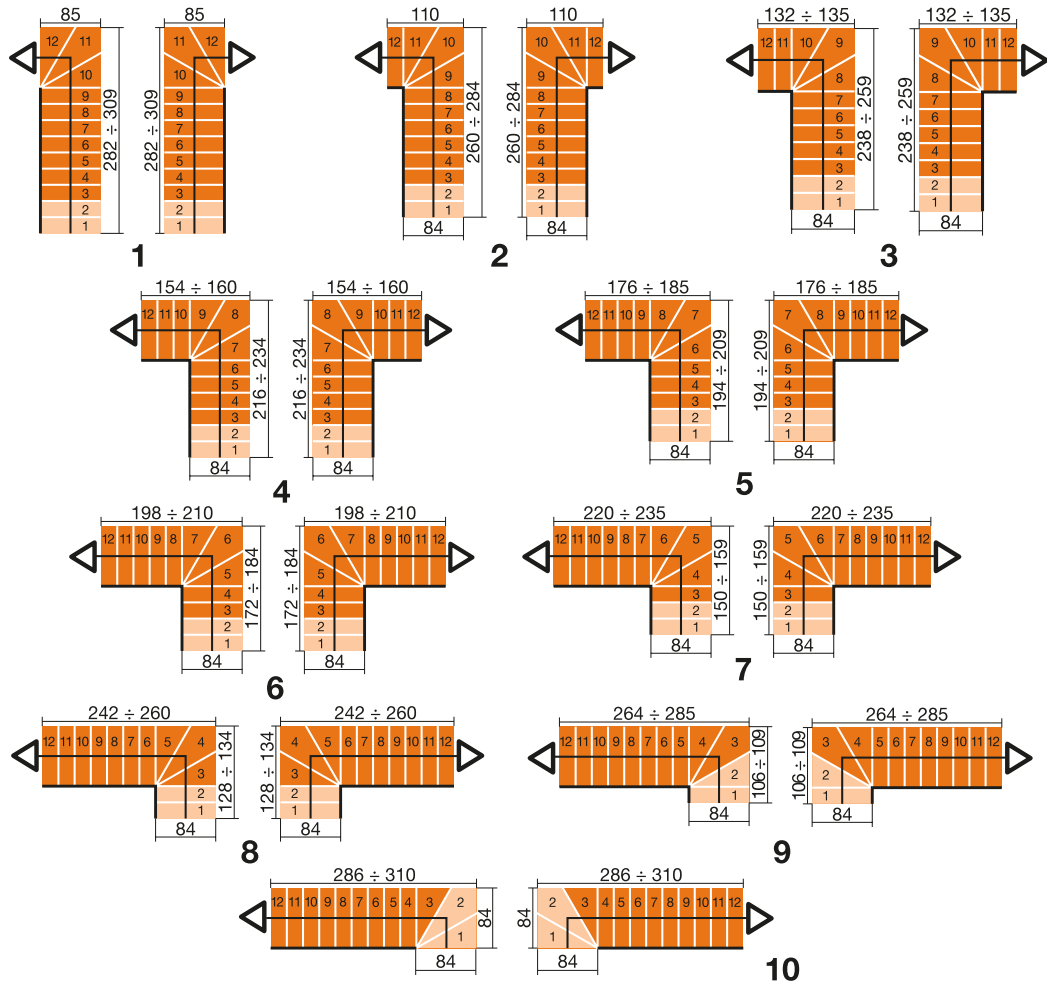
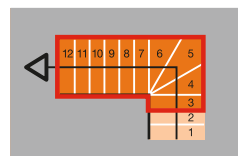

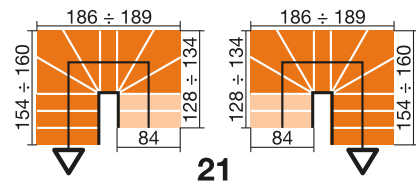

21

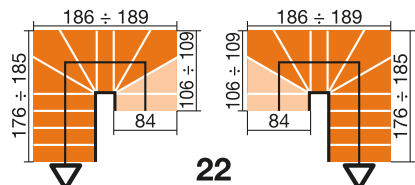

22

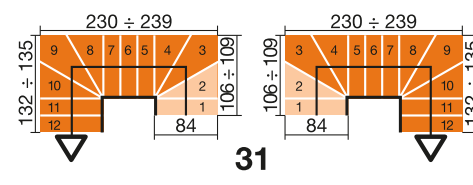

31

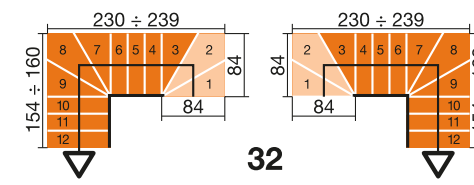

32

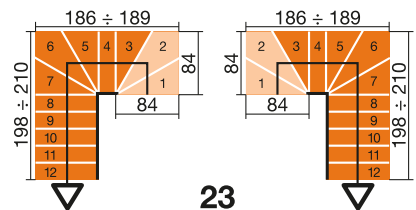

23

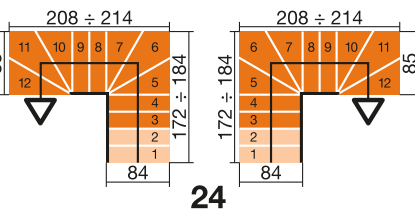

24

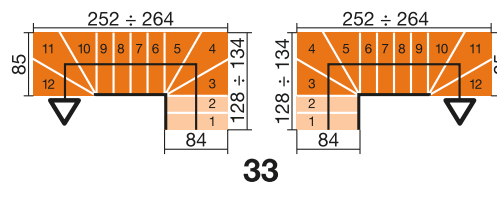

33

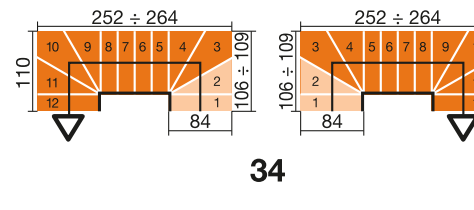

34

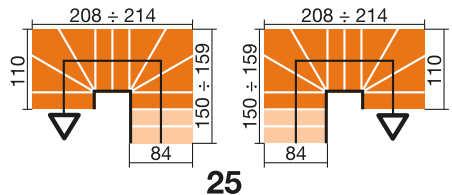

25

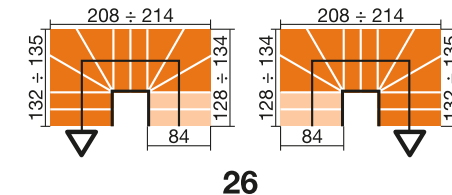

26

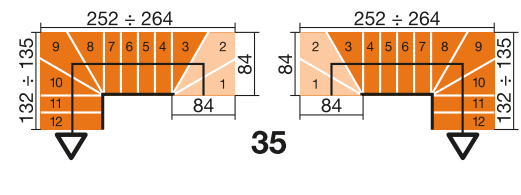

35

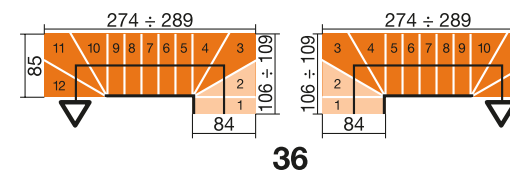

36

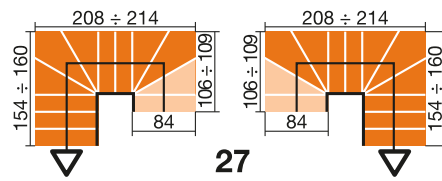

27

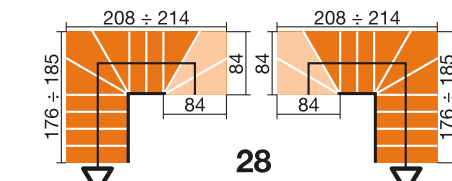

28

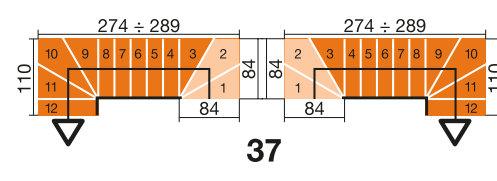

37

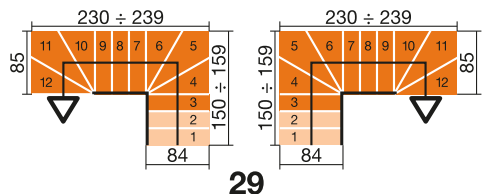

29

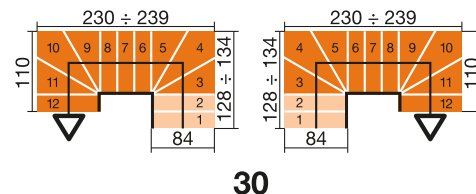

30

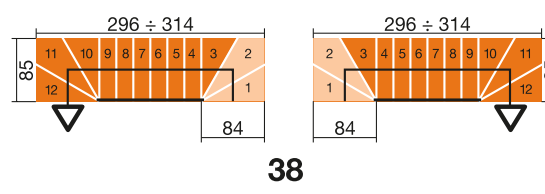

38

VISION

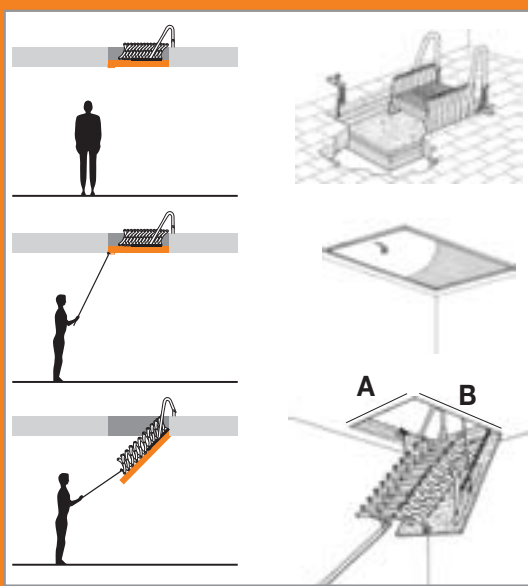

Retractable staircase for attics with balanced manual operation.

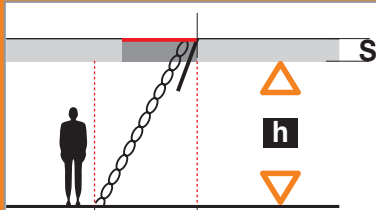

h	251
	300
BxA	80x50
	90x50
	90x70
	100x70
	120x70
E	170
S	25

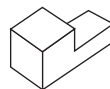

Packaging

Retractable stair for opening 80x50
Kg. 34

Retractable stair for opening 90x50
Kg. 36

Retractable stair for opening 90x70
Kg. 46

Retractable stair for opening 100x70
Kg. 48

Retractable stair for opening 120x70
Kg. 52

advanced modular stair system

