



The SpaceSaver Dust Collector



An energy efficient dust collector for those with limited available headroom or footprint space



Introducing the SpaceSaver - Next Generation Filtration

The first choice for those with limited space!

The SpaceSaver is an ideal energy efficient dust collector for those with limited space both from a footprint and overall height standpoint. The small, compact size of this collector allows for it to fit into some very tight spaces where dust collection is needed.

The SpaceSaver's elements are tool-free and easy to maintain. This collector is ideal for light grain loading applications up to 10gr/dscf. Additionally, this collector is a maintenance saver because it has fewer elements than a traditional dust collector and requires only a one-piece cartridge, as opposed to a bag and cage combination. The cartridges used in this collector are made out of spun bond polyester polipelet that is both washable and durable.

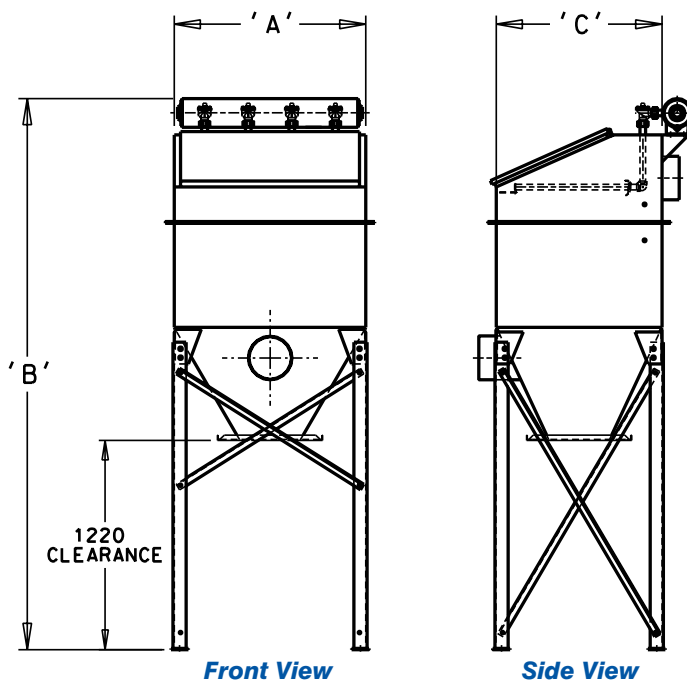

Model	No. of Cartridges	Media Area (m ²)	'A' (Width)	'B' (OAH)	'C' (Depth)
MSS2	2	21.2	685	3085	965
MSS3	3	31.8	865	3085	965
MSS4	4	42.4	1120	3210	965
MSS6	6	63.5	955	3545	1740
MSS8	8	84.7	1220	3545	1740
MSS12	12	127.1	1905	3755	1740
MSS16	16	169.5	2440	4040	1740
MSS20	20	211.8	3125	3755	1740
MSS24	24	254.2	3660	3755	1740
MSS28	28	296.5	4345	4040	1740
MSS32	32	338.9	4875	4040	1740
MSS40	40	423.6	6095	4040	1740
MSS48	48	508.4	7315	4040	1740

NOTES:

1. All dimensions are in millimetres.
2. When cartridge service door is open, allow an additional 400mm to the overall height for the MSS2-4 and 500mm for the MSS6-48.
3. Timer enclosure (shipped loose) requires 220 vac, 110 vac or 24 vdc power supply.
4. 6.2<7 Barg clean, dry compressed air required.
5. Filter housing rated for -50 mbar.

What could be more practical?

The SpaceSaver is ideally suited for a wide range of applications including: grain transfer and processing, fertilizer, cement, food minerals, mining, coal handling and woodworking.

MAC's SpaceSaver redefines dust collection. Compared to conventional systems, it offers a host of money-saving advantages:

- ▶ Fewer elements than traditional collectors
- ▶ Small, compact size
- ▶ Tool-free and easy to maintain
- ▶ Small footprint
- ▶ Superior cleaning mechanism
- ▶ Robust cartridges that are washable and durable

SpaceSaver Applications:

- ▶ Bucket Elevator Aspiration
- ▶ Belt Conveyor Transfer Points
- ▶ Mixer Ventilation
- ▶ Scale Hopper Ventilation
- ▶ Super Sack Fillers & Unloaders
- ▶ Silo Venting
- ▶ Hammer Mill Aspiration
- ▶ Seed Cleaning
- ▶ Ventilation of Wood Working Machinery
- ▶ General Dust Collection

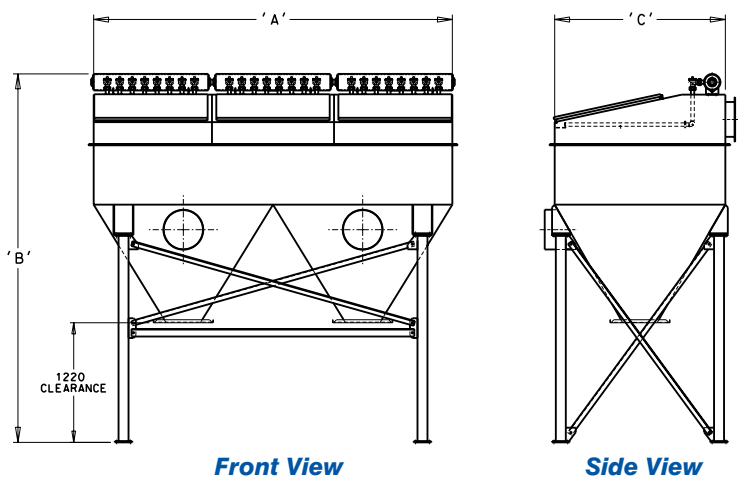
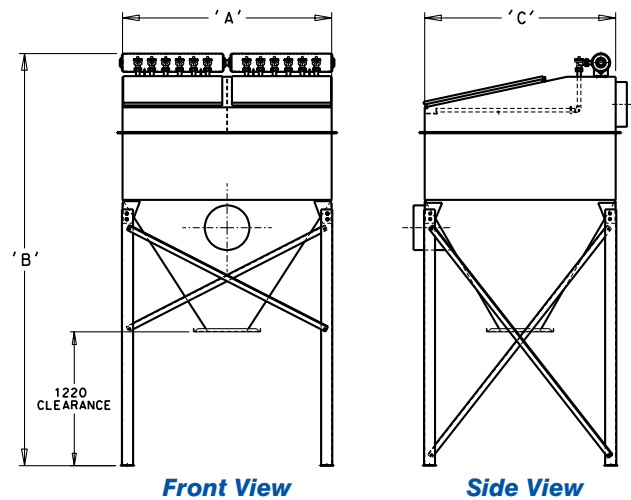

Superior Cleaning Mechanism

The SpaceSaver uses directed air flow to clean the cartridge leading to longer cartridge life and efficient use of compressed air. Many conventional dust collectors on the market today use no directed air flow which reduces the cleaning effectiveness, shortens the lifespan of the cartridge and wastes compressed air.





Experience and Excellence

Through its alliance with its sister company, MAC Equipment, Clyde Materials Handling has 40+ years of experience in developing and implementing customised air filtration solutions that strive to reduce energy and maintenance costs, reduce the emission of dust and harmful pollutants while helping customers improve productivity. MAC Equipment has become an internationally recognised leader in industrial air filtration.

Parent company Clyde Process Solutions plc, a public company listed on UK's AIM stock market, includes both Clyde Materials Handling and MAC Equipment businesses. Between the two, the group employs over 500 people from locations in the UK, US, Brazil, China, South Africa and India. Clyde's expertise in developing innovative solutions is complemented by its strong capabilities in design study, testing, project management and after sales service.



Contact Us

Clyde Materials Handling has global coverage through direct offices and representatives. Please contact us if you wish to speak to a Clyde industrial air filtration expert or to a representative in your region.



Clyde Materials Handling
INCORPORATING MAC EQUIPMENT

Carolina Court, Lakeside
Doncaster, DN4 5RA

Tel: +44 (0) 1302 321 313
Fax: +44 (0) 1302 554 400

E-mail: mac@clydematerials.co.uk