

In-line Solenoid Shotbolt

Type 62,63

Function

- energise-to-lock (T62) or spring-to-lock (T63)
- adjustable bolt position switch
- integral manual over-ride
- DC or AC supply
- 15mm bolt stroke

Standard features

- enclosed, weatherproof construction designed to IP65
- coil insulation class F, maximum voltage 250V
- flange mounting, installation in any attitude
- slam-shut/lock when closed
- flat-ended bolt or chamfered for slam-shut operation
- high performance, corrosion resistant, maintenance-free bearings
- corrosion resistant anodised aluminium case
- manual override on each side

Options

- special fascia plates and door-proving switches
- alternative bolt lengths
- alternative switch arrangements
- right-angle design (for reduced dimension on axis of bolt travel)

Applications

- access control
- security vehicles
- general industrial interlocking applications
- access and platform lifts for DDA

Standards

- solenoid designed and tested to VDE 0580
- ISO 9001
- EMC directive 2004/108/EC



Fig. 1 T63 Shotbolt

Type 62, 63			
Operating mode - Duty Rating ED		S1 100%	
Stroke s (mm)		Magnetic force F _M (N)	Spring return- force (N)
	0	40	24
	15	21	10
Rated Power P ₂₀	Stroke (W)	134	
	Hold (W)	6.5W	
Weight	(kg)	1.9	
Radial bolt load, max allowable	(N)	3000*	

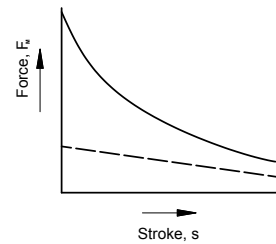

Fig. 3 Force characteristic

Table Notes

0mm is completion of energised stroke

Force figures F_M are gross. For net values deduct spring force

* The bolt will not withdraw if a side-load is present.

Table Basis

The terms used are defined in Technical Explanation GXX

Magnetic forces F_M stated are based on

- 24v 5% /100% duty coil
- working in the Hot condition
- 90% of the rated voltage
- 35°C ambient temperature
- armature in horizontal attitude
- heat-insulated mounting

Duty Rating ED, % of energised time/cycle:

$$100\% : \text{continuous duty} \quad \frac{t(\text{on})}{t(\text{on}) + t(\text{off})} \times 100$$

Rated Power P₂₀ stated with coil at 20°C

Values given may vary by up to ±10% owing to inherent and manufacturing tolerances

Shotbolts Type 62,63 incorporate solenoid GFCX040X00E23. For solenoid performance and other details refer to data sheet 'GFC'.

Supply Voltage

Standard voltage 24v DC

Other voltages upon request

Safety

The customer is responsible for ensuring that devices are suitable for their application and that, even if they should fail, safety in use is not compromised. We supply Technical Explanation documents to help users understand our products and assistance is always available from our technical department

Versions

Other shotbolt types are available – see respective data sheets

Also, special and modified versions, including

- ATEX
- right-angle lock
- special finishes
- long strokes

Contact our technical department for assistance

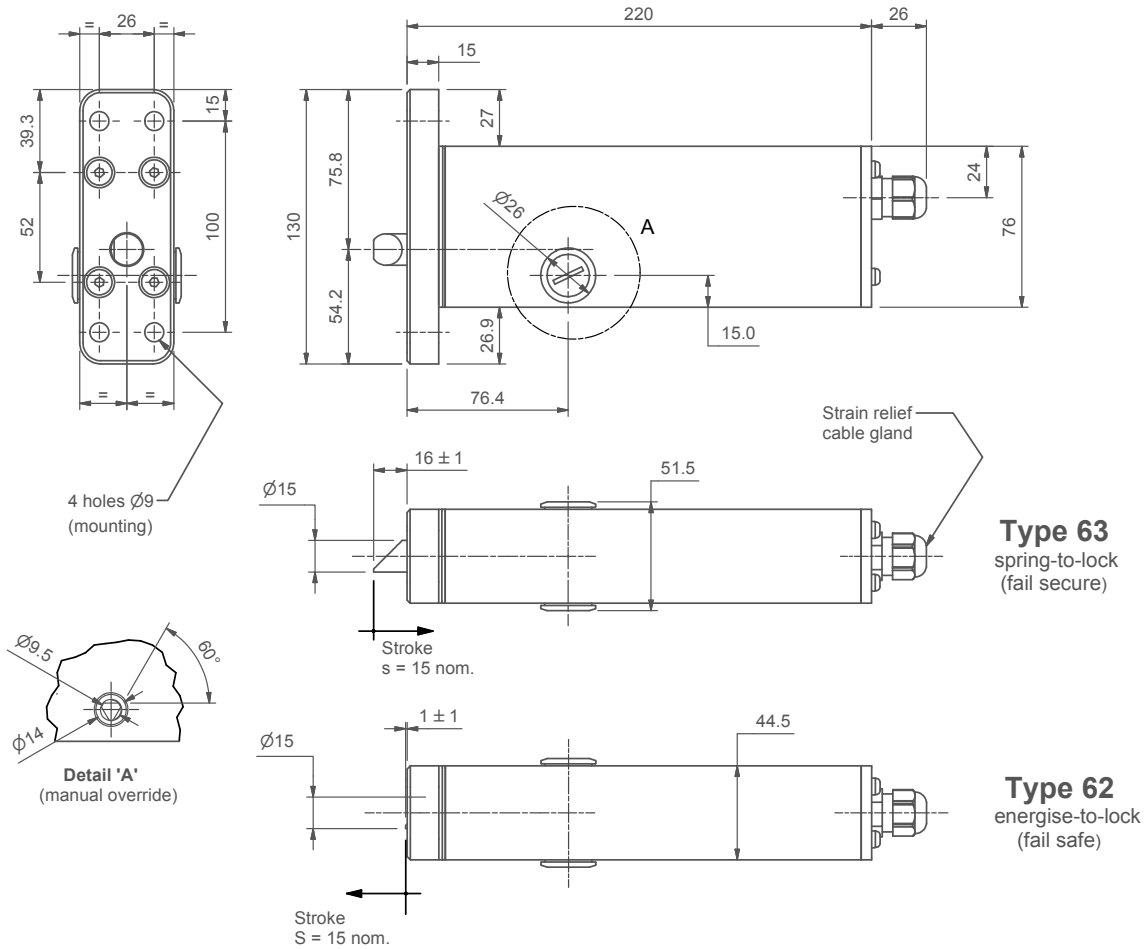

Fig. 4 Dimensions

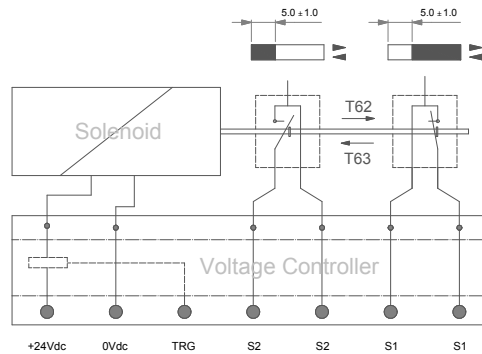

Fig. 5 Circuit schematic

Connection and Switch

Both Type 62 (energise-to-lock) and Type 63 (spring-to-lock) shotbolts incorporate 2 switches of type:

- Positive break (forced contact) switch $\pm 24V$ 0.5A – see Fig 5.

The switches are set as standard at 5.0 ± 1 mm protrusion from the mounting datum. Other switch set positions and types can be provided on request.

The circuit provides for switching of the unit from an external relay via the trigger contact TRG.

If operating directly from the supply, place a link between +24v and TRG

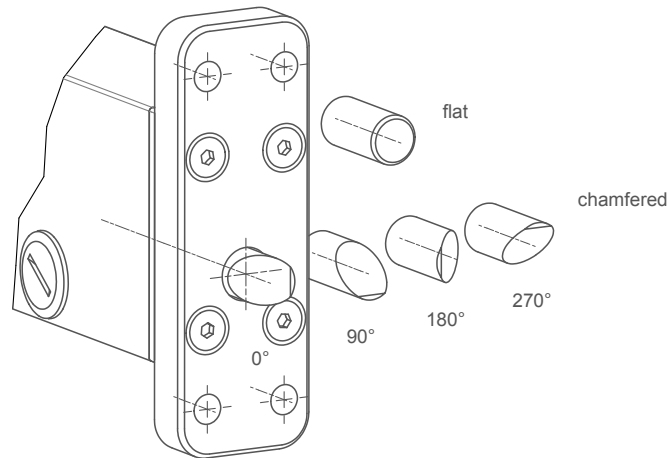

Fig.7 Bolt options

Order example: **T63 GFCX040 CH 0° 24V 100%**

Order codes table:

Order Example	T63	GFCX040	CH	0°	24v 100%
Group and function type	T62 - Energise-to-lock T63 - Spring-to-lock				
Solenoid type		GFCX040			
Bolt design			CH - chamfered FL - flat end		
Chamfered bolt angle - - see Fig.7				0° 90° 180° 270°	
Voltage % duty rating					24v 100%

Ancillary Items	Order Code
Manual override key fig.8	P0200478
Door proving Contact set to SK6619 fig.9	P0200342



Fig. 8 Override key

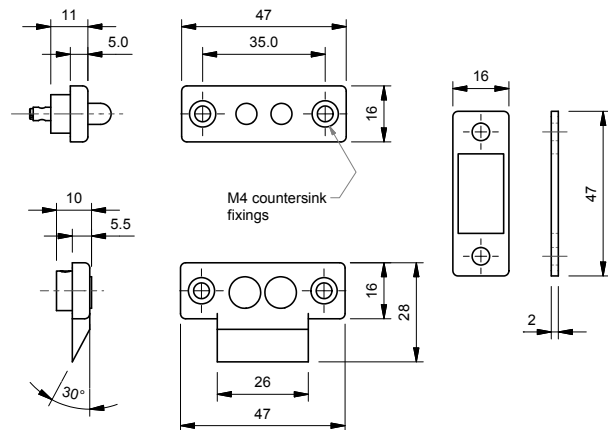

Fig.9 Door proving contact set