

D.C. Single-Acting Solenoid in explosion-protection Design

1

Product group

G T C E

- To DIN VDE 0580 and RL 94/9/EG (ATEX 95)
- Increasing magnetic force / stroke characteristic
- Size 050 in pull type
Sizes 100 in pull type and push type
Size 140 in push type
- Armature lining in maintenance-free bearings
High service life
- Coil winding corresponds to insulation classification F
- Electrical connection and protection class if mounted properly:
 - Size 50:
Protection class to DIN VDE 0470/EN 60529 - IP 54
Explosion protection Ex II 2G EEx em II T4
 - Size 100/140:
Protection class to DIN VDE 0470/EN 60529 - IP 54
Explosion protection Ex II 2G EEx em II T4/T5
- Flange mounting via three threaded bore holes, or with additional flange respectively
- Variations and special designs on request
- Application examples:
Chemical companies, refineries and fuelling facilities



Fig. 1: Type GTCE 100 AEM A01

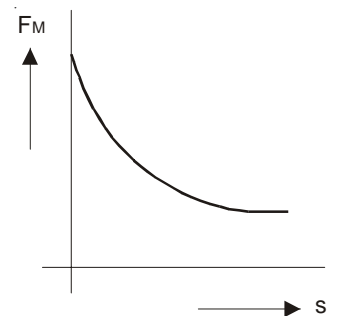

Fig. 2: Magnetic force / Stroke Characteristic



Technical Data

		G T C E ... A E M A 01			G T C E 100 A E M A 10			
		D.C. Types			A.C. Types (with integrated rectifier)			
		050	100	140				
Operating Mode		S1	S1	S1	S1			
Stroke s (mm)	Magnetic force F_M (N)							
	0	90	317	549	317			
	2	23	143	342	143			
	3	21	130	333	132			
	4	19	126	328	126			
	5	18	124	324	124			
	6	17	122	319	122			
	8	14	121	315	121			
	10	12	116	306	116			
	12		113	299	113			
	15		106	288	106			
	20		96	266	96			
	25		84	227	84			
	30		67	189	67			
	35			153				
	40			122				
Work rating A_N	(Ncm)	12	201	488	201			
Rated power P_{20}	(W)	14	52	87	51			
max. reference temperature	(°C)	40	40	40	40			
max. switching frequency S_h	(1/h)	15,000	5,700	3,400	5,700			
Closing time t_1	(ms)	128	400	625	400			
Opening time t_2	(ms)	101	230	410	230			
Inductance $L = \pi \times R$ ($\pi \times 10^{-3}$)	Time constant π Armature in start of stroke position (ms)	15	52	64	52			
	Armature in end of stroke position (ms)	18	45	85	45			
Armature weight m_A	(kg)	0.14	1.25	1.85	1.25			
Solenoid weight m_M	(kg)	1.14	7.04	17.33	7.04			
Circuit diagram								

The times listed in above table refer to rated voltage, max. stroke, weight load 70 % of rated magnetic force. They may decrease essentially with a higher load.

Rated voltage $\equiv 24$ V, on request the coil winding can be adjusted to a rated voltage of $\equiv 230$ V maximum or 230 V/50 - 60 Hz respectively.

The magnetic force values mentioned in the table refer to 90 % of the rated voltage and hot condition. There may be deviations with other rated voltages. Owing to natural dispersion, the magnetic-force-values may deviate by approx. ± 10 % from the values indicated in the tables.

Please make sure that the described devices are suitable for your application. Please find further details and definitions in our Technical Explanation or, respectively, in VDE 0580.

Hot condition is based on:

- a) mounting on heat-conducting base
- b) rated voltage $\equiv 24$ V or 230 V/50 - 60 Hz respectively (other voltages on request)
- c) operating mode S1 (100 % ED)
- d) reference temperature 40°C

- 1) The user has to ensure by the activation that with a rated voltage
 - to 30 V the disconnect-overvoltage of 480 V
 - to 60 V the disconnect-overvoltage of 800 V
 - to 110 V the disconnect-overvoltage of 1200 V
 - to 250 V the disconnect-overvoltage of 1600 V will not be exceeded.

Please also note the accompanying operating manual which will be delivered with each device. A declaration of the manufacturer is enclosed to the consignment once.

Dimensions sheet

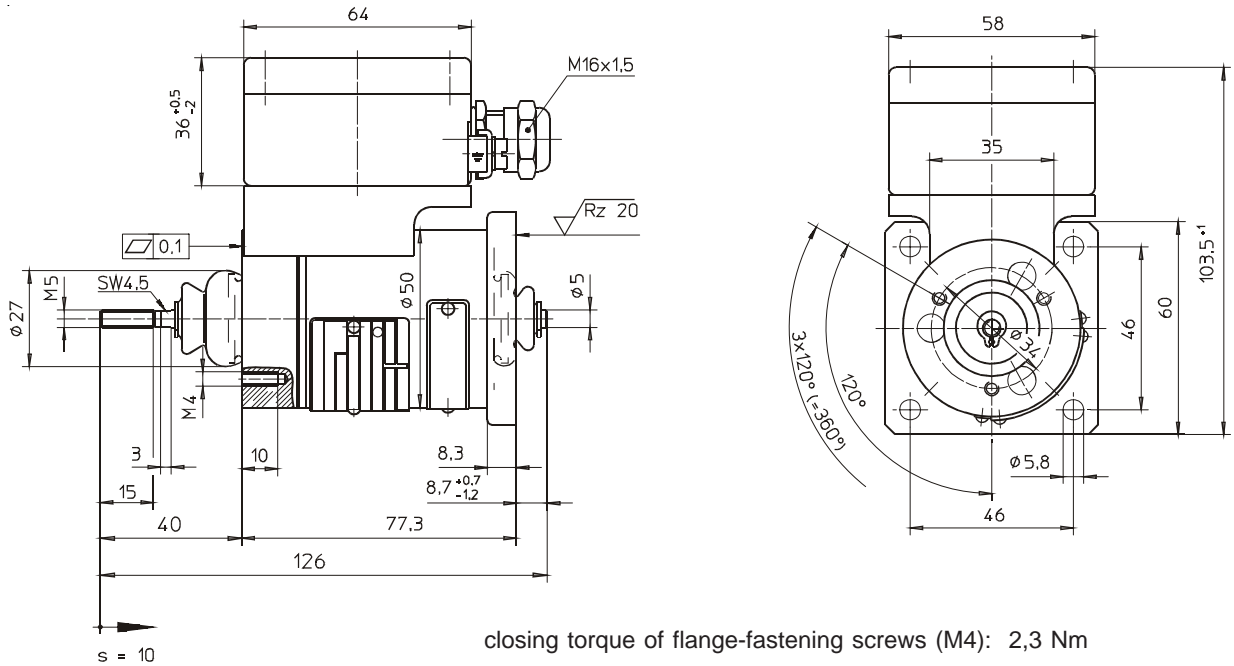

Fig. 3 Type GTCE 050 AEMA01

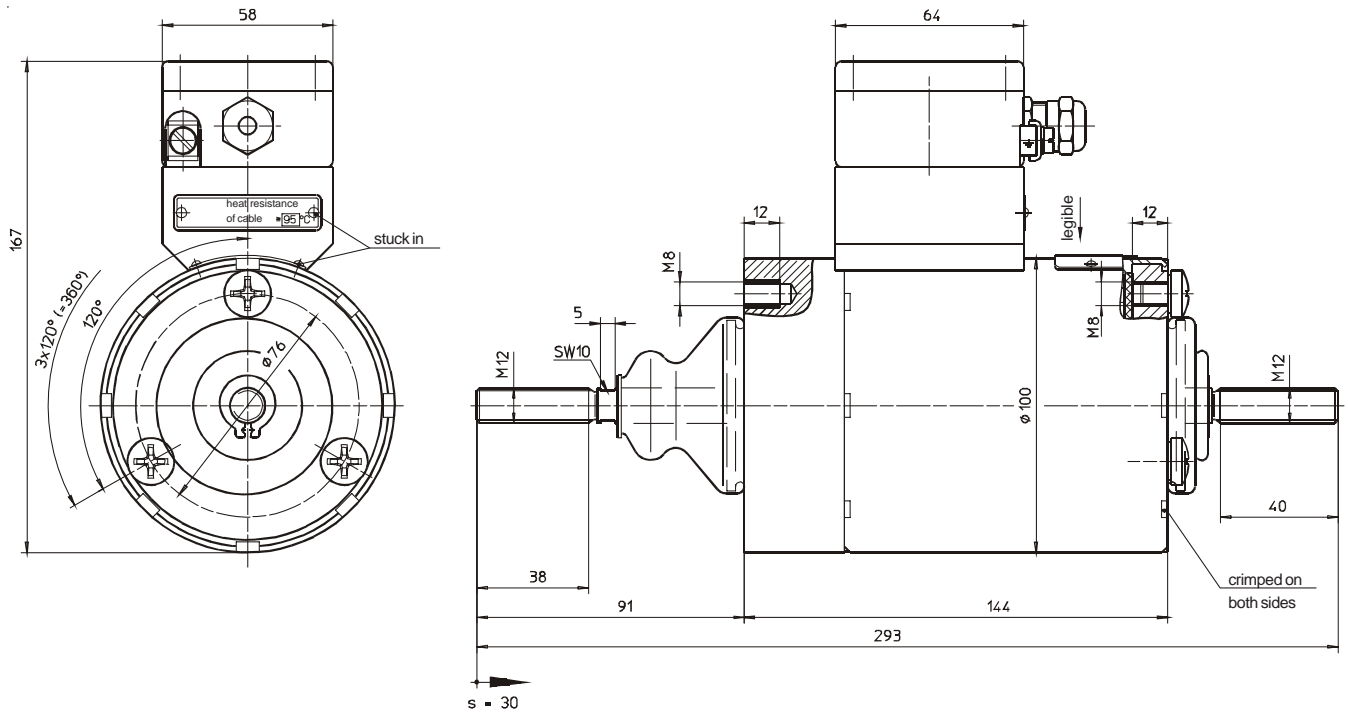

Fig. 4: Type GTC E 100 AEMA01 (DC) to Type GTC E 100 AEMA10 (AC)

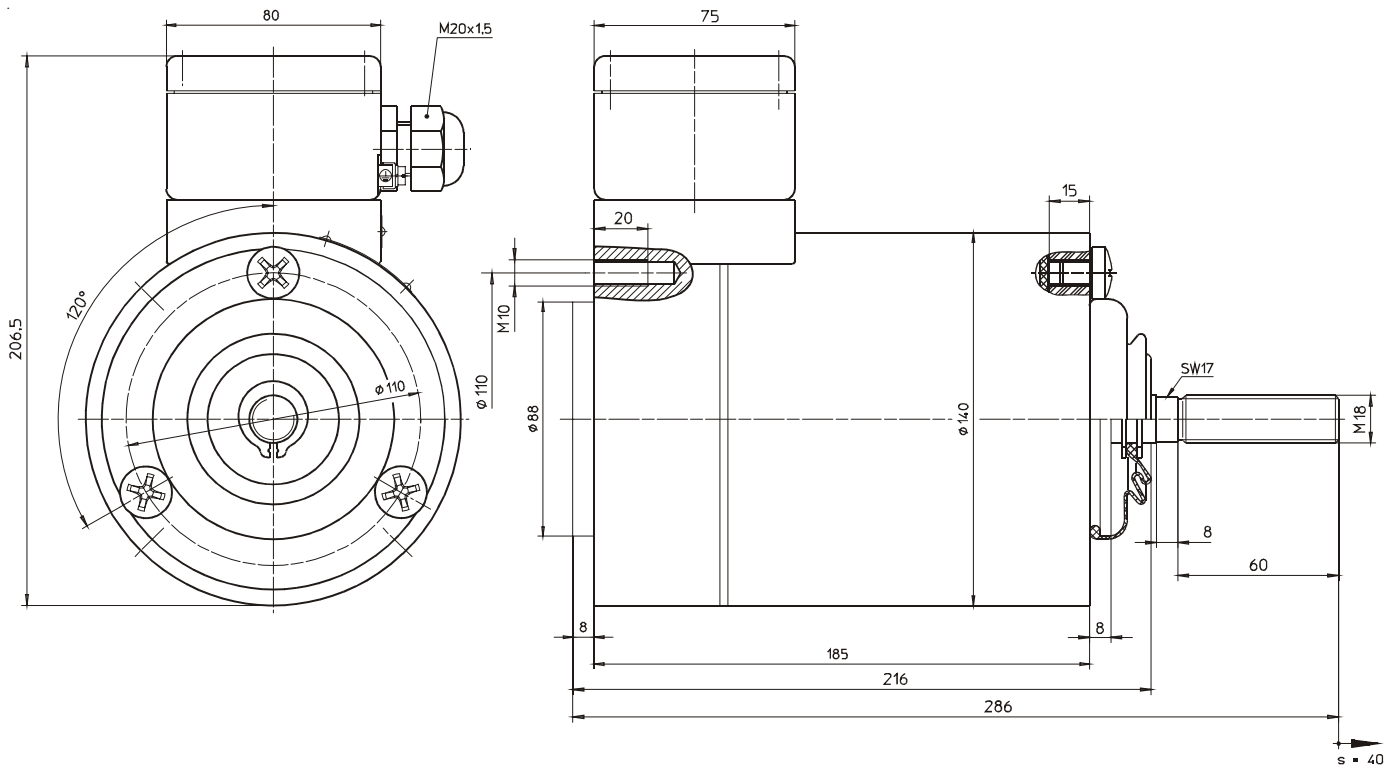
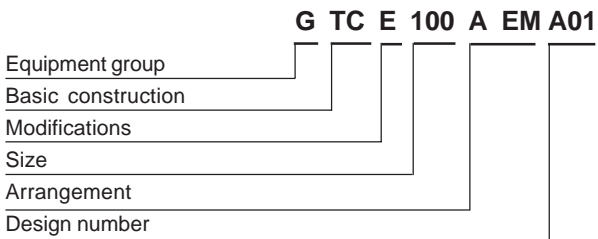

Fig. 5: Type GTCE 140 AEMA01

closing torque of flange-fastening screws (M10): 36 Nm

The solenoids shown are not ready-to-use devices in the sense of DIN VDE 0580. The general requirements and protective measures to be taken by the user, are included in DIN VDE 0580. The use of the shown devices in safety relevant applications need always the written agreement of MSM.

Type code



Order Example

Type	G T C E 100 A E M A 01
Voltage	== 24 V DC
Operating mode	S1 (100 %)

Specials

Special designs and modifications are available on request for which full application conditions should be specified in accordance withour Technical Explanations.