

Intrico

Meggitt Fuelling Products
Avery-Hardoll
Whittaker Controls

BOTTOM LOADING COUPLER F228



F228 Bottom loading coupler

The Whittaker four-inch bottom loading coupler is designed in accordance with API RP1004.

NOTES:

1. Modification A, K & N may be added to the basic F228 and all other modifications
2. Modification C may be used in conjunction with all other modifications
3. Modifications D, F, & G are separate modifications and cannot be combined with each other
4. See back page for dimension of basic style coupler

Features

- Push-on, pull-off, one-hand operation no rotation-no slots
- Fully interlocked - can't be opened unless locked and can't be removed unless closed
- Minimum disconnect spillage with dual seals within API specs
- Floating nose seal provides positive seal under operating conditions
- Dust protection sleeve seal
- Full flow four-inch design - 4.7 PSI pressure drop thru F228/F433 at 1000 gpm
- Lightweight design - 13.6 pounds
- Four-inch NTT flanged inlet standard, other options available as listed below
- Mates adapters made to API PR1004 (See catalog page on API adapters)
- Standard seals recommended for all commercial automotive and aircraft fuels, Viton seals available
- Whittaker four-inch swivels available as modifications
- Operating pressure - 120 PSI maximum, 350 PSI peak surge

For modifications see modification Page M228.

See the modification section of this catalog for various options to the part number listed above.

Contact your local Whittaker distributor or Whittaker directly for technical information beyond that listed in the technical section of this catalog.

MEGGITT

BOTTOM LOADING COUPLER

F228

F228 Dimensions

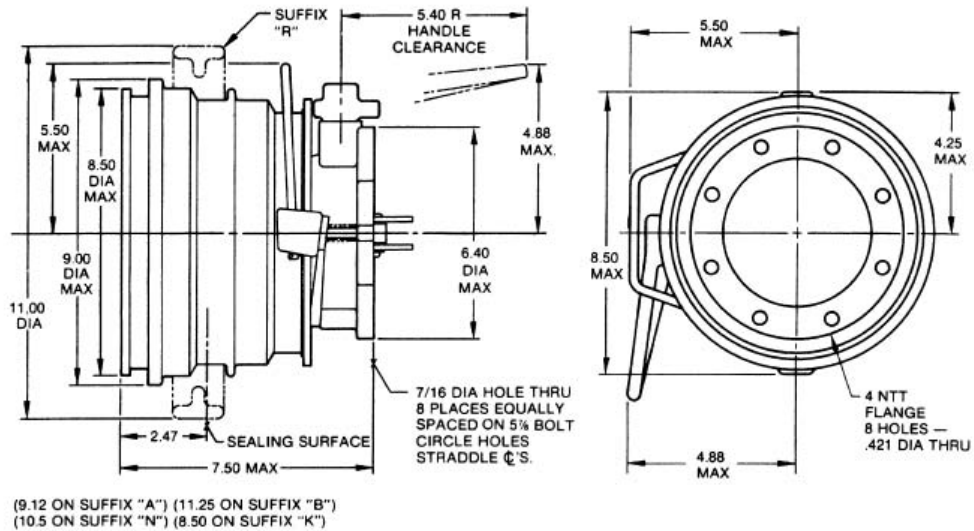

Avery-Hardoll
 Holland Way
 Blandford Forum
 Dorset DT11 7BJ
 UK

Tel: +44 (0) 1258 486600
 Fax: +44 (0) 1258 486601

www.meggittfuelling.com

Intrico Products Ltd
 Unit 5, Harrison's Farm Estate
 Inglewhite Road
 Goosnargh
 Preston
 PR3 2ED
 Tel : 01772 785295
 Fax : 01772 378646
sales@avery-hardoll.co.uk

