



**SP054**

**E and M**

**700 Series**

**Two Post Surface Mounted Lifts**

Capacity: 5,400kg (1,350kg per arm)



P  
A  
R  
T  
S  
  
B  
R  
E  
A  
K  
D  
O  
W  
N

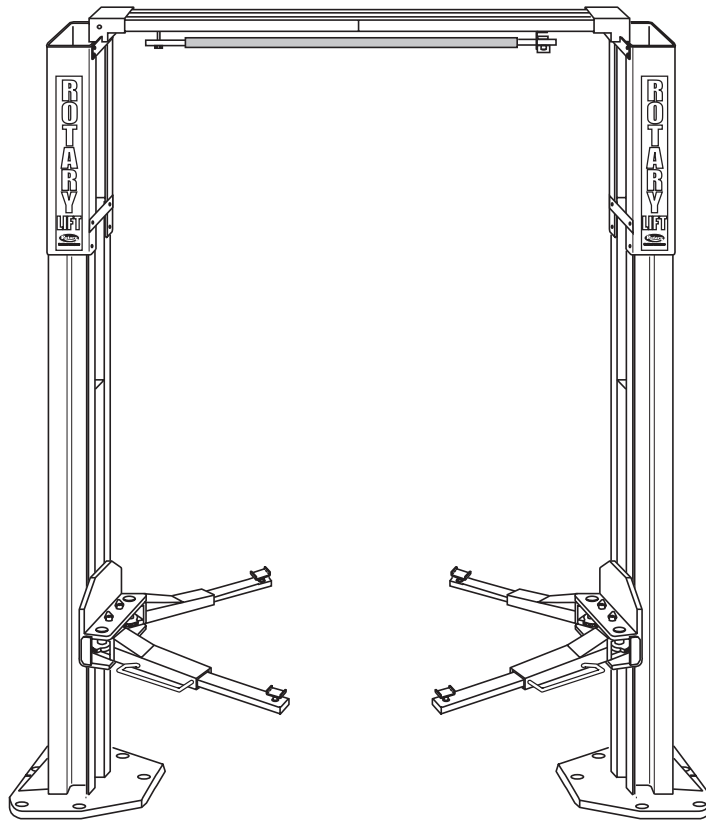

**IMPORTANT:** When ordering parts or requesting service always give exact model and power unit serial number. Model number is shown on nameplate attached to power unit column. Power unit serial number is located on side of power unit.

**OWNERS RECORD**  
Complete information  
at right and keep in  
a safe place.

Date Installed \_\_\_\_\_

Installed in Bay # \_\_\_\_\_

Power Unit Serial # \_\_\_\_\_

Power Unit Model # \_\_\_\_\_

Lift Serial # \_\_\_\_\_

Lift Model # \_\_\_\_\_

**NOTE:** For replacement parts -See your nearest Rotary Parts Distributor.

**PB2-32-32-1**

Rev. - 06/12/2008

# M Series Parts List

1.	L.H. Column	N754
2.	R.H. Column	N757
3.	Column Extension	
	Standard Height	N477
	EH-1 Model	N478
	EH-2 Model	N479
4.	Carriage Yoke	N826
5.	Power Unit (with control panel)	
	1Ø	P3458
	3Ø	P3395
6.	Stiffener Angle	N417-3
7.	71" Hydraulic Cylinder	N345
8.	Slider Block Shim	N115
9.	Power Unit Hose	FJ837
10.	5/16"-18NC x 1-1/2" HHCS	40271
11.	Number Not Used	N/A
12.	Number Not Used	N/A
13.	3/8"-16NC x 1" Flanged HHCS	40144
14.	3/8"-16NC Flanged Locknut	40664
15.	Adapter	FJ6214
16.	90mm Adapter Extension	FJ6171-1
17.	130mm Adapter Extension	FJ6171-2
18.	Adapter Rack	FJ6127
19.	3/8"-16NC x 3/4" Flanged HHCS	40124
20.	Bleeder Screw	N/A
21.	Carriage Bumper	FA950
22.	Arm Pin	N2154
23.	Approach Bumper (Door-18" Lg-2 Req'd)	FJ7391-1
24.	5/8"-11NC Nylon Insert Locknut	40743
25.	Cable End Bracket	N619
26.	Truarc #5304-75 Klipping for 3/4" Shaft	41411
27.	Sheave Assembly	N417-1
28.	Wheel Spotting Dish Kit	FF729-1
29.	Actuator Pin Handle	FJ7985-1
30.	Actuator Pin	N121-1
31.	Retaining Klipping	N119-3
32.	Arm Restraint Spring	FJ7656-2
33.	Arm Restraint Pawl	N2121
34.	Spring Pin, 1/4" dia. x 1-1/2" Lg. (stainless)	14427
35.	1/4"-20NC Nylon Insert Locknut	40642
36.	3/8"-16NC x 1-1/2" HHCS Grade 8	-----
37.	3/8" Spring Washers	40818
38.	Arm Restraint Gear	N2122
39.	Slider Block	FJ7360
40.	20mm Concrete Anchor	W140210
41.	Machinery Bushing	41388
42.	1/4"-20NC x 2-3/4" HHCS	40114
43.	Overhead Mounting Bracket	N440
44.	Left Toe Guard	N137-1
45.	Right Toe Guard	N138-1
46.	Switch Bar Assembly	N415
47.	Cable Guide	N618
48.	R.H. Overhead Weldment (Inner)	N481-1
49.	L.H. Overhead Weldment (Outer)	N480-1
50.	Tie Bar Weldment	N1162-1
51.	Overhead Hose	
	Standard Height Model	FJ843
	EH-1 Model	FJ844
	EH-2 Model	FJ845
52.	Equalizer Cable	
	Standard Height Model	N387
	EH-1 Model	N388
	EH-2 Model	N389
53.	5/16"-18NC x 3/8" PHMS	40227
54.	Arm Guard Spacer	N283-7
55.	5/16"-18NC x 2-1/2" HHCS	40246
56.	5/16" External Tooth Lock Washer	40854
57.	Sheave Shaft	FJ7444-8
58.	5/16"-18NC x 3/4" HHCS	40252
59.	1/4"-20NC x 1" HHCS Grade 5	40108
60.	Sheave Cover	N119-1
61.	1/4"-20NC x 3/8" PHMS	40063

62.	5/16"-18NC Nut	40670
63.	Hose Clip	N383
64.	#12 Type B x 1/2" SI. HWHTS	40057
65.	Branch Tee	FJ7668
66.	Low Profile Adapter	FJ6202
67.	5/16" SAE Flat Washer	40856
68.	1/4"-20NC Flanged Locknut	40641
69.	3/4" Spacer	FJ7871
70.	1/4"-20NC Hex Nut	40627
71.	1/4" External Tooth Lock Washer	40779
72.	Limit Switch Assembly	N412
73.	1/4"-20NC x 3/4" HHCS Grade 5	40098
74.	Limit Switch	N411-1
75.	Wire Grommet	FA7180-31
76.	5/16" Split Lock Washer	40850
77.	Arm Guard (710 and 7A0 Series)	
	Right Front	N283-6
	Left Front and Both Rears	N253-3
78.	Arm Assembly (710 Series)	N2292
79.	Arm Assembly (7G0 Series)	N2264
80.	Number Not Used	N/A
81.	Arm Assembly (7A0 Series)	N2272
82.	Arm Guard (7G0 Series)	
	Right Front	N2264-14
	Left Front and Both Rears	N2264-13
83.	Left Front and Both Rears	N2264-13
84.	Front Shim	FJ659-3
85.	Horse Shoe Shim	FJ716-6
86.	Full Size Baseplate Shim Kit	FA5129
87.	Control Panel	
	1Ø	FA7928
	3Ø	FA7927
88.	3/8"-16NC x 1/2" Flanged HHCS	40196
89.	3/8"-16NC x 3/4" Carriage Bolt	N/A
90.	Adapter Plate	FA7926
91.	5/16"-18NC x 1/2" Socket Flat Head MS	40375
92.	#8-32NC x 3/8" Hex SHCS	40087
93.	Strain Relief	P1164-4

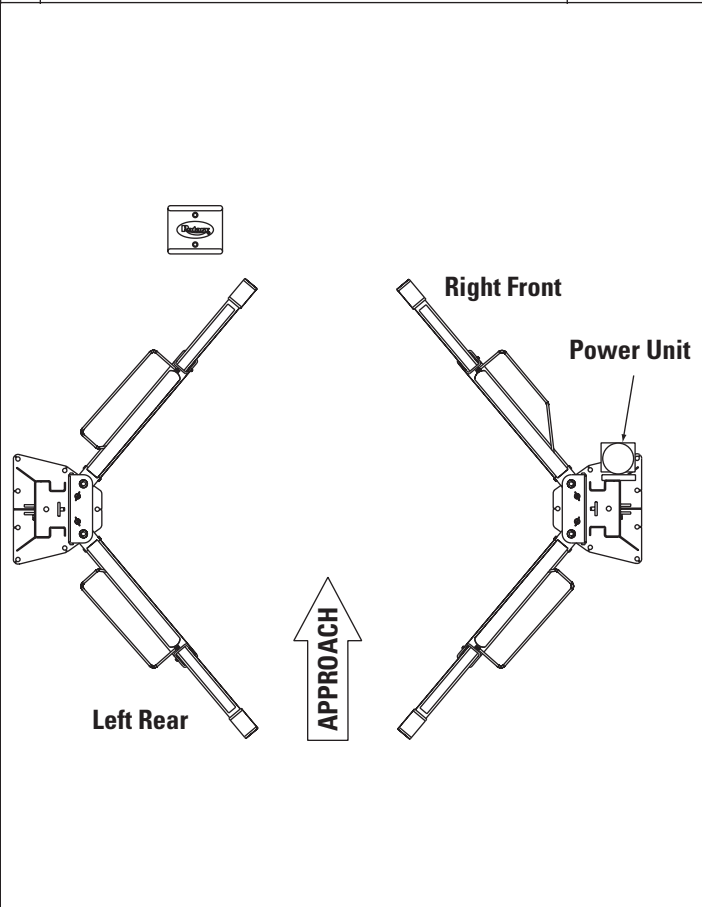

# M Series Parts List

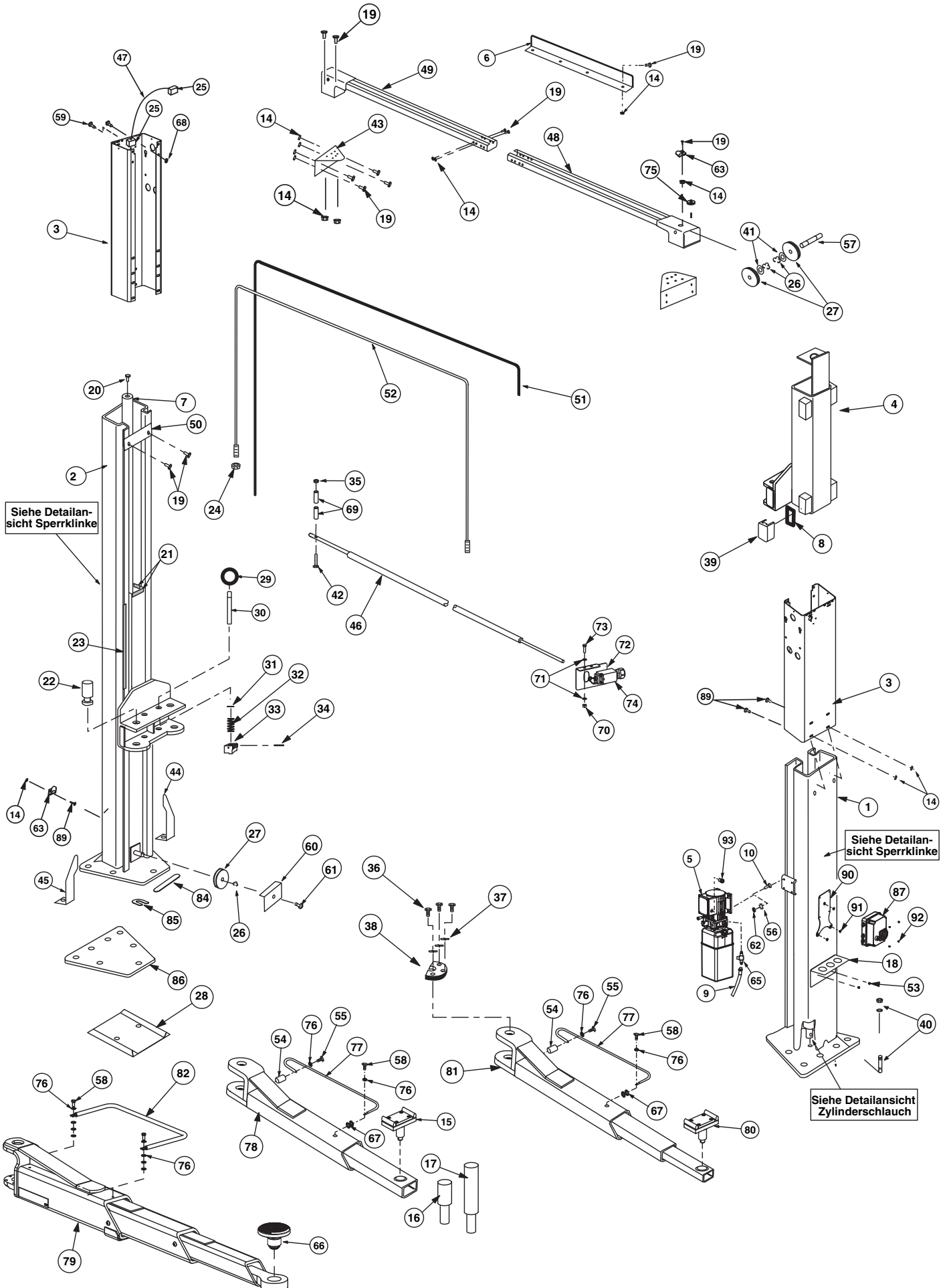

# M Series Parts List

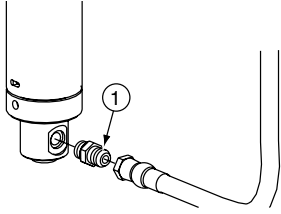

## CYLINDER ADAPTER/HOSE DETAIL PARTS LIST

Item	Description	Part No.
1	Straight Adapter	FJ7352-3

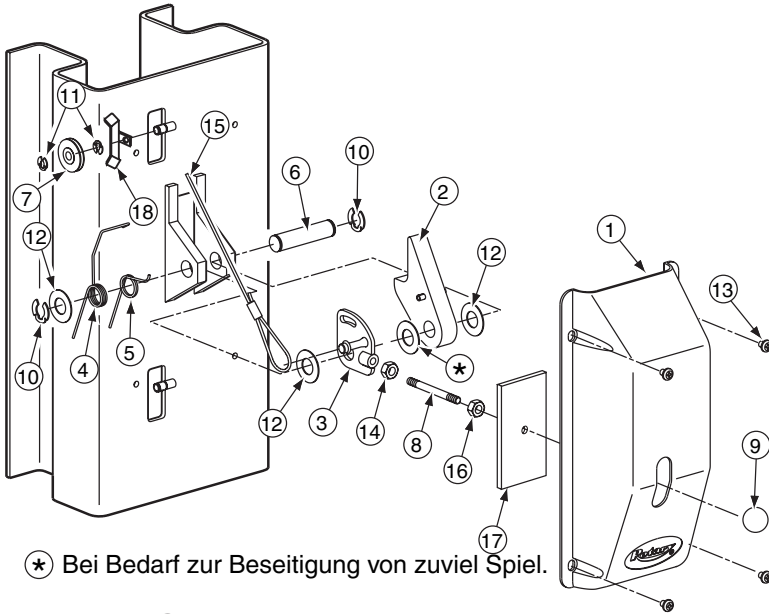

★ Bei Bedarf zur Beseitigung von zuviel Spiel.

## RIGHT COLUMN

## LOCKING LATCH DETAIL PARTS LIST

Item	Description	Part No.
1	Control Side Cover	FJ7452
2	Locking Latch Dog	N615
3	Control Plate	FJ7594-2
4	Spring	FJ7566-10
5	Spring	FJ7382-9
6	Latch Shaft	FJ7382-34
7	Locking Latch Sheave	FJ7322
8	Handle	FJ7382-18
9	Ball Handle	FC134-91
10	Truarc Klipring #5304-75 (for 3/4" Shaft)	41411
11	Truarc Klipring #5304-37 (for 3/8" Shaft)	41410
12	1-1/2" O.D. x 3/4" I.D. x .045" Mach. Bush	41388
13	5/16"-18NC x 3/8" Lg. BHCS (Allen Socket)	N/A
14	3/8" - 16NC Hex Jam Nut	40658
15	Locking Latch Cable	FJ7600
16	1/2"-13NC Jam Nut (Spacer)	40700
17	Slot Cover	N617
18	Latch Sheave Cover	N64

## LEFT COLUMN

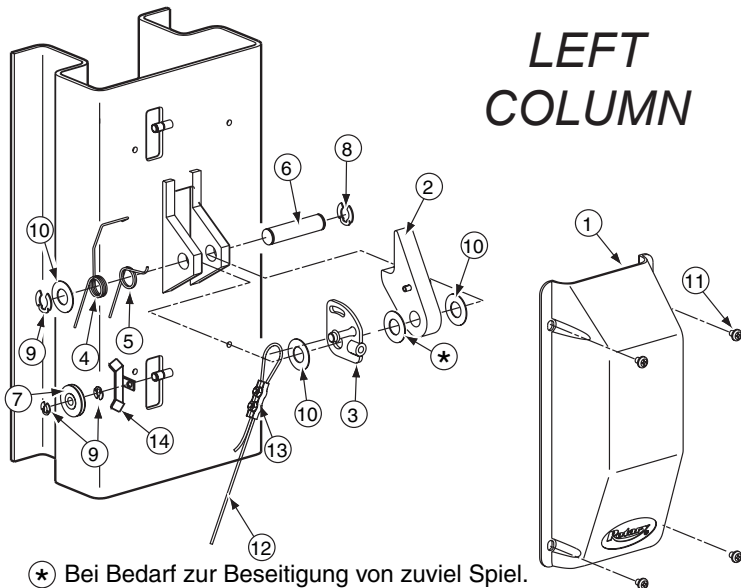

★ Bei Bedarf zur Beseitigung von zuviel Spiel.

## LOCKING LATCH DETAIL PARTS LIST

Item	Description	Part No.
1	Latch Cover	FJ7451
2	Locking Latch Dog	N615
3	Control Plate	FJ7594-2
4	Spring	FJ7566-10
5	Spring	FJ7382-9
6	Latch Shaft	FJ7382-34
7	Locking Latch Sheave	FJ7322
8	Truarc Klipring #5304-75 (for 3/4" Shaft)	41411
9	Truarc Klipring #5304-37 (for 3/8" Shaft)	41410
10	1-1/2" O.D. x 3/4" I.D. x .045" Mach. Bush	41388
11	5/16"-18NC x 3/8" Lg. BHCS (Allen Socket)	N/A
12	Locking Latch Cable EH-4 for SPO40	FJ7595-1 FJ7600
13	Latch Cable Clamp	N63-1
14	Latch Sheave Cover	N64

# E & i Series Parts List

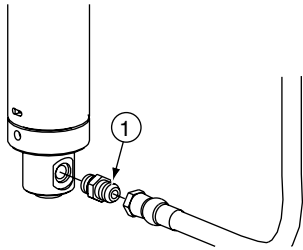

CYLINDER HOSE ADAPTER DETAIL		
ITEM	DESCRIPTION	PART
1	Straight Adapter	FJ7352-3

## SOLENOID / LOCKING LATCH ASSEMBLY

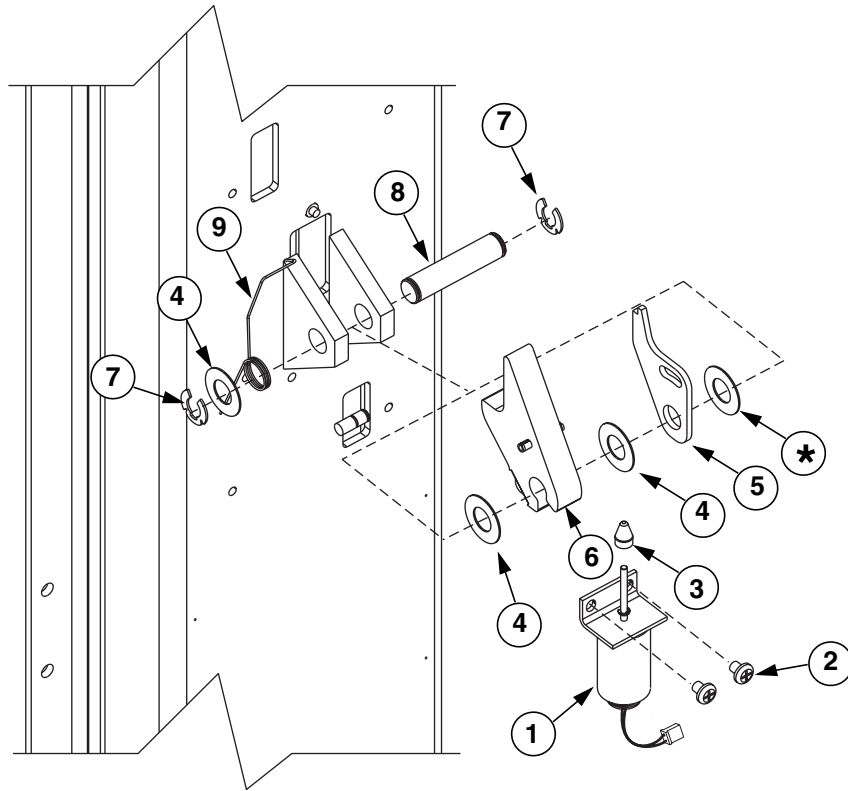

LOCKING LATCH DETAIL PARTS LIST		
ITEM	DESCRIPTION	PART
1	Solenoid	FA7434-6
2	5/16" - 3/8" PHMS	40227 2 REQ'D
3	Slider	N613-1
4	1-1/2" O.D. x 3/4" I.D. x .045 Mach. Bush.	41388
5	Latch Control Plate	N613-3
6	Locking Latch	N615
7	Truarc Klipring #5304-75 for 3/4" Shaft	41411
8	Latch Shaft	FJ7382-34
9	Latch Spring	N613-2

# E Series Parts List

1	L.H. Column Weldment	N754
2	R.H. Column Weldment	N754
3	Column Extension	
	Power Unit Side	
	Standard Height	N490
	EH-1	N491
	EH-2	N492
	Non-Power Unit Side	
	Standard Height	N477
	EH-1	N478
	EH-2	N479
4	Carriage Yoke Weldment	N826
5	Arm Pin	N2154
6	1/4"-20NC Locknut	41250
7	Hydraulic Cylinder	N347
8	Power Unit	*P1373/P3373
9	Power Unit Hose	N392
10	5/16"-18NC x 1-1/2" Bolt (Full Thread)	40271
11	Vibration Pad	P1164-3
12	5/16"-18NC Hex Nut	40670
13	Actuator Pin Handle	FJ7985-1
14	Actuator Pin	N121-1
15	Retaining Pin	N119-3
16	Arm Restraint Spring	FJ7656-2
17	Bleeder Screw (Specify Manufacturer)	N/A
18	100mm Carriage Bumper (4 per lift)	FJ7391-2
	32mm Carriage Bumper (2 per lift)	FJ7391-5
19	120T Gear Block	N2121
20	457mm Approach Bumper	FA927-2
21	5/8"-11NC Nylon Insert Lock Nut	40743
22	Truarc #5304-75 Klipping for 3/4" Shaft	41411
23	Sheave Assembly	N417-1
24	Shim Kit	FA5129
25	Sheave Cover	N119-1
26	1/4"-20NC x 3/8" Lg. PHMS Plated	40063
27	Slider block	FJ7360
28	20mm Concrete Anchor	W140210
29	1-1/2" O.D. x .760-.770" I.D. x .045" Bushing	41388
30	Wiring Chase	FA929
	Rib Gasket	FA7211-22
31	#8-32 Type B x 5/8" Lg. PHTS	41457
32	Web Cover	FA949
33	19mm Spacer	FJ7871
34	Spotting Wheel Dish Kit	FF729
35	Restraint Gear	N2122
36	3/8"-16 NC x 3/4" Long Flanged HHCS	40124
37	Overhead Hose	
	Standard Height	N393
	EH-1	N394
	EH-2	N395
38	Equalizer Cables	
	Standard Height	N387
	EH-1	N388
	EH-2	N389
39	Horse Shoe Shim	FJ716-6
40	Front Shim	FJ659-3
41	Limit Switch	N411-1
42	3/8"-16NC Flanged Locknut	40664
43	Sheave Shaft	FJ7444-8
44	Slider Block Shim	N115
45	Male Extension With ORing	N332
46	Hose Clip	N383
47	1/4"-20NC 2-3/4" Hex Head Bolt	40114
48	Rack for Adapter Extensions	FJ6145
49	Female Swivel Tee	N331
50	Switch Bar Assembly	N467
51	3/8"-16NC x 1/2" Flanged HHCS	40122
52	1/4"-20NC x 3/4" HHCS Grade 5	40104
53	1/4" External Tooth Lock Washer	40779
54	1/4"-20NC Hex Nut	40627
55	Limit Switch Assembly	N412
56	Adapter Assembly	FJ6214

57	Spring Pin-1/4" dia. x 1-1/2" Lg. (Stainless)	14427
58	Hose Grommet	FA7180-32
59	3/8"-16NC x 1-1/2" HHCS Grade 8	-----
60	3/8" Spring Washers	40818
61	Number Not Used	N/A
62	Number Not Used	N/A
63	Arm Assembly (710 Series)	N2292
64	Arm Assembly (7G0 Series)	N2264
65	Arm Assembly (7A0 Series)	N2272
66	Arm Guard	
	Right Front	N2264-14
	Left Front and Both Rears	N2264-13
67	Number Not Used	N/A
68	Master Control Panel	
	3Ø/LCD	FA7305
	3Ø/NON-LCD	FA7304
	Edge Gasket	FA7211-23
	Slave Control Panel	
	3Ø	FA7301
	Edge Gasket	FA7211-23
69	Air Tool Holder Weldment	FA5162
70	L.H. Overhead Weldment (Outer)	N480-1
71	R.H. Overhead Weldment (Inner)	N481-1
72	Junction Box	N/A
73	Slave Control Cable Extension	
	Standard Height	FA7180-43
	EH-1	FA7180-55
	EH-2	FA7180-44
74	E-Stop Cables	
	EH-1	FA7212-7
	EH-2	FA7212-2
75	5/16"-18NC x 3/8" PHMS (for Control Panels/Tool Holders)	40227
76	Wire Grommet	FA7180-31
77	Mounting Bracket	N440
78	Tie Bar Weldment	N1162-1
79	Number Not Used	N/A
80	3/8"-16NC x 3/4" Carriage Bolts	N/A
81	Overhead Stiffener Angle	N417-3
82	90mm Adapter Extension	FJ6171-1
83	130mm Adapter Extension	FJ6171-2
84	Rack for Adapter Extensions	FJ6127
85	Low Profile Adapter Assembly	FJ6202
86	Slave Control Panel	FA7520
87	Master Harness	FA7612
88	Motor Cable 3Ø	FA7953
89	Power Harness	FA7947
90	Power Harness Extension	
	EH0	FA7804
	EH1	FA7810
	EH2	FA7811
91	Slave Harness	FA7703
92	Arm Guard Spacer	N283-7
93	5/16" Split Lock Washer	40850
94	5/16"-18NC x 2-1/2" HHCS	40246
95	Arm Guard	
	Right Front	N283-6
	Left Front And Rear	N253-3
96	5/16"-18NC x 3/4" HHCS	40252
97	5/16" Flat Washer	40856
98	Web Cover	FA948

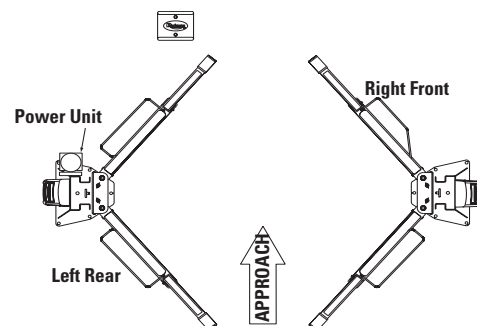



DATE	REV.	CHANGE MADE
6-12-2008	-	New Model Issue

World Headquarters:  
**Rotary Lift**  
A  **DOVER** COMPANY  
2700 Lanier Drive  
Madison, Indiana USA  
Phone: 1.800.445.5438  
Phone: 1.812.273.1622  
Fax: 1.800.578.5438  
Fax: 1.812.273.6502  
userlink@rotarylift.com  
www.rotarylift.com

Germany:  
(European Headquarters)  
**BlitzRotary GmbH**  
Bräunlingen  
Phone: +49.0771.9233.0  
Fax: +49.0771.9233.99  
europe@rotarylift.com

Canada:  
(Regional Sales Office)  
**Rotary Lift Canada**  
Mississauga, Ontario  
Phone: 888.256.4195  
Phone: 905.812.9920  
Fax: 905.812.9719  
canada@rotarylift.com

United Kingdom:  
(Regional Sales Office)  
**Rotary Lift (UK) LTD.**  
Halstead, Essex  
Phone: +44.178.747.7711  
Fax: +44.178.747.7720  
sales@rotarylift.idps.co.uk

Austral-Asia:  
(Regional Sales Office)  
**Rotary Lift Austral/Asia**  
Petaling Jaya, Malaysia  
Phone: +60.3.7660.0285  
Fax: +60.3.7660.0289  
rlim@rotarylift.com

