



43 Dering Crescent
Leigh-On-Sea
Essex
SS9 5RD

Tel: 0845 519 0560
Fax: 0845 519 0570
e: sales@rocburn-fire.co.uk
w: www.window-openers.com

Highline Window Control Systems

by rocburn limited

» Manual

» Electric

» Smoke

» Contents

Manual

Manual Systems	4
T100 & T150 Chain Openers	6
T250 & T260 Operators	8
T200, T210 & T300 Operator	9
T125, T175, T190 & SJ138600 Openers	10
Screwjacks & Poles	11
Accessories	12
Technical Data	14

Electric

Electric Systems	16
ACK4 Actuator	18
SuperMaster Actuator	20
XP Actuator	22
TwinMaster Actuator	23
C240 Actuator	24
MPD Actuator	25
Max Actuator	26
Rack Actuator	27
Dual Rack Actuator	28
Double Rack Actuator	29
SL60 Actuator	30
PL6 Actuator	31
ST70 Conservatory Panel	32
RRT Radio Control Unit	33
Switches	34
PS24 Transformer	34
TP Tandem Panels	34
Technical Data	35

Smoke

Smoke Control Systems	36
VCS-1 Control Panel	38
SVCS-1 Control Panel	39
Purpose Made Panels	40
Smoke Sensors	42
Break Glass Switch	42
Fireman's Override Switch	42
Fireman's Key Switch	43
Rain Sensor	43
Wind sensor	43
Thermostat	43

A comprehensive range of manual and electrically operated systems to provide natural ventilation or automated smoke control to a variety of window styles in timber, steel, aluminium or PVCu.

The manual system is used extensively in schools, libraries and other public buildings to control high level or difficult access windows.

The system can be used on most styles of windows and materials to operate individual or multiple sets of windows from a single operator. The connecting conduit can be bent around pillars, mullions and other obstacles in its path.

There is also a range of screwjack openers and winding poles to operate conservatory roof vents.

Electric window controls for single, group or zoned operation from manually operated switches or automated controls panels linked to sensors for everyday ventilation or smoke control requirements.

Numerous types of 24V dc and 230V ac actuators are available to operate most types of windows, louvres, roof lights and domes.

Manual Window Control Systems

For single or group operation of high level windows. The chain opener can be fitted to most styles of aluminium, timber, or steel windows using the appropriate fixing brackets.

Controlled from a wall mounted operator connected via lengths of conduit and inner cable to the chain opener on the window. When the handle of the operator is turned the inner cable is driven forwards or backwards inside the conduit. The moving cable engages the cog wheel of the opener, driving the chain out to open the window.

Depending on height limitations, vents can be opened 250mm or 380mm, with suitable openers.

A very flexible system, as the conduit can be bent to go around pillars and other obstacles, using the special bending tool and fixed to the wall or framework with saddle brackets.

To allow for the forwards and backwards movement of the inner cable, a length of "spent travel" conduit, must be fitted at either end of the control path i.e. past the last chain opener and below the operator (except the T250 & T260 operators which have an integral "spent travel" tube)





» T100

The most popular type of window opener with 250mm travel. Can be used on most window styles and materials with the appropriate fixing brackets (see page 7).

The T100 can control individual or multiple sets of windows from a single operator (see pages 8, 9)

» T150

Similar to the T100 but with 380mm travel. The T150 cannot be used with the T250 operator.

» Standard Colours

- White (RAL 9010)
- Black (RAL 9005)
- Grey (RAL 9006)



T100 Vent Bracket



T100 Manual Operation

» Fitting Notes

T100

- For the full 250mm travel the vent must be 500mm high.

T150

- For the full 380mm travel the vent must be 900mm high.
- Travel on chain openers fitted to shallower windows must be restricted to 30% of vent height using T700 spring stops or T720 square nuts to shorten cable travel. All bottom-hung open-in applications require a minimum of 50mm head clearance.





PLEASE NOTE: For safety reasons we recommend fitting side support stays to all bottom-hung, open-in windows.

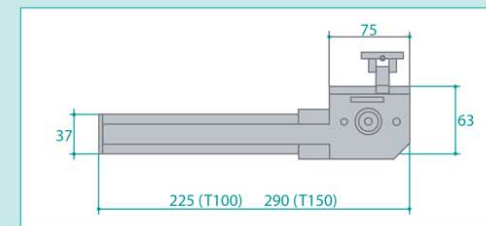

T100 colour variations

» Accessories & Tools

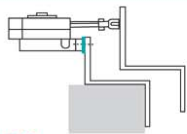
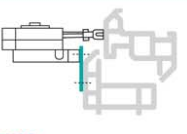
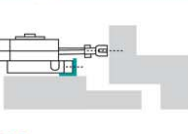
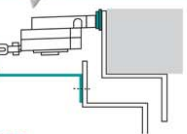

T740 Narrow Fixing Plate	T750 Wide Fixing Plate	T760 Angled Fixing Plate	T850 Bottom-Hung Fixing Kit
For surface fixing the chain opener to aluminium windows. Available in white, black or grey.	For surface fixing chain opener to PVCu windows. Available in white, black or grey.	For surface fixing chain opener to timber window sills. Available in white, black or grey.	Set of frame and vent brackets for fitting chain openers to bottom hung, open in windows. Available in white, black or grey.
			
			
T740	T750	T760	T850

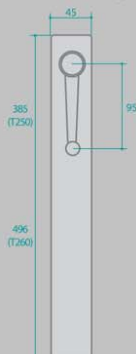

» T250

The standard or "Midi" type operator with long metal case enclosing the "spent travel" conduit and cable. Supplied complete with handle.

Please Note: The T250 cannot be used with the T150 chain opener – Use the longer T260 operator.

» T260

Similar to T250 but with longer body to use with the T150 chain opener.

» Standard Colours

White (RAL 9010)

Black (RAL 9005)

Grey (RAL 9006)



» T200

Heavy duty, metal cased operator designed for multiple window operation beyond the capability of the standard T250 and T300 operators.

- Supplied complete with handle.
- Recommended for use with the SJ138600 screwjack opener.
- Available in white or black.

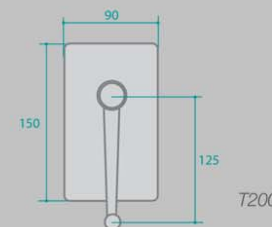

» T210

Budget priced heavy duty, metal cased operator. Ideal for multiple window operation beyond the capability of the standard T250 and T300 operators.

- Supplied complete with handle.
- Available in white, black or grey

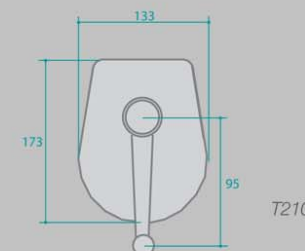

» T300

Small, metal cased operator for single or light multiple window control. Spent travel conduit will be exposed below the operator.

- Supplied complete with handle.
- Available in white, black or grey

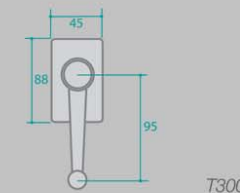

Openers – T125 / T175 / T190 / SJ138600

Screwjacks & Poles – W3030 / W3041

» T125, T126, T127

Manual chain operator for low level top hung windows with T126 handle or lightweight roof vents with T127 eyelet and W3041 winding pole (see page 11). Available in White, Black or Grey finishes.

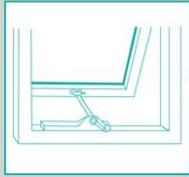

» T175

Use with the T250 or T300 operator to open/close bottom-hung, open-in windows, fitted with butt hinges. Minimum head clearance 25mm. Available in White, Black or Grey finishes.

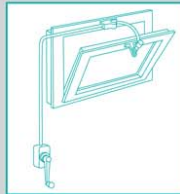

Please Note: For safety reasons we recommend fitting side support stays to all bottom-hung open-in windows.

» T190

Stainless steel telescopic fork drive to use with suitable operator to control banks of pivoting louvre blades. Maximum travel 250mm.

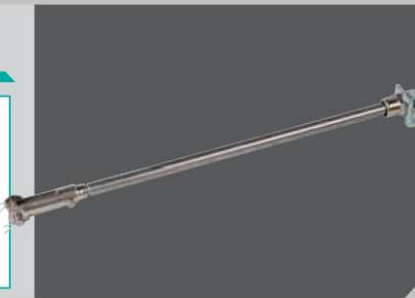
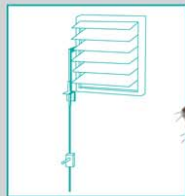

» SJ138600

Sill mounted screwjack to use with T200 or T210 operators to control roof vents. Available in white finish only.

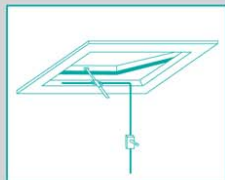

» W3030

Telescopic 300mm screwjack opener. Available in polished lacquered brass or bright chrome finish.

» W3041

Chrome or brass finished winding poles with wooden handles. Available in 1.7m, 2.2m & 2.8m lengths.



W3041 – Brass



W3030 – Chrome

» T270 Large Grip handle

Replacement large grip handle to suit all operators except T200. Available in white, black or grey.



» T275 Spare handle

Replacement handle to suit all operators except T200. Available in white, black or grey.



» T350 Rotary Junction Box

Used to connect satellite drive system to main control. Available in white, black or grey.



» T400 Conduit

Plastic covered metal tube with nylon inner liner. Used to connect operator to chain opener. Supplied in 3 metre lengths. Available in white, black or grey.



» T410, T411 Square Conduit

Mill finished aluminium spent travel to use with the T720 brass nut when both drives of the T250 (T410) or T260 (T411) operator are used.



» T420 End Plug

Plastic moulded plug to seal the open end of the conduit. Available in white, black or grey.



» T450 Inner Cable

Helical steel cable which fits inside the conduit to drive the gearbox of the operator, chain opener or screwjack.



» T600 Saddle Bracket

Frame Fix – Moulded plastic saddle bracket to fit conduit to window frame. Available in white, black or grey.



» T650 Saddle Bracket

Wall Fix – Moulded plastic saddle bracket to fit conduit to wall. Available in white, black or grey.



» T700 Spring Stop

Helical spring stop that can be threaded onto the end of the cable to restrict the travel of the chain opener/window opening.



» T720 Square Nut

Brass nut used in conjunction with T410 / T411 square conduit when both ports of T250 or T260 operator are used.



» T740 Narrow Fixing Plate

For surface fixing the chain opener to aluminium windows. Available in white, black or grey.

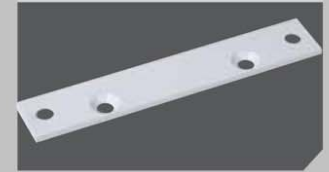

» T750 Wide Fixing Plate

For surface fixing chain opener to PVCu windows. Available in white, black and grey.

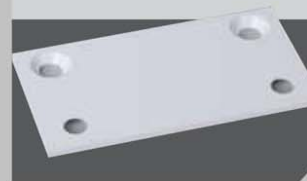

» T760 Angled Fixing Plate

For surface fixing chain opener to timber window sills. Available in white, black or grey.



» T800, T800M Conduit Connector

Moulded plastic (T800) or Metal (T800M) collar and sleeve used to connect lengths of conduit. Available in white, black or grey.



» T850 Bottom Hung Fixing Kit

Set of frame and vent brackets for fitting chain openers to bottom-hung, open-in windows. Available in white, black or grey.

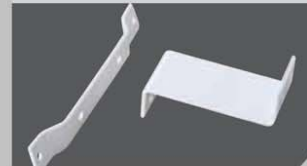

» T900 Conduit Tool

Tool used to form groove in the end of the conduit, enabling it to be located securely in the collar of the operator or chain opener.



» T950 Bending Tool

Curved metal tool used to bend the conduit to the correct radius.



» Manual Technical Data

Minimum window height for full 250mm travel of T100 = 500mm

Minimum window height for full 380mm travel of T150 = 900mm

Travel on chain openers fitted to a window less than recommended must be restricted to 30% of the vent height using the T700 spring stops or T720 square nuts to shorten the cable run. Use only T200, T210, T260 or T300 operator with the T150 (380mm) chain opener.

For safety reasons we recommend fitting side support stays to all bottom-hung, open-in windows. For bottom-hung applications you must fit the T850 fixing kit (sold separately see page 13).

» Maximum Control Run

Operator

T200 – 30 metres

T210 – 30 metres

T250/260 – 18 metres

T300 – 18 metres

» "Spent Travel" Conduit

To allow for the forward/backward movement of the inner cable a length of "spent travel" conduit must be fitted at either end of the control path i.e. past the last chain/screwjack and below the operator (except the T250 & T260 operators which have an integral "spent travel" tube).

Type of Operator	Spent Travel Conduit
138600 Screwjack	2.5m (for full 380mm travel)
T100 Chain Opener	0.3m
T150 Chain Opener	0.45m

» Number of chain openers per vent

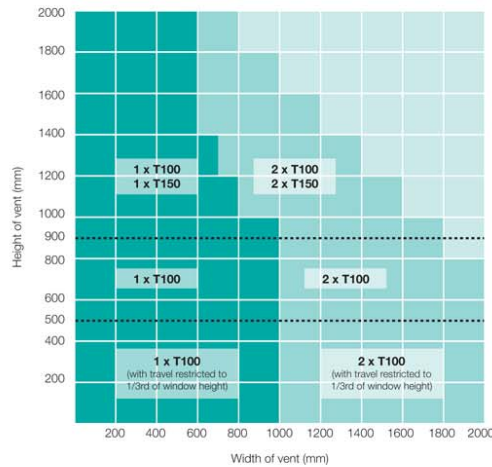

» Type of operator

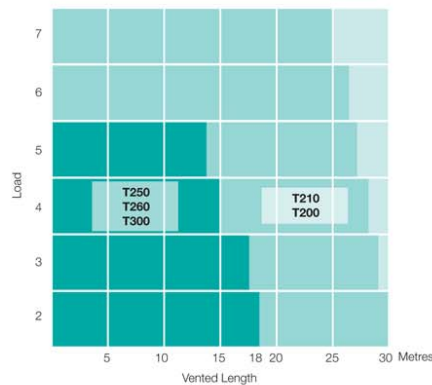

LOAD = No. of chain openers + No. of bends in conduit

The above figures are based on a single bend in the conduit path. For each additional bend deduct 1 metre from the Vented Length total.

The figures used in these charts are based on windows with 4mm double glazed units fitted to butt hinges or free pivots, not friction stays. Please refer to our sales or technical department for advice if friction stays are fitted.



Single, group or zoned operated window control systems. From manually operated switches to automatic control panels, there is something for every type of natural ventilation or smoke control requirement.

A wide variety of 24V dc and 230V ac actuators to operate top, side, pivot and bottom-hung windows, louvres, roof vents and domes.



» Technical Specification

Voltage	24V dc	230V ac
Stroke	100-400mm	100-400mm
Thrust Force	300N	300N
Absorbed Current	2.1A	0.32A
Speed	18mm/s	28mm/s
Protection Class	IP55	IP55
Wiring	2 Core	3 Core
Colours Available	White/Black/Silver	White/Black/Silver
Limit Stop	Electronic	Electronic
Safety Stop	Electronic	Electronic

» ACK4

» Product Summary

- Chain-type actuator with adjustable travel
- 7 positions from 100mm to 400mm
- Strong die-cast aluminium body.
- Rigid or pivot fixing options and various brackets and extension pins to suit most applications (all sold separately).
- High protection degree IP55.
- A robust, centrally positioned double link stainless steel chain with an acoustic device that warns of any eventual incorrect installations.
- All electrical parts are double insulated and supplied with 1.5m cable.
- Available in white (RAL9006), silver (RAL9010) or black.



» Optional Extras

Various brackets available to suit most applications (see below)

- Extension pins to suit:
- E** 30-40mm step
 - F** 20-30mm step
 - G** 10-20mm step

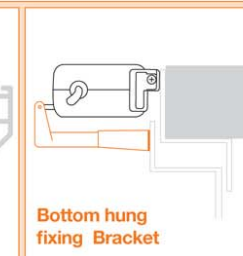
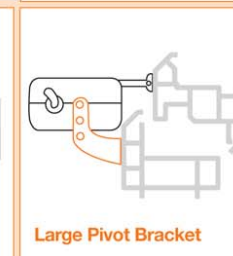
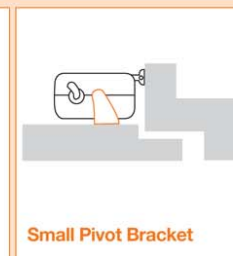
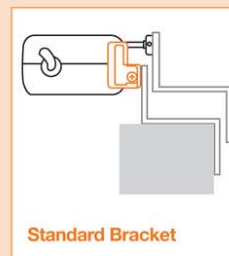
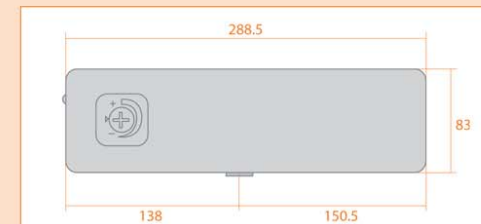



» Technical Specification

Voltage	24V dc	230V ac
Stroke	450/600/800*mm	450/600/800*mm
Thrust Force	400N (*300N)	400N (*300N)
Absorbed Current	2A	0.8A
Speed	20mm/s	23mm/s
Protection Class	IP20	IP20
Wiring	3 core	4 core
Colours Available	White/Dark Brown/Silver	White/Dark Brown/Silver
Limit Stop	Micro Switch	Micro Switch
Safety Stop	Thermic	Thermic

» SuperMaster

» Product Summary

- Heavy duty actuator with powerful thrust and strong, double link stainless steel chain.
- Ideal for heavy windows or windows requiring large opening.
- Choice of 450mm, 600mm or 800mm travel.
- High speed and virtually noiseless operation.
- Minimum window height when using **Slide Brackets**:
900mm for 450mm stroke,
1200mm for 600mm stroke
1600mm for 800mm stroke.
- Minimum window height when using **Pivot Brackets**:
450mm for 450mm stroke
600mm for 600mm stroke
800mm for 800mm stroke.
- All types of fixing brackets supplied separately.

» Standard Colours

- White (RAL 9010)
- Silver Anodised
- Dark Brown Anodised

» Additional Information

Dimensions			
Stroke	450	600	800
Overall Length A	574	650	764
Body Height	50	50	50

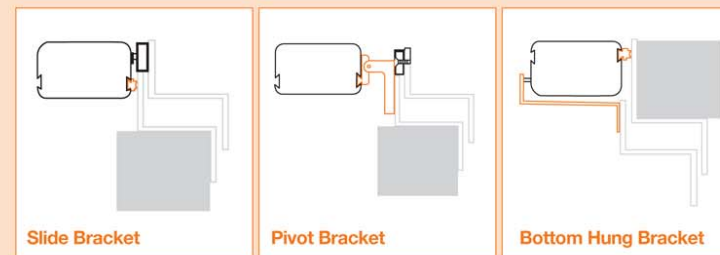

» XP

» Product Summary

- Heavy duty actuator with powerful 400N thrust.
- Double link stainless steel chain.
- Ideal for heavy windows or windows requiring large opening
- Choice of 400mm, 600mm and 800mm stroke.
- Supplied with 1.2m cable.
- Supplied complete with pivot brackets
- Available in White P.C. or Silver Anodized.
- Bottom-Hung fixing brackets available separately

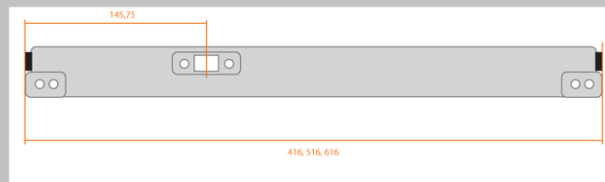
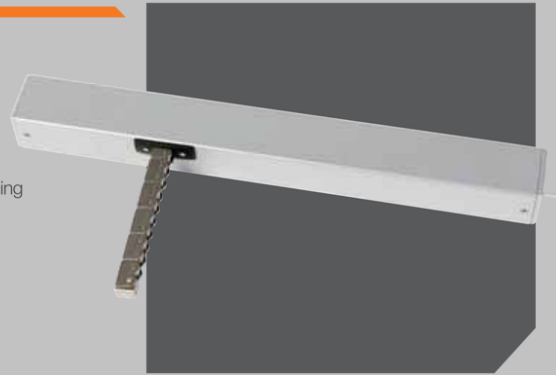

» Technical Specification

Voltage	24V dc
Stroke	400/600/800mm
Thrust Force	400N
Absorbed Current	1A
Speed	10mm/s
Protection Class	IP42
Wiring	2 Core
Colours Available	White/Silver/Black
Limit Stop	Micro-switch
Safety Stop	Thermic

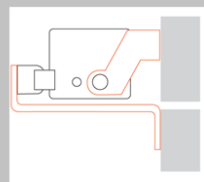

Bottom Hung Bracket

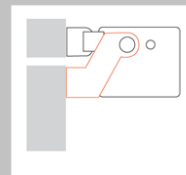

Pivot Bracket

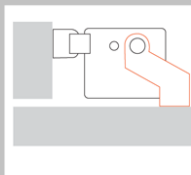

Pivot Bracket

» TwinMaster

» Product Summary

- Twin-Chain 24V dc Actuator with 380mm travel.
- For wide/heavy windows and roof vents.
- Inbuilt electronic circuit to control safe operation of tandem motors.
- Very high force in push and pull action.
- Strong, double link chain.
- Quick release system for easy window cleaning.
- Standard actuator 1230mm long but other lengths available (subject to quantity).
- Minimum window height: 800mm. Use pivot brackets on shallower windows.
- All fixing brackets supplied separately.

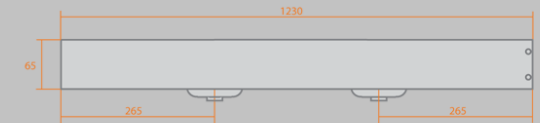

» Technical Specification

Voltage	24V dc
Stroke	380mm
Thrust Force	700N
Absorbed Current	2A
Speed	12mm/s
Protection Class	IP44
Wiring	2 Core
Colours Available	White/Dark Brown/Silver
Limit Stop	Microswitch
Safety Stop	Electronic

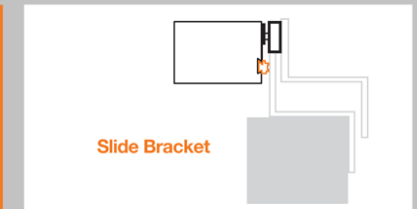

Slide Bracket

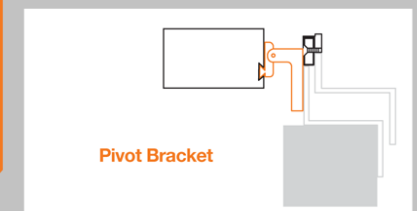

Pivot Bracket

» C240

» MPD

» Product Summary

- Twin - Chain Actuator.
- For wide windows and roof vents.
- Strong double link chain.
- Fast hooking and unhooking system to the window frame.
- Standard range available in 1200mm, 1500mm and 1800mm lengths (other lengths available to order).
- Standard stroke 360mm (*Also available with 240mm stroke by special order).
- Specify Horizontal, Vertical or Bottom-hung brackets when ordering.

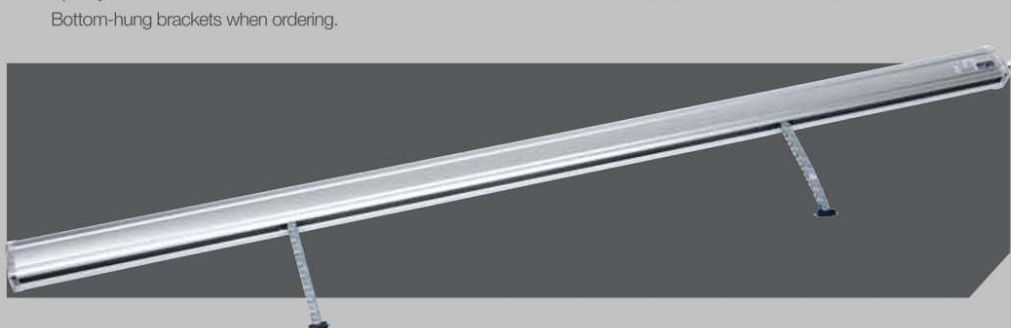

» Technical Specification

Voltage	24V dc	230V ac
Stroke	360mm (*240mm)	360mm (*240mm)
Thrust Force	400N	400N
Absorbed Current	0.75A	0.22A
Speed	7mm/s	7mm/s
Protection Class	IP30	IP30
Wiring	2 Core	3 Core
Colours Available	Silver	Silver
Limit Stop	Electronic	Electronic
Safety Stop	Electronic	Electronic

» Product Summary

- Twin - Chain Actuator.
- For wide windows and roof vents.
- Strong double link chain.
- 1210mm or 1610mm lengths available.
- Adjustable stroke between 150mm and 400mm.
- Supplied complete with pivot brackets.
- Slim profile.
- Bottom-hung brackets available separately

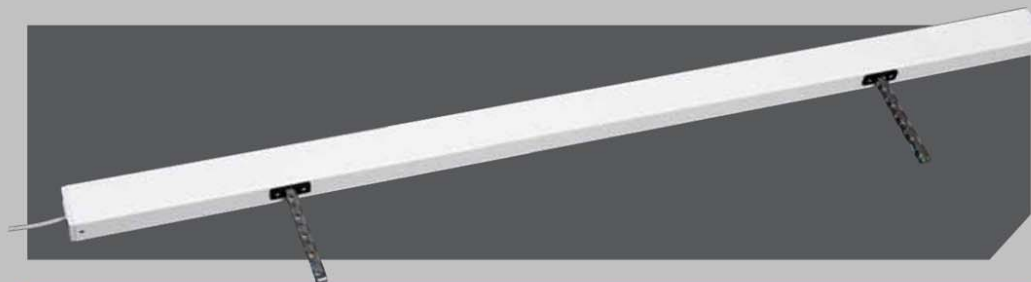
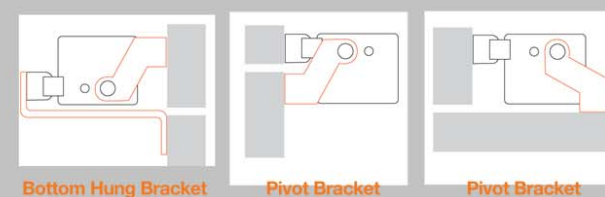

» Technical Specification

Voltage	24V dc	230V ac
Stroke	150-400mm	150-400mm
Thrust Force	400N	400N
Absorbed Current	1A	0.1A
Speed	12mm/s	12mm/s
Protection Class	IP42	IP42
Wiring	2 Core	3 Core
Colours Available	White/Silver/Black	White/Silver/Black
Limit Stop	Electronic	Electronic
Safety Stop	Thermic	Thermic

» Max

» Product Summary

- Linear actuator for roof vents and domes.
- Load transmission by rigid spindle.
- High speed and virtually noiseless operation.
- High protection degree IP65.
- Standard unit supplied with end fixing bracket.
- Supplied with 1.5m cable.
- Slide bracket available as optional extra.
- Choice of 300mm or 500mm travel.

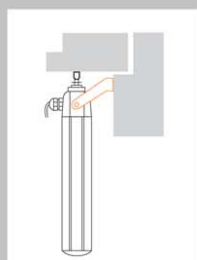
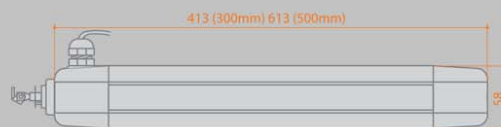

End Bracket

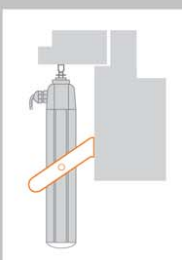

Slide Bracket

» Technical Specification

Voltage	230V ac
Stroke	300/500mm
Force in push-pull action	450N/350N
Absorbed Current	0.7A
Speed	20mm/s
Protection Class	IP65
Wiring	4 Core
Colour	Silver
Limit Stop	Microswitch
Safety Stop	Thermic

» Rack

» Product Summary

- Linear type actuator for use on roof vents or domes.
- Low noise operation.
- High protection degree IP55.
- Supplied with 1.5m cable.
- Available with end brackets or slide brackets, to be ordered separately.
- Choice of 180mm, 350mm, 550mm, 750mm or 1000mm travel.

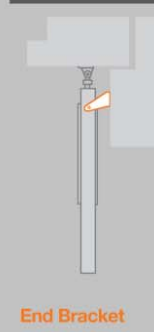
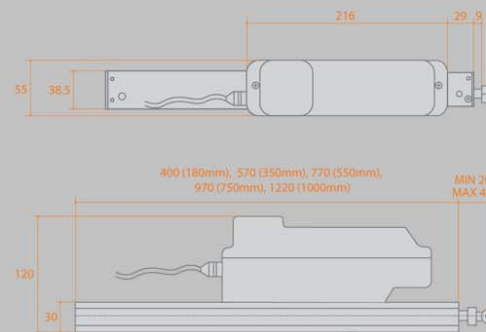

End Bracket

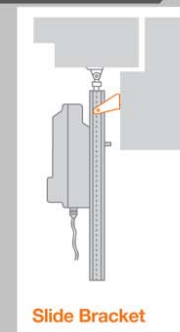

Slide Bracket

» Technical Specification

Voltage	24V dc	230V ac
Stroke	180/350/550/750/1000mm*	180/350/550/750/1000mm*
Thrust Force	650N (*350N)	650N (*350N)
Absorbed Current	1A	0.1A
Speed	8mm/s	8mm/s
Protection Class	IP55	IP55
Wiring	3 Core	4 Core
Colour	Silver	Silver
Limit Stop	Electronic	Electronic
Safety Stop	Electronic	Electronic

» Dual Rack

» Product Summary

- Dual drive linear actuator and slave unit for large, wide roof vents and domes.
- Low noise operation.
- High protection degree IP55.
- Supplied with 1.5m cable.
- Require a pair of end brackets, and connecting rod, sold separately.
- Choice of 1000mm, 1500mm and 2000mm connecting rods.
- Available with 180mm, 350mm, 550mm, 750mm or 1000mm travel.

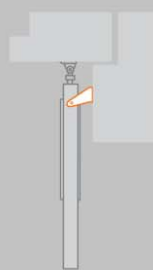
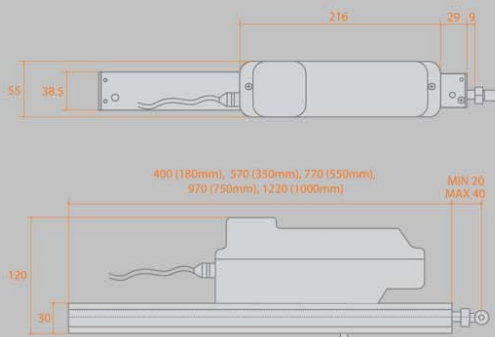
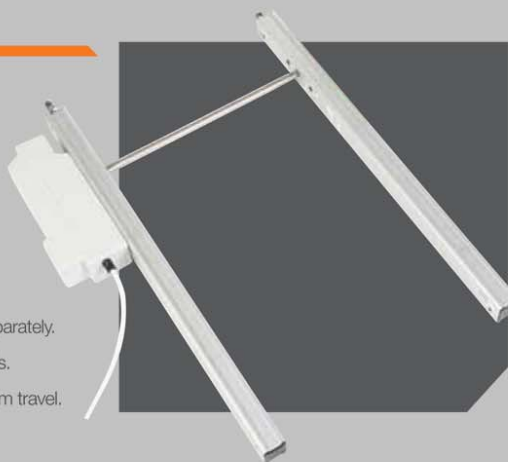

End Bracket

» Technical Specification

Voltage	24V dc	230V ac
Stroke	180/350/550/750/1000mm*	180/350/550/750/1000mm*
Thrust Force	650N (*350N)	650N (*350N)
Absorbed Current	1A	0.1A
Speed	8mm/s	8mm/s
Protection Class	IP55	IP55
Wiring	3 Core	4 Core
Colour	Silver	Silver
Limit Stop	Electronic	Electronic
Safety Stop	Electronic	Electronic

» Double Rack

» Product Summary

- Strong dual drive linear actuators for very heavy, wide roof vents and domes.
- Low noise operation.
- High protection degree IP55.
- Supplied with 1.5m cable.
- Require a pair of end brackets and connecting rod, sold separately.
- Choice of 1000mm, 1500mm and 2000mm connecting rods.
- Available with 180mm, 350mm, 550mm, 750mm or 1000mm travel

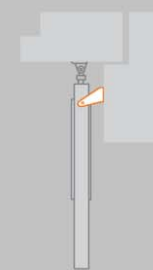
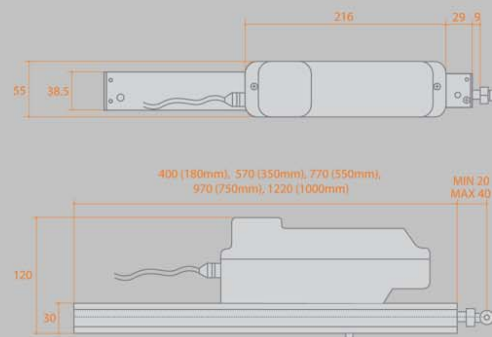
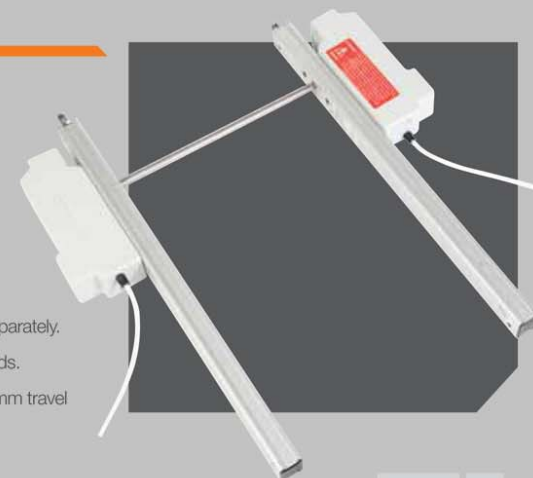

End Bracket

» Technical Specification

Voltage	24V dc	230V ac
Stroke	180/350/550/750/1000mm*	180/350/550/750/1000mm*
Thrust Force	1300N (*700N)	1300N (*700N)
Absorbed Current	2A	0.2A
Speed	8mm/s	8mm/s
Protection Class	IP55	IP55
Wiring	3 Core	4 Core
Colour	Silver	Silver
Limit Stop	Electronic	Electronic
Safety Stop	Electronic	Electronic

» SL60

» Product Summary

- Linear actuator for roof vents and domes.
- High protection degree IP55.
- High speed operation.
- Supplied with 1,3m cable.
- Supplied complete with slide brackets as standard.

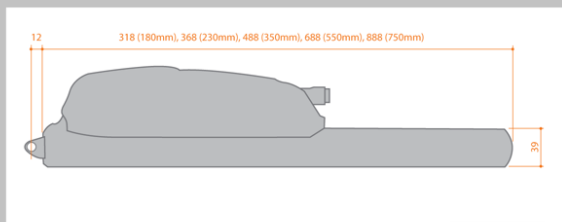
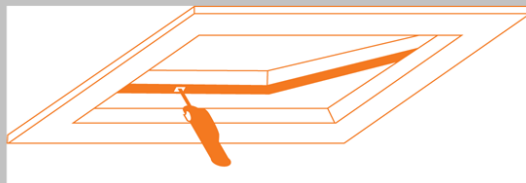

» Technical Specification

Voltage	24V dc	230V ac
Stroke	180/230/350/550/750mm	180/230/350/550/750mm
Thrust Force	600N	600N
Absorbed Current	1.5A	0.32A
Speed	18mm/s	18mm/s
Protection Class	IP55	IP55
Wiring	2 Core	3 Core
Colour	Silver	Silver
Limit Stop	Microswitch	Microswitch
Safety Stop	Thermic	Thermic

» PL6

» Product Summary

- Very strong pair of linear actuators for large/heavy windows, roof vents and domes.
- Provide maximum opening for roof vents, domes and windows.
- Supplied complete with tandem control panel.
- For smoke and heat exhaust systems (SHEVS) and natural ventilation.
- Supplied complete with brackets.



» Technical Specification

Voltage	24V dc
Stroke	300-1000mm
Thrust Force	1200N
Absorbed Current	1.6A
Speed	5.77mm/s
Protection Class	IP65
Wiring	2 Core
Colour	Silver
Limit Stop	Electronic
Safety Stop	Electronic

» ST70



No more hot and stuffy conservatories. The 10 Amp panel automatically controls the operation of 230Vac Actuators fitted to conservatory roof vents to maintain a comfortable environment on those warmer days. There is an integral open / close switch and remote thermostat to control temperature and a rain sensor to close roof vents during rain storms



» ART 230

230V ac Radio receiver with single channel transmitter to control a single actuator or single bank of actuators simultaneously. Can also be used with the PS24 Transformer Unit to operate 24V dc actuators (type of PS24 dependent on number of actuators).



» RRT KEY 2

2 Channel Radio Transmitter to use with the RRT Unit to individually operate 2 actuators or 2 banks of actuators from a single key fob.



» RRT KEY 12

12 Channel Radio Transmitter to use with RRT Unit to individually operate up to 12 actuators or 12 banks of actuators from a single key fob.



» S50

A choice of 1, 2, 3 or 4 gang switches with surface boxes.
10 amp rated, single pole, double throw (centre off) switch for 230V power supplies. Can be used with 24V dc systems linked to VCS panels or relay panels with their own power supplies. Can also be used with the PS24 Transformer.



» RRT KEY

230V ac, 10Amp rated key switch. Supplied complete with 3 keys.



» PS24

2 Amp (50Va) transformer to use with the S50 switch or RRT unit to operate 24V dc actuator/s.
(8 amp version also available by special order)



» TP24 / TP230

Tandem Panel to control a pair of actuators fitted to a single vent.
24V dc or 230V ac versions available.

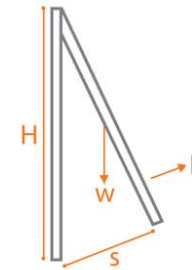

» Example

60 kg window / 1000mm tall / opening 500mm

$$F = \frac{60 \times 500 \times 10}{2 \times 1000}$$

$$F = 30 \times 0.5 \times 10$$

$$F = 150 \text{ Newtons}$$

» Fitting Instructions

Ensure that when the window is fully closed the chain has reached its end stop and the motor is not stalling.

(This can be done electronically with the SuperMaster or manually adjusted with longer extension screw for all other motors.)

The ACK4 has an internal buzzer to indicate that the chain is not fully closed.

For linear type actuators ensure that actuator is fully closed then unscrew end bolt to allow for gasket compression.

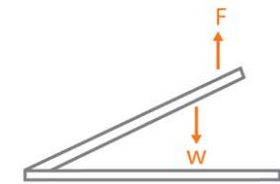

$$F = \frac{W}{2} \times 10$$

W=Weight (kgs)
F=Force (newton's)

» Example

60 kg window / 1000mm tall / opening 500mm

$$F = \frac{60}{2} \times 10$$

$$F = 30 \times 10$$

$$F = 300 \text{ Newtons}$$

» Fitting Instructions

Ensure that the vent bracket and chain end are aligned correctly.

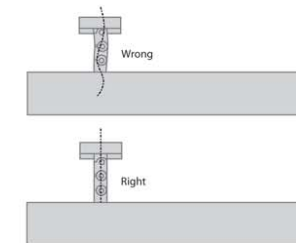

» Smoke
Smoke Control Systems



A range of standard or purpose-made panels, switches and sensors to automatically control virtually every smoke or natural ventilation requirement.



» VCS-1

- Single Zone 10Amp 24V dc Control Panel.
- 72-hour battery back-up on mains failure.
- 300mm x 200mm x 150mm IP65 steel enclosure.
- Sealed lead acid batteries.
- Auto cut off to protect batteries.
- Relay to provide volt free fault indication.
- Close-Auto-Open Function. Front of panel keyswitch to control open, close function of actuators/vents (full override priority).
- Facility to connect smoke heads to automatically reset once smoke has cleared.
- Variable opening of vents option available as special order
- Multi-Zone versions available by special order.



VCS – Battery

Inputs for:

- Fire alarm signal
- Break glass call points
- Smoke detectors
- Heat detectors
- BMS
- Fireman's override switch
- Thermostat
- Rain sensor
- Wind sensor (subject to special order)



» SVCS-1

- Single Zone 2Amp or 2-10Amp 24Vdc Control Panels
- When installed correctly are compliant with EN12101-10.
- 72 hour battery back up on mains failure.
- 300mm x 200mm x 150mm IP65 steel enclosure.
- Sealed lead acid batteries.
- Auto shut down to protect batteries (open vents to fail safe condition first).
- Relay to provide volt free fault indication (when not used for auto-reset feature).
- Open circuit cable detects power supply failures, removal of batteries etc (code fault signal).
- Auto-test – Front of panel keyswitch enables testing and opening and closing of all actuators/vents connected.
- Facility for smoke heads to be automatically reset.
- Multi-Zone versions available by special order.

Inputs for:

- Fire alarm signal
- Break glass call points
- Smoke detectors
- Heat detectors
- Fireman's override switch
- Thermostat (subject to special order)
- Rain sensor (subject to special order)
- Wind sensor (subject to special order)



» Smoke Panels – Purpose Made

» Purpose Made Panels

Purpose made, single or multi-zone panels which can be designed and manufactured for most smoke control or natural ventilation requirements.



» 555

Smoke Sensor and Sounder base.



» 55

Smoke Sensor and base.



» BG1/S

Break glass call point (smoke).



» BG1/F05

Fireman's Override Switch (smoke).



» BG2/F05

Fireman's override keyswitch (smoke).



» RS1

Rain Sensor



» WS1

Wind Sensor



» TS1

Thermostat

