

SECTION A-A

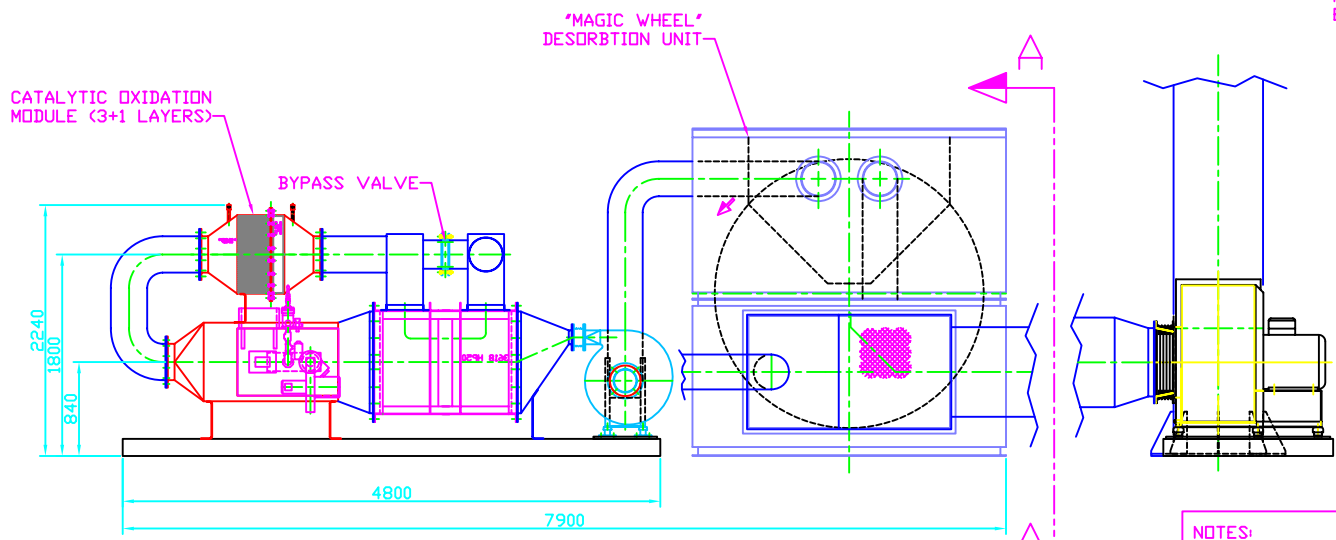

SECOND STAGE HEAT EXCHANGER AND ASSOCIATED DUCTS OMITTED FOR CLARITY

NOTES:
 1. TYPICAL UNIT SHOWN OTHER SIZES AVAILABLE.
 2. RATING DETAILS:
 PROCESS FLOW : 30 000 M3^/HOUR
 DESORBED FLOW : 2 500 M3^/HOUR
 CONCENTRATION RATIO : 12:1
 3. PROCESS DUCT ARRANGEMENT CAN BE ARRANGED TO SUIT SITE LAYOUT.

2		CMH	10/10/11	THE DESIGN HEREIN IS THE PROPERTY OF AIRPROTEKT LTD. AND MAY NOT BE DIVULGED TO ANY THIRD PARTY WITHOUT THE WRITTEN PERMISSION OF AIRPROTEKT LTD.	AIRPROTEKT Ltd REVISIONS: CORRIGENDUM: CIP: 016 TEL: 01455 8282 879933	SCALE	1:25 @A1	UNTOLERANCED DIMENSIONS	APP.	TITLE HONEYCAT CONCENTRATOR SYSTEM GENERAL ARRANGEMENT, PROPOSED	DRG.No.	AP000470
SS	MODIFICATION	SIG.	DATE			DIMENSIONS IN mm	0-25mm ±0.2mm 25-50mm ±0.5mm 50mm PLUS ±1.0mm	APP.	CHK.		DRN.	E.M.H. 22/06/07