



Automation for a Changing World

Delta Intelligent Vector Control Micro Drive C200 Series



Certification
in process

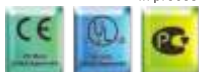

www.delta.com.tw/ia



Features

- Versatile interface provides multi-point inputs, analog inputs, CANopen and MODBUS RS-485 communication for flexible applications
- Simple and fast installation process, parameter setting and tuning functions
- Wall mounting (Frame A)
- Removable high resolution LED keypad with extension cable to maximize operation distance
- Built-in PLC program with 5,000 steps capacity
- Special PCB coating and thermal design for harsh environment applications
 - ▶ Fan cooling with air flow focus to the heatsink, insulates dust and dirt from entering the drive
 - ▶ Instantaneous response to sudden load increase, limiting the amount of current input for a smooth operation
 - ▶ Built-in encoder signal input terminals MI7 and MI8 with a maximum speed up to 33KHZ
 - ▶ Two built-in multi-function output terminals for frequency output with a maximum pulse output up to 33KHz

Built-in High-speed Fieldbus

- Built-in standard MODBUS RS-485 communication interfaces
- **CANopen** (DS402)
 - ▶ Delta CANopen Builder software facilitates the planning process
 - Ability to perform I/O data configuration for all products that support CANopen communication protocol.

Optional Accessories for CANopen

MKCB-HUB01



TAP-CB10

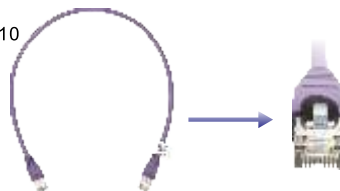

Advanced Control Modes

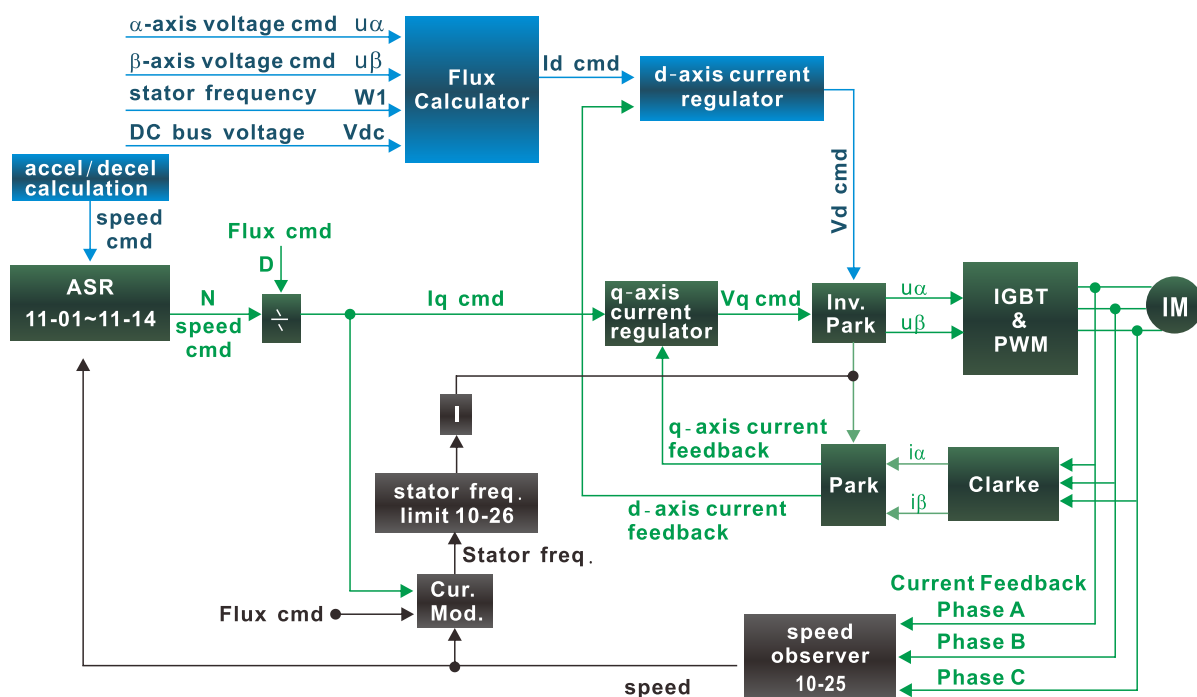

Built-in Programmable Logic Controller (PLC) Function

- Built-in Delta PLC programs. Distributed control and independent operation can be performed when connecting to a network system.



Input Device:

Device	X0	X1	X2	X3	X4	X5	X6	X7	X10	X11	X12	X13	X14	X15	X16	X17
1	FWD	REV	M11	M12	M13	M14	M15	M16	M17	M18						

1: Control board I/O

Output Device:

Device	Y0	Y1	Y2	Y3	Y4	Y5	Y6	Y7	Y10	Y11	Y12	Y13	Y14	Y15	Y16	Y17
1	RY1	RY2		DFM 1	DFM 2											

1: Control board I/O

Model	Capacity
DELTA VFD-C200	5,000 Step
DELTA VFD-E	500 Step

Permanent Magnet Synchronous Motor

- The C200 Series provides PM Sensorless control function for open-loop speed control, suitable for compressors and vacuum pumps.



Field Applications

The C200 Series can be used in a wide range of applications. It is designed for strict safety standards, complete control functions and easy operation.

- Processing machines
- Packaging machines
- Textile machines
- Printing machines
- Material handling machines
- Treadmills
- Fans and pumps
- Solar equipment

Conveyors

Industrial automation has become a trend in many industries and there is increasing demand for conveyor systems to facilitate the manufacturing process. Delta's C200 Series provides excellent control of conveyor systems and has many other benefits:

- ▶ Flexible and space saving installation
- ▶ Adjustable speed
- ▶ Soft-start and soft-stop functions
- ▶ Position control

Features	Avoids spillage and slip-back of materials with C200 Series' soft-start and soft-stop functions
	Facilitates the bottle replacement process. Adjustable speed greatly improves operation efficiency.



Trolley

Features	Improves operation efficiency. Speed is adjustable to cope with different operation needs.
	Minimizes the impact of acceleration and deceleration to the machine

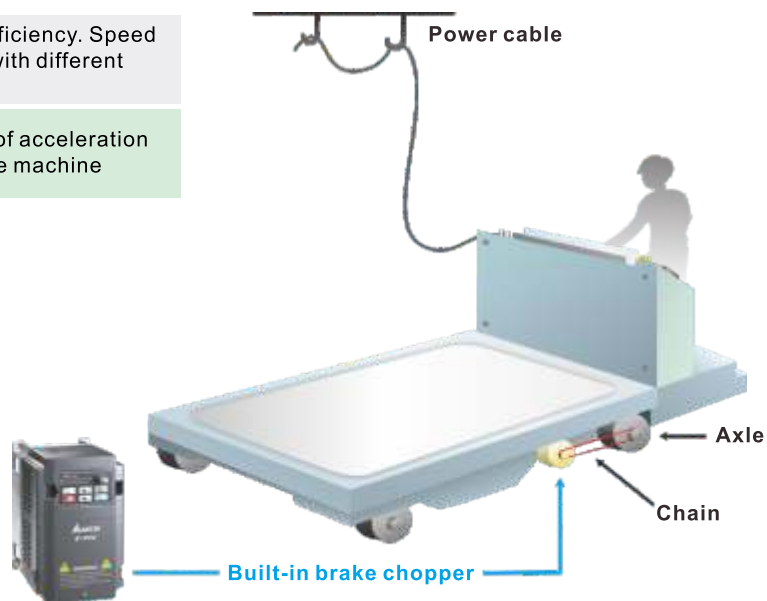

Food Processing Machinery

Inverters have found wide use in food processing machines to improve the processing quality and for safety purposes.

Features	Roller speed is adjustable and perfectly controlled
	Noodle width is adjustable
	Easy operation

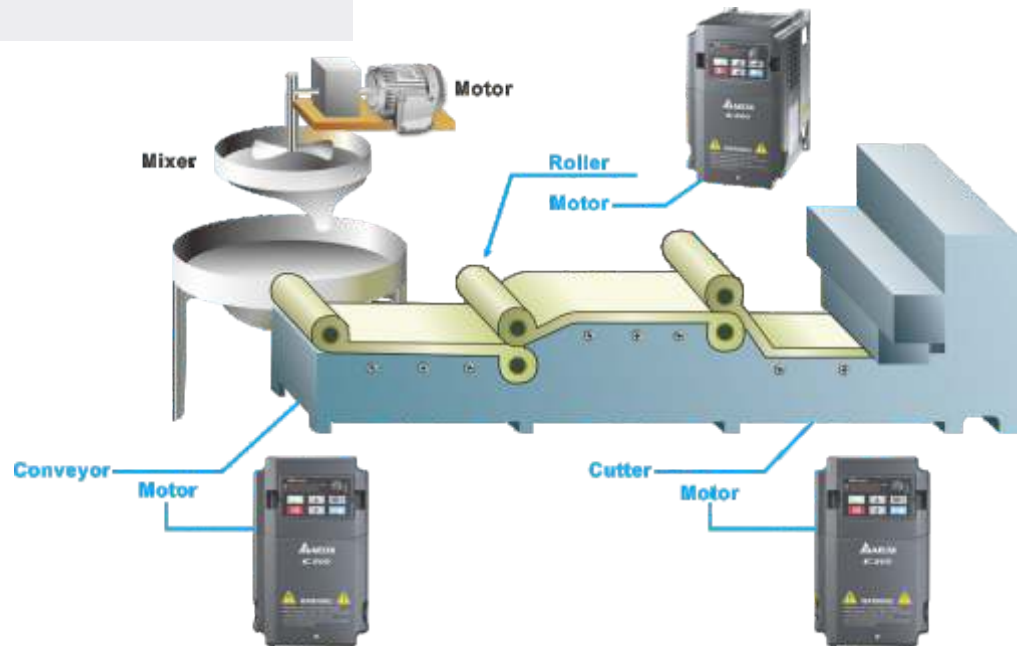

Winding Machinery

The C200 series is capable of responding to an external torque command via its open loop and closed loop torque control functions to execute the rewinding and unwinding of papers, films, fabrics, cables and many other materials.

Features	Provides TQC Sensorless control mode without using an encoder
	Provides TQC+PG control mode with encoder signal feedback from MI7 and MI8.
	Supports various torque command types from keypad, analog inputs, RS-485 or CANopen.

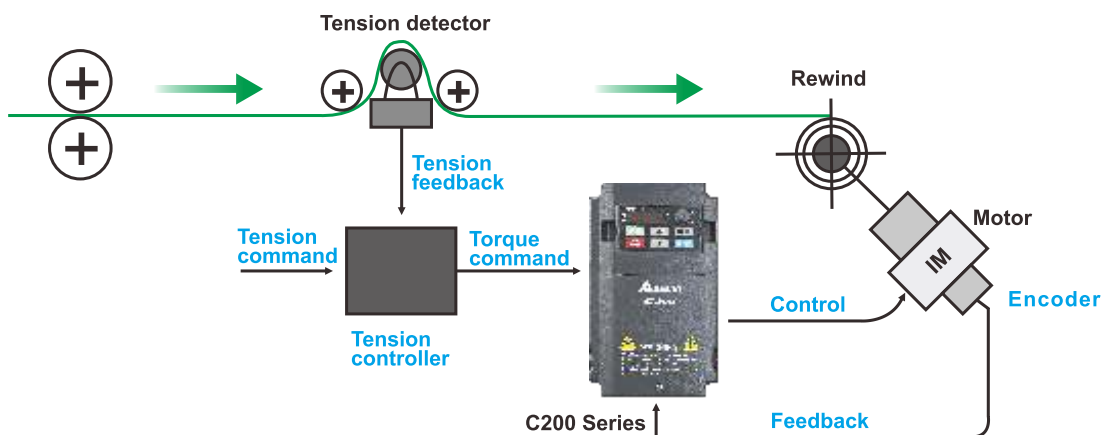

Machine Tools

The C200 Series AC motor drive provides precise speed control, excellent torque output performance at low-speed, and stronger protection in harsh environments while satisfying machine tool requirements.

Features

Past: The spindle speed of a CNC machine tool is generally controlled by a hand wheel to process the different sizes of components.

Now: The Delta C200 Series controls the spindle speed for you and further improves the processing product quality.



Woodworking Machinery

Features

Improves wood cutting efficiency

Adjusts cutting speed for different types of woods

Prevents gear damage using the soft-start function

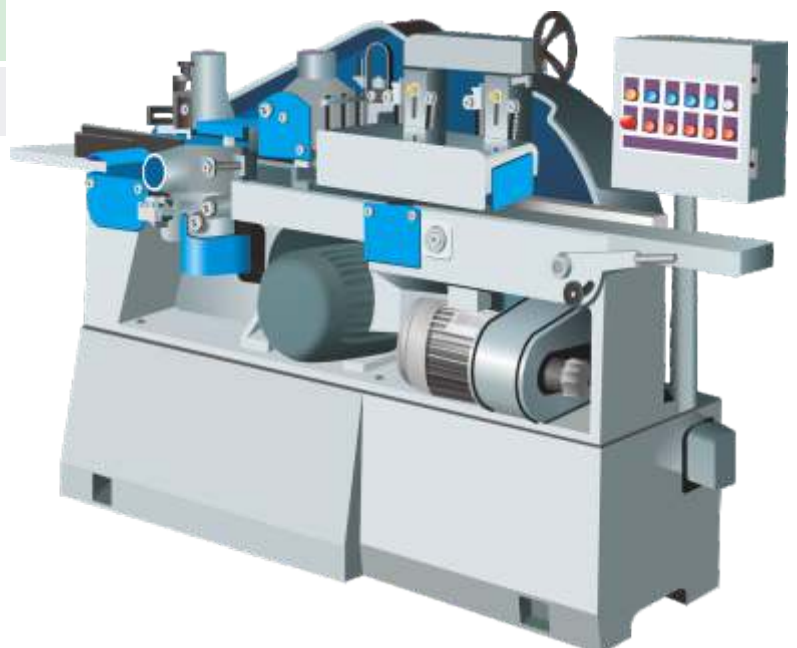

Models

- Built-in high resolution LED panel with turning knob facilitates the turning process
- Saves on wiring



- 1 Status Display**
Indicates the drive's operation status (in operation, stop, FWD, STOP and more)
- 2 LED Display**
Displays the frequency, voltage, current, operation direction, user-defined unit, fault and more
- 3 Frequency Knob**
Master frequency can be set by turning the knob
- 4 Up/Down Key**
Changes the value and parameter settings

Function Key Description

Key	Description
RUN	Starts AC motor drive operation
STOP RESET	Stops AC motor drive operation and resets the drive when a fault occurs

Key	Description
MODE	Selects display mode
ENTER	Reads or changes the drive's parameter settings



Natural cooling models

VFD004CB21A-20/-21/-21M;
 VFD004CB23A-20/-21/-21M;
 VFD007CB21A-20/-21/-21M;
 VFD007CB23A-20/-21/-21M;
 VFD007CB43A-20/-21/-21M;
 VFD015CB43A-20/-21/-21M;



Fan cooling models

VFD015CB21A-20/-21/-21M;
 VFD015CB23A-20/-21/-21M;
 VFD022CB21A-20/-21/-21M;
 VFD022CB23A-20/-21/-21M;
 VFD037CB23A-20/-21/-21M;
 VFD022CB43A-20/-21/-21M;
 VFD037CB43A-20/-21/-21M;
 VFD040CB43A-20/-21/-21M;
 VFD055CB43A-20/-21/-21M;
 VFD075CB43A-20/-21/-21M;

Nameplate

AC Drive Model	MODEL:VFD007CB43A-20
Input Voltage/Current	INPUT: Normal Duty: 3PH 380-480V 50/60Hz 4.3A Heavy Duty: 3PH 380-480V 50/60Hz 4.1A
Output Voltage/Current	OUTPUT: Normal Duty: 3PH 380-480V 3A 2.4KVA 1HP Heavy Duty: 3PH 380-480V 2.9A 2.3KVA 1HP
Frequency Range	FREQUENCY RANGE: Normal Duty: 0-600Hz Heavy Duty: 0-600Hz
Firmware Version	Version:VX.XX
Certifications	
Enclosure rating (IPXX)	
Serial Number	007CBEAIT1080001 DELTA ELECTRONICS, INC. MADE IN XXXXXXXX

Model name

VFD 007 CB 43 A - 20

- Series (Variable Frequency Drive)** - VFD
- Applicable motor power in kW** - 007
004:0.5HP(0.375kW)~
075:10HP(7.5kW)
Refer to the specifications chart for more detail
- C200 series** - CB
- Input voltage** - 43
21:230V 1-Phase
23:230V 3-Phase
43:460V 3-Phase
- Version type** - A
Wall mounted
- IP Protection** - 20
20 : IP20/UL Open Type
21 : IP20/NEMA1
- Case Type** - 20
: Standard model
M : Harsh environment model

Control Terminal

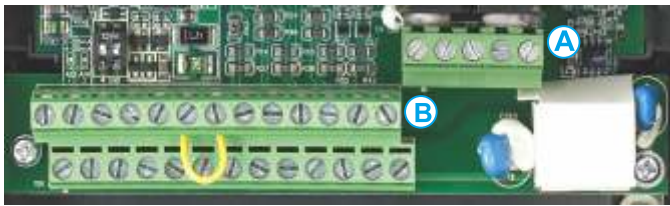

Specifications of the Control Terminal

Wire Gauge : 26~16AWG (0.1281-1.318mm²)



Torque : (A) 5kg-cm [4.31lb-in.] (0.49Nm)

(B) 8kg-cm [6.94lb-in.] (0.78Nm)

* For more detail on specifications, please refer to the user manual of the C200 Series.

Wiring precautions:

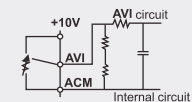
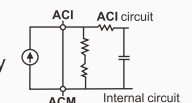
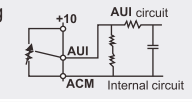
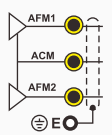
- Reserve 5mm of wire and properly install the wire into the terminal; fasten the installation with a flathead screwdriver. If the wire is stripped, sort the wire before installing it into the terminal.
- Flathead screwdriver: blade width 3.5mm, tip thickness 0.6mm.
- The factory setting for +24V-COM is short circuit and SINK mode (NPN).

Terminals	Terminal Function	Factory Setting (NPN mode)
+24V	Digital control signal common (Source)	+24V±5% 200mA
COM	Digital control signal common (Sink)	Common for multi-function input terminals
FWD	Forward-Stop command	FWD-DCM: ON ->forward run;OFF -> deceleration to stop
REV	Reverse-Stop command	REV-DCM: ON reverse run; OFF deceleration to stop
MI1~MI6	Multi-function input 1~6	Refer to parameters Pr.02-01~Pr.02-08 to program the multi-function inputs MI1~MI8. ON: the activation current is 6.5mA ≧ 11Vdc OFF: leakage current tolerance is 10µA ≦ 11Vdc
MI7~MI8	Multi-function input 7~8	Refer to parameters Pr.02-01~Pr.02-08 to program the multi-function inputs MI1~MI8. It can also be used for PG function with a maximum pulse input of 33kHz.
DFM1	Digital frequency meter 1	Regard the pulse voltage as the output monitor signal
DFM2	Digital frequency meter 2	Duty-cycle: 50%
DCM	Digital frequency signal common	Min. load impedance: 1kΩ/100pf; Max. current: 30mA; Max. voltage: 30Vdc
RA1	Multi-function relay output 1 (N.O.) a	Resistive Load: 5A(N.O.)/3A(N.C.) 250VAC; 5A(N.O.)/3A(N.C.) 30VDC Inductive Load (COS 0.4): 2.0A(N.O.)/1.2A(N.C.) 250VAC; 2.0A(N.O.)/1.2A(N.C.) 30VDC
RB1	Multi-function relay output 1 (N.C.) b	
RC1	Multi-function relay common	It is used to output the monitoring signal, such as drive is in operation, frequency attained or overload indication.
RA2	Multi-function relay output 2 (N.O.) a	
RC2	Multi-function relay output 2 common	
+10V	Potentiometer power supply	Analog frequency setting: +10Vdc 20mA
AVI	Analog voltage input 	Impedance: 20kΩ Range: 4 ~ 20mA/0~10V = 0~Max. Output Frequency (Pr.01-00) Factory setting of AVI switch is 0~10V
ACI	Analog current input Frequency command 	Impedance: 500Ω Range: 4 ~ 20mA/0~10V = 0 ~ Max. Output Frequency (Pr.01-00) Factory setting of ACI switch is 4~20mA
AUI	Auxiliary analog voltage input Frequency command 	Impedance: 20kΩ Range: -10~+10VDC=0 ~ Max. Output Frequency(Pr.01-00)
AFM1		Impedance: 100kΩ (voltage output) Range: 0~10V Output voltage: 0~10V max Resolution: 0~10V corresponds to max. operation frequency
AFM2		Impedance: 100kΩ (voltage output) Range: 0~20mA/ 4~20mA Output current: 20mA max Resolution: 0~20mA/ 4~20mA corresponds to max. operation frequency
ACM	Analog Signal Common	Common for analog terminals
SG+ / SG-		RJ-45 connector, MODBUS RS-485

* Wire size of analog control signals: 18 AWG (0.75 mm²), shielded wire

Specifications of the Main Circuit Terminals

Frame A0

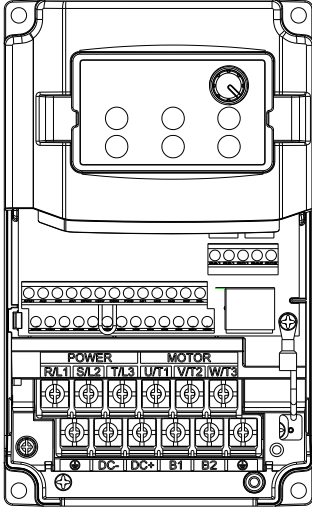

Main circuit terminals : R/L1, S/L2, T/L3, U/T1, V/T2, W/T3, ⊕, DC+, DC-, B1, B2			
Models	Max. Wire Gauge	Min. Wire Gauge	Torque (±10%)
VFD004CB21A-20/-21/-21M	8 AWG (8.4mm ²)	14 AWG (2.1mm ²)	M4 20kg-cm (17.4 lb-in.) (1.96Nm)
VFD007CB21A-20/-21/-21M		12 AWG (3.3mm ²)	
VFD015CB21A-20/-21/-21M		10 AWG (5.3mm ²)	
VFD022CB21A-20/-21/-21M		8 AWG (8.4mm ²)	
VFD004CB23A-20/-21/-21M		14 AWG (2.1mm ²)	
VFD007CB23A-20/-21/-21M		14 AWG (2.1mm ²)	
VFD015CB23A-20/-21/-21M		12 AWG (3.3mm ²)	
VFD022CB23A-20/-21/-21M		10 AWG (5.3mm ²)	
VFD037CB23A-20/-21/-21M		8 AWG (8.4mm ²)	
VFD007CB43A-20/-21/-21M		14 AWG (2.1mm ²)	
VFD015CB43A-20/-21/-21M		14 AWG (2.1mm ²)	
VFD022CB43A-20/-21/-21M		14 AWG (2.1mm ²)	
VFD037CB43A-20/-21/-21M		10 AWG (5.3mm ²)	

Terminal DC+ and DC-: Torque is 45 kg-cm [39.0 lb-in.] (4.415Nm) (±10%)

Figure 2 shows the specification of insulated heat shrink tubing complies with UL standard (600V, YDPU2).

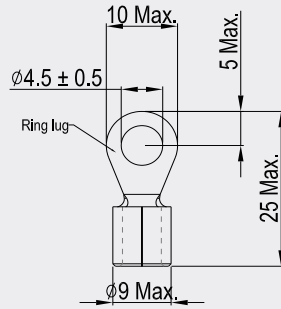

Figure 1.

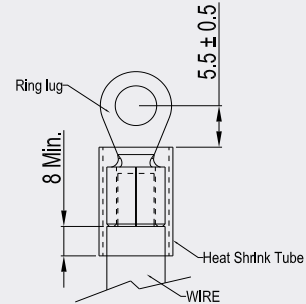
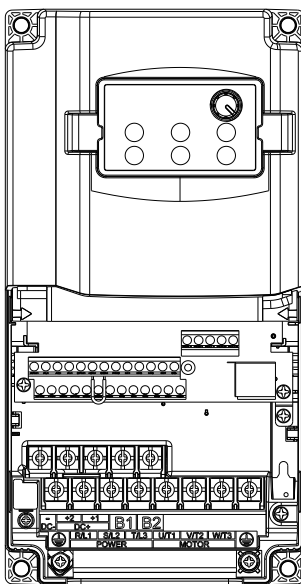

Figure 2.

Frame A



Main circuit terminals : R/L1, S/L2, T/L3, U/T1, V/T2, W/T3, ⊕, DC+ (+2, +1), DC-, B1, B2			
Models	Max. Wire Gauge	Min. Wire Gauge	Torque (±10%)
VFD040CB43A-20/-21/-21M	8AWG (8.4mm ²)	10 AWG (5.3mm ²)	M4 20kg-cm (17.4 lb-in.) (1.96Nm)
VFD055CB43A-20/-21/-21M		10 AWG (5.3mm ²)	
VFD075CB43A-20/-21/-21M		8 AWG (8.4mm ²)	

Terminal DC+ and DC-: Torque is 45 kg-cm [39.0 lb-in.] (4.415Nm) (±10%)

Figure 2 shows the specification of insulated heat shrink tubing complies with UL standard (600V, YDPU2).

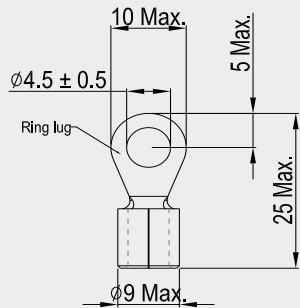

Figure 1.

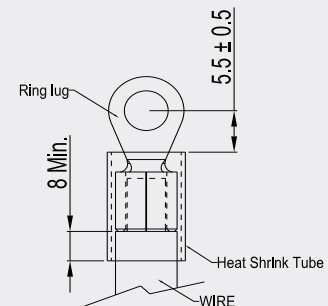

Figure 2.

Product Specifications

230V		Frame Size	A0 (1-Phase)				A0 (3-Phase)						
		Model VFD-__CB2_A-__*1	004	007	015	022	004	007	015	022	037		
		Applicable Motor Output (kW)	0.4	0.75	1.5	2.2	0.4	0.75	1.5	2.2	3.7		
		Applicable Motor Output (hp)	0.5	1	2	3	0.5	1	2	3	5		
Output Rating	Normal Duty	Rated Output Capacity (kVA)	1.2	2.0	3.2	4.4	1.2	2.0	3.2	4.4	6.8		
		Rated Output Current (A)	3	5	8	11	3	5	8	11	17		
		Overload Capacity	Rated output current: 120% for 1 minute; 160% for 3 seconds										
	Heavy Duty	Max. Output Frequency (Hz)	600.00Hz										
		Carrier Frequency (kHz)	2~15kHz (Factory setting : 8 kHz)										
		Rate Output Capacity (kVA)	1.1	1.9	2.8	4.0	1.1	1.9	2.8	4.0	6.4		
		Rated Output Current (A)	2.8	4.8	7.1	10	2.8	4.8	7.1	10	16		
		Overload Capacity	Rated output current: 150% for 1 minute; 180% for 3 seconds										
		Max. Output Frequency (Hz)	600.00Hz										
		Carrier Frequency (kHz)	2~15kHz (Factory setting : 2 kHz)										
Input Rating	Input Current (A) of Normal Duty		7.2	12	15.7	22	3.9	6.4	12	16	20		
	Input Current (A) of Heavy Duty		6.7	11.5	14	20	3.6	6.1	11	15	18.5		
	Rated Voltage/Frequency		1-phase/ 3-phase AC 200V~240V (-15% ~ +10%) , 50/60Hz										
	Range of Operating Voltage		170~265Vac										
	Frequency Tolerance		47~63Hz										
		Cooling method	Natural cooling			Fan cooling			Natural cooling			Fan cooling	
		Braking Chopper	Built-in										

460V		Frame Size	A0 (1-Phase)				A0 (3-Phase)				
		Model VFD-__CB43A-__*1	007	015	022	037	040	055	075		
		Applicable Motor Output (kW)	0.75	1.5	2.2	3.7	4.0	5.5	7.5		
		Applicable Motor Output (hp)	1	2	3	5	5.5	7.5	10		
Output Rating	Normal Duty	Rated Output Capacity (kVA)	2.4	3.2	4.8	7.2	8.4	10	14		
		Rated Output Current (A)	3.0	4.0	6.0	9.0	10.5	12	18		
		Overload Capacity	Rated output current: 120% for 1 minute; 160% for 3 seconds								
	Heavy Duty	Max. Output Frequency (Hz)	600.00Hz								
		Carrier Frequency (kHz)	2~15kHz (Factory setting : 8 kHz)								
		Rate Output Capacity (kVA)	2.3	3.0	4.5	6.5	7.6	9.6	14		
		Rated Output Current (A)	2.9	3.8	5.7	8.1	9.5	11	17		
		Overload Capacity	Rated output current: 150% for 1 minute; 180% for 3 seconds								
		Max. Output Frequency (Hz)	600.00Hz								
		Carrier Frequency (kHz)	2~15kHz (Factory setting : 2 kHz)								
Input Rating	Input Current (A) of Normal Duty		4.3	5.9	8.7	14	15.5	17	20		
	Input Current (A) of Heavy Duty		4.1	5.6	8.3	13	14.5	16	19		
	Rated Voltage/Frequency		3-Phase AC 380V~480V (-15% ~ +10%) , 50/60Hz								
	Range of Operating Voltage		323~528Vac								
	Frequency Tolerance		47~63Hz								
		Cooling method	Natural cooling				Fan cooling				
		Braking Chopper	Built-in								

*1: __ __ refers to models -10/-21/-21M

Operation Temperature and Enclosure Type

Models	Frames	Protection Class	Operation Temperature
VFDxxxCBxxA-20	Frame A0~A 230V: 0.4~3.7kW 460V: 0.4~7.5kW	IP20/UL Open Type	-10~50℃
VFDxxxCBxxA-21	Frame A0~A 230V: 0.4~3.7kW 460V: 0.4~7.5kW	IP20/NEMA1	-10~40℃
VFDxxxCBxxA-21M ^{*2}	Frame A0~A 230V: 0.4~3.7kW 460V: 0.4~7.5kW	IP20/NEMA1	-10~40℃

*2: Models with model name ending in -21M have enhanced enclosure protection design. Rated operation temperature of -10~35 degree is 100%. If the temperature rises above 36 degree, current decreases by 2% for every 1 degree of increases in temperature.

General Specifications

Control Characteristics	Control Method	V/F, V/F+PG, SVC, FOC Sensorless*, FOC+PG, PM Sensorless, TQC+PG, TQC Sensorless*
	Starting Torque	Reach up to 150% or above at 0.5Hz. In FOC+PG mode, starting torque reaches above 150% at 0.5Hz and reaches 150% at 0Hz for 1 minute.
	Speed Response Ability	5Hz (vector control can reach up to 40Hz)
	Torque Limit	Normal duty: max. 160% torque current; Heavy duty: max. 180% torque current
	Torque Accuracy	±5%
	Max. Output Frequency (Hz)	Normal duty: 0.01~600.00Hz; Heavy duty: 0.00 ~ 300.00 Hz
	Frequency Output Accuracy	Digital command:0.01%, -10°C~+40°C, Analog command: 0.1%, 2510°C
	Output Frequency Resolution	Digital command:0.01Hz, Analog command: 0.03 x max. output frequency / 60 Hz (11 bit)
	Frequency Setting Signal	+10V~-10 · 0~+10V · 4~20mA
	Accel./decel. Time	0.0~6000.0seconds
Protection Characteristics	Main control functions	Torque control, Droop control, Speed/torque control switching, Feed forward control, Momentary power loss ride thru, Speed search, Over-torque detection, Torque limit, 17-step speed (max), Accel/decel time switch, S-curve accel/decel, 3-wire sequence, Auto-Tuning (rotational, stationary), Dwell, Cooling fan on/off switch, Slip compensation, Torque compensation, JOG frequency, Frequency upper/lower limit settings, DC injection braking at start/stop, High slip braking, PID control (with sleep function), Energy saving control, MODBUS communication (RS-485 RJ45, max. 115.2 kbps), Fault restart, Parameter copy
	Fan Control	Fan operation can be set by Pr.07-19
	Motor Protection	Electronic thermal relay protection
	Over-current Protection	Over-current protection for 240% rated current Current clamp 『Normal duty: 170~175%』 ; 『Heavy duty: 180~185%』
	Over-voltage Protection	230: drive will stop when DC-BUS voltage exceeds 410V 460: drive will stop when DC-BUS voltage exceeds 820V
	Over-temperature Protection	Built-in temperature sensor
	Stall Prevention	Stall prevention during acceleration, deceleration and running independently
Grounding Leakage Current Protection	Leakage current is higher than 50% of rated current of the AC motor drive	

* FOC Sensorless, TQC Sensorless function will be available on 2012 Q2.

Environment for Operation, Storage and Transportation

DO NOT expose the AC motor drive to harsh environments, such as dust, direct sunlight, corrosive/inflammable gasses, humidity, liquids or vibrations. Salt in the air must be less than 0.01mg/cm² every year.

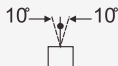
Environment	Installation location	IEC60364-1/IEC60664-1 Pollution degree 2 · Indoor use only	
	Surrounding Temperature	Storage/ Transportation	-25°C ~ +70°C
		Non-Dewfall, non-conductive	
	Rated Humidity	Operation	Max. 90%
		Storage/ Transportation	Max. 95%
	Non-Dewfall, non-conductive		
	Air Pressure	Operation/ Storage	86 to 106 kPa
		Transportation	70 to 106 kPa
	Pollution Level	IEC721-3-3	
		Operation	Class 3C2 : Class 3S2
Storage		Class 2C2 : Class 2S2	
Transportation		Class 1C2 : Class 1S2	
Non-Dewfall, non-conductive			
Altitude	Operation	If AC motor drive is installed at altitude 0~1000m, follow normal operation restrictions.	
		If it is installed at altitude 1000~3000m, decrease 2% of rated current or lower 0.5°C of temperature for every 100m increase in altitude. Maximum altitude for Corner Grounded is 2000m.	
Package Drop	Storage/ Transportation	ISTA procedure 1A(according to weight) IEC60068-2-31	
Vibration	1.0mm, peak to peak value range from 2Hz to 13.2 Hz; 0.7G~1.0G range from 13.2Hz to 55Hz; 1.0G range from 55Hz to 512 Hz. Comply with IEC 60068-2-6		
Impact	IEC/EN 60068-2-27		
Operation Position	Max. allowed offset angle 10o (under normal installation position)		

Wiring

It provides 1-phase/3-phase power

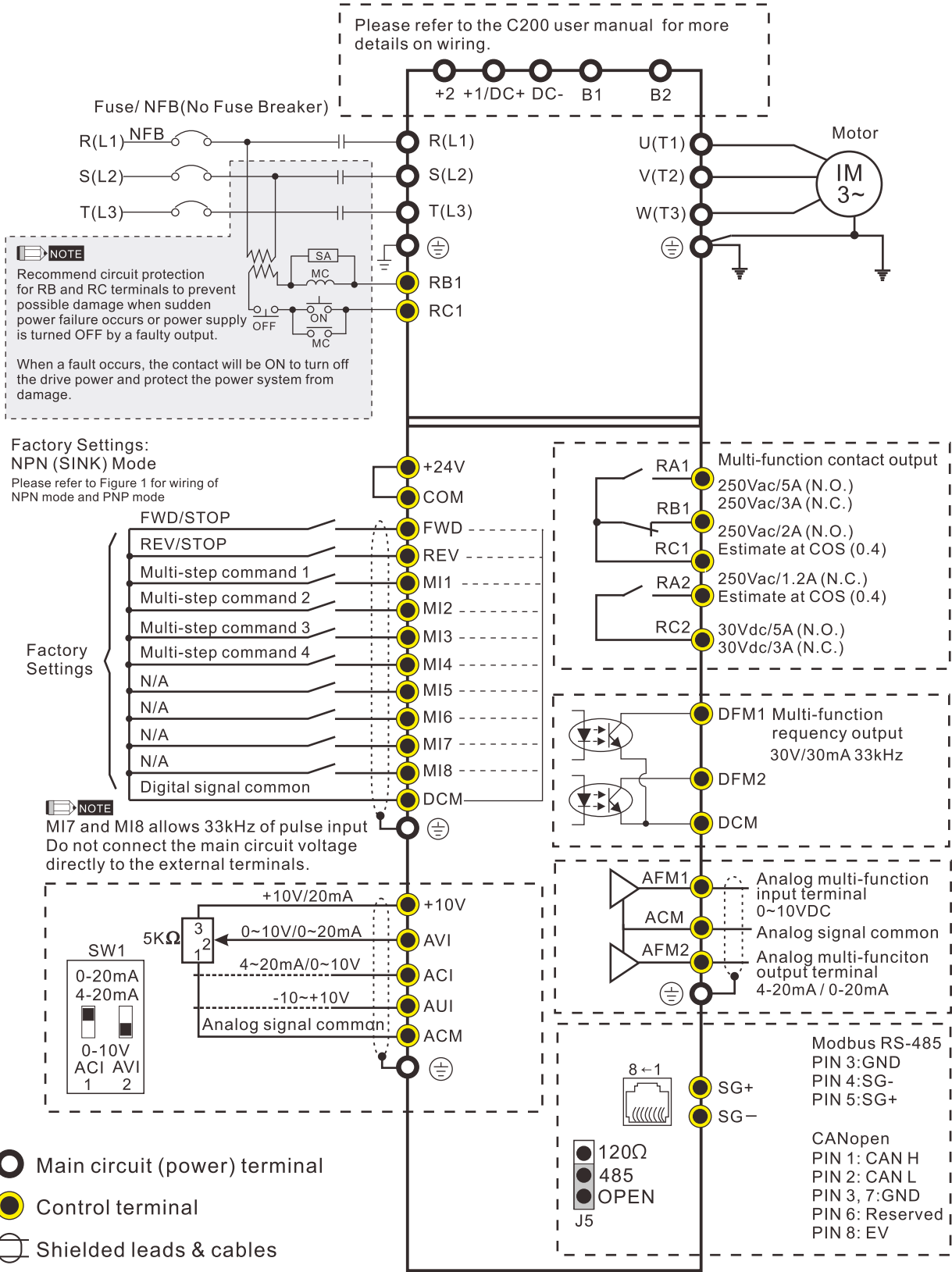

Dimensions of Accessories

KPC-CC01 & KPC-CE01

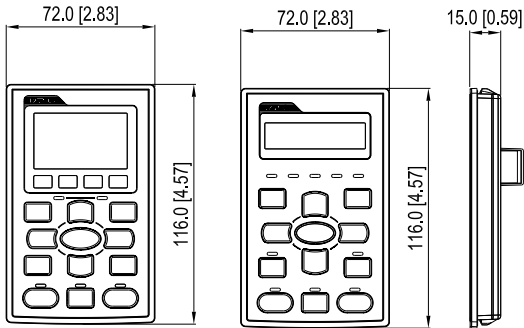

MKCB-HUB01

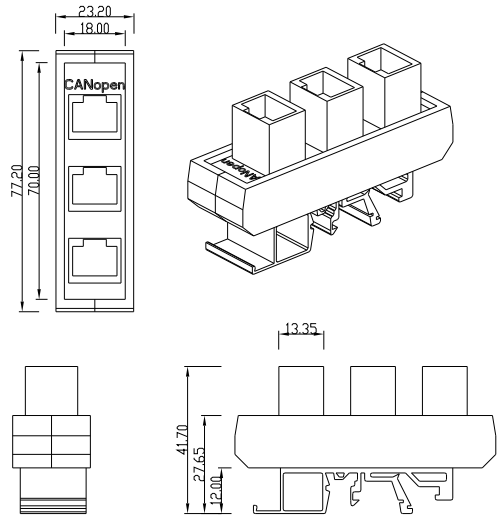

Dimensions

Frame A0

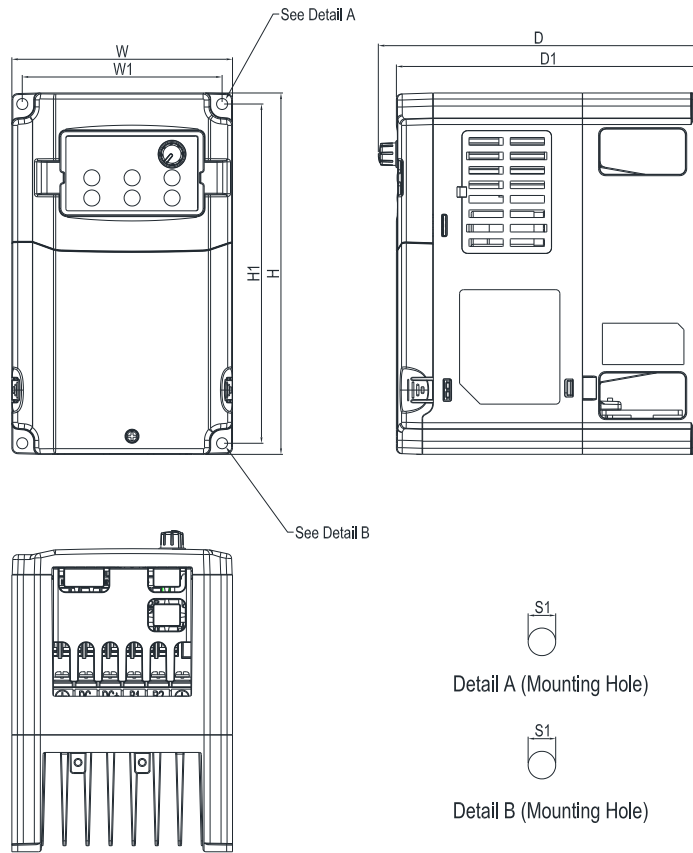

MODEL

- VFD004CB21A-20
- VFD007CB21A-20
- VFD004CB23A-20
- VFD007CB23A-20
- VFD007CB43A-20
- VFD015CB43A-20
- VFD015CB23A-20 (Built-in fan module)

Frame		W	H	D	W1	H1	D1	S1	Ø1	Ø2	Ø3
A0	mm	110.0	180.0	160.0	99.6	169.0	151.0	5.5	-	-	-
	inch	4.33	7.09	6.30	3.92	6.65	5.94	0.22	-	-	-

Dimensions

Frame A0

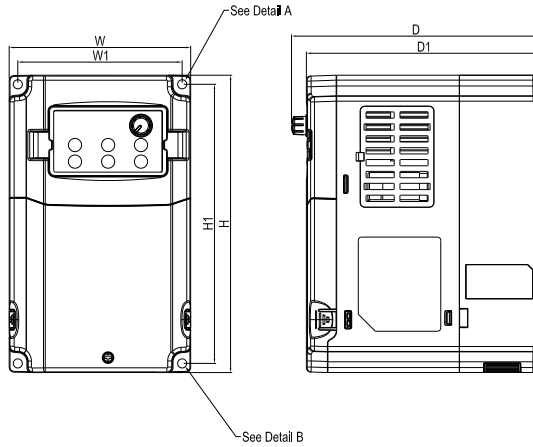

MODEL

- VFD015CB21A-20
- VFD022CB21A-20
- VFD022CB23A-20
- VFD037CB23A-20
- VFD022CB43A-20
- VFD037CB43A-20

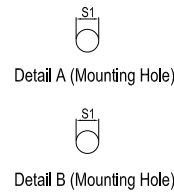
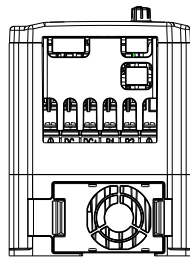

Frame		W	H	D	W1	H1	D1	S1	Ø1	Ø2	Ø3
A0	mm	110.0	180.0	151.0	99.6	169.0	142.0	5.5	-	-	-
	inch	4.33	7.09	5.94	3.92	6.65	5.59	0.22	-	-	-

Frame A0

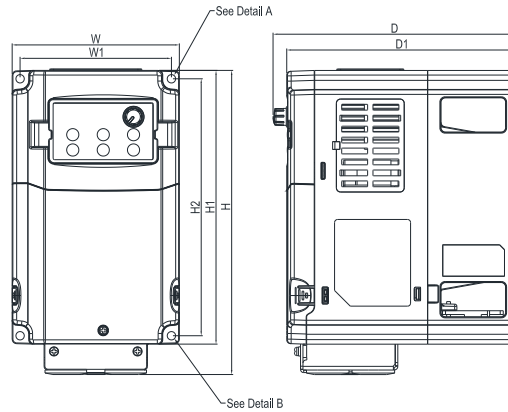

MODEL

- VFD004CB21A-21
- VFD007CB21A-21
- VFD004CB23A-21
- VFD007CB23A-21
- VFD007CB43A-21
- VFD015CB43A-21
- VFD015CB23A-21 (Built-in fan module)

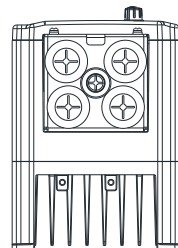

Frame		W	H	D	W1	H1	H2	D1	S1	Ø1	Ø2	Ø3
A0	mm	110.0	200.0	160.0	99.6	180.0	169.0	151.0	5.5	-	-	-
	inch	4.33	7.87	6.30	3.92	7.09	6.65	5.94	0.22	-	-	-

Frame A0

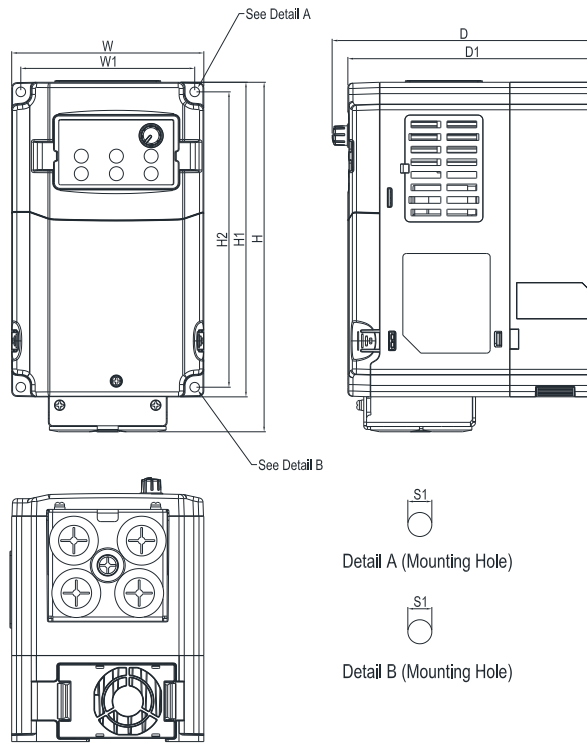

MODEL

VFD015CB21A-21
 VFD022CB21A-21
 VFD022CB23A-21
 VFD037CB23A-21
 VFD022CB43A-21
 VFD037CB43A-21

Frame		W	H	D	W1	H1	H2	D1	S1	Ø1	Ø2	Ø3
A0	mm	110.0	200.0	151.0	99.6	180.0	169.0	142.0	5.5	-	-	-
	inch	4.33	7.87	5.94	3.92	7.09	6.65	5.59	0.22	-	-	-

Frame A0

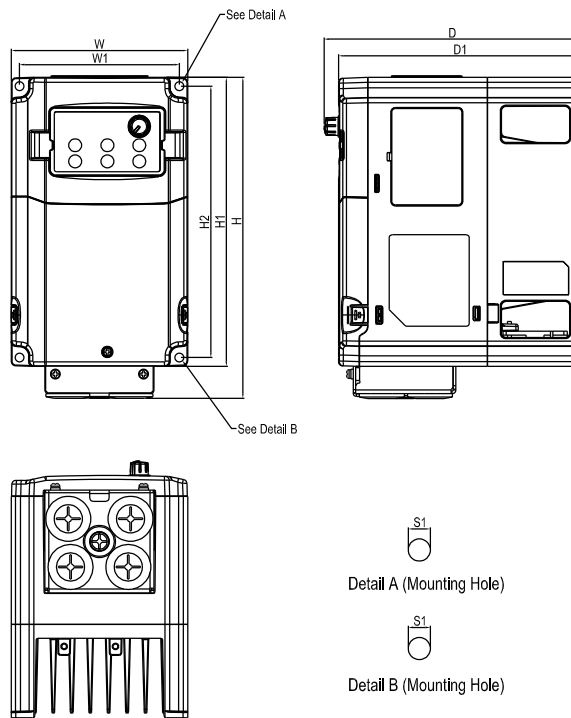

MODEL

VFD004CB21A-21M
 VFD007CB21A-21M
 VFD004CB23A-21M
 VFD007CB23A-21M
 VFD007CB43A-21M
 VFD015CB43A-21M
 VFD015CB23A-21M (Built-in fan module)

Frame		W	W1	H	H1	H2	D	D1	S1	Ø1	Ø2
A0	mm	110.0	99.6	200.0	180.0	169.0	160.0	151.0	5.5	-	-
	inch	4.33	3.92	7.87	7.09	6.65	6.30	5.94	0.22	-	-

Dimensions

Frame A0

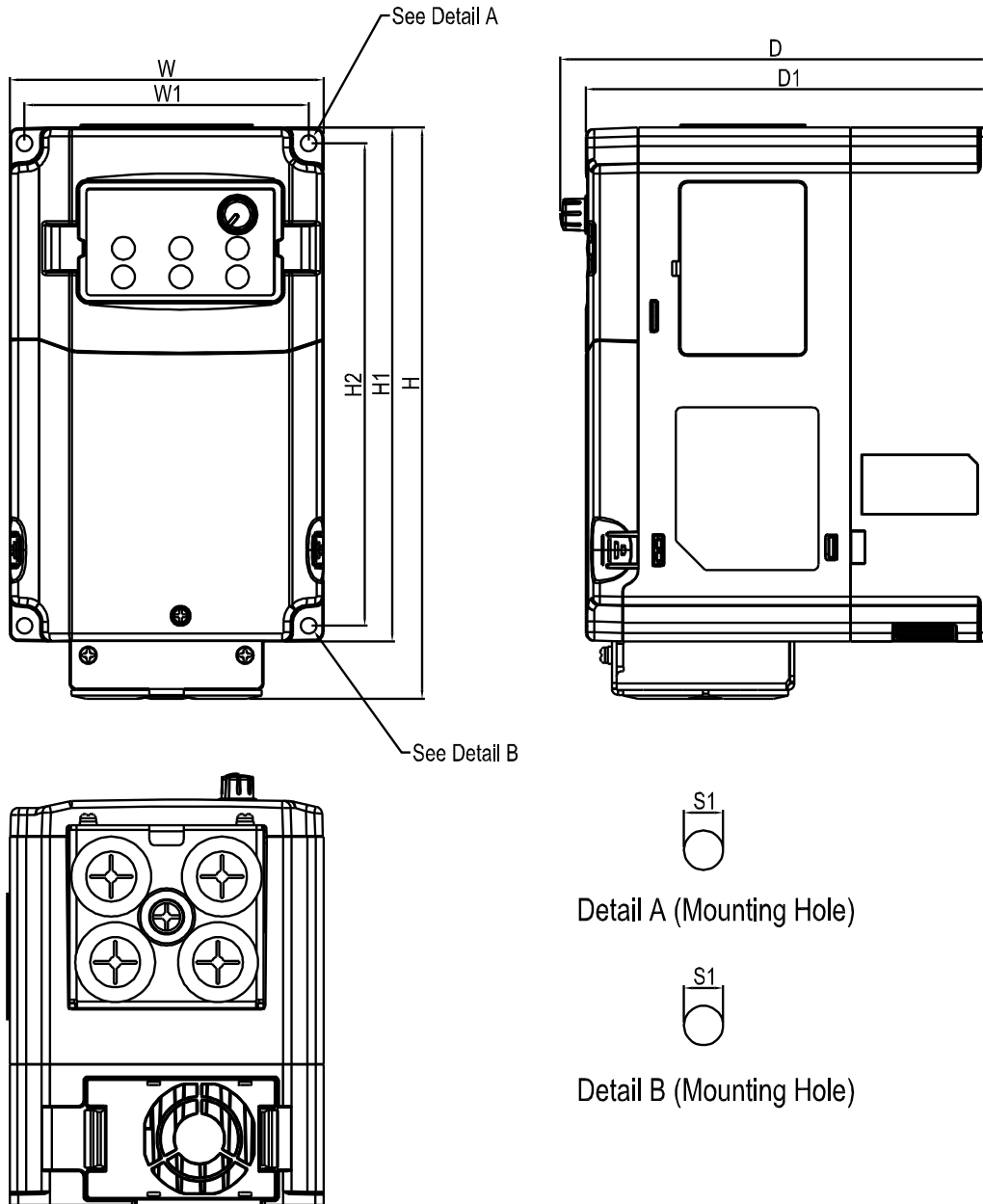

MODEL

- VFD015CB21A-21M
- VFD022CB21A-21M
- VFD022CB23A-21M
- VFD037CB23A-21M
- VFD022CB43A-21M
- VFD037CB43A-21M

Frame		W	W1	H	H1	H2	D	D1	S1	Ø1	Ø2
A0	mm	110.0	99.6	200.0	180.0	169.0	151.0	142.0	5.5	-	-
	inch	4.33	3.92	7.87	7.09	6.65	5.94	5.59	0.22	-	-

Dimensions

Frame A

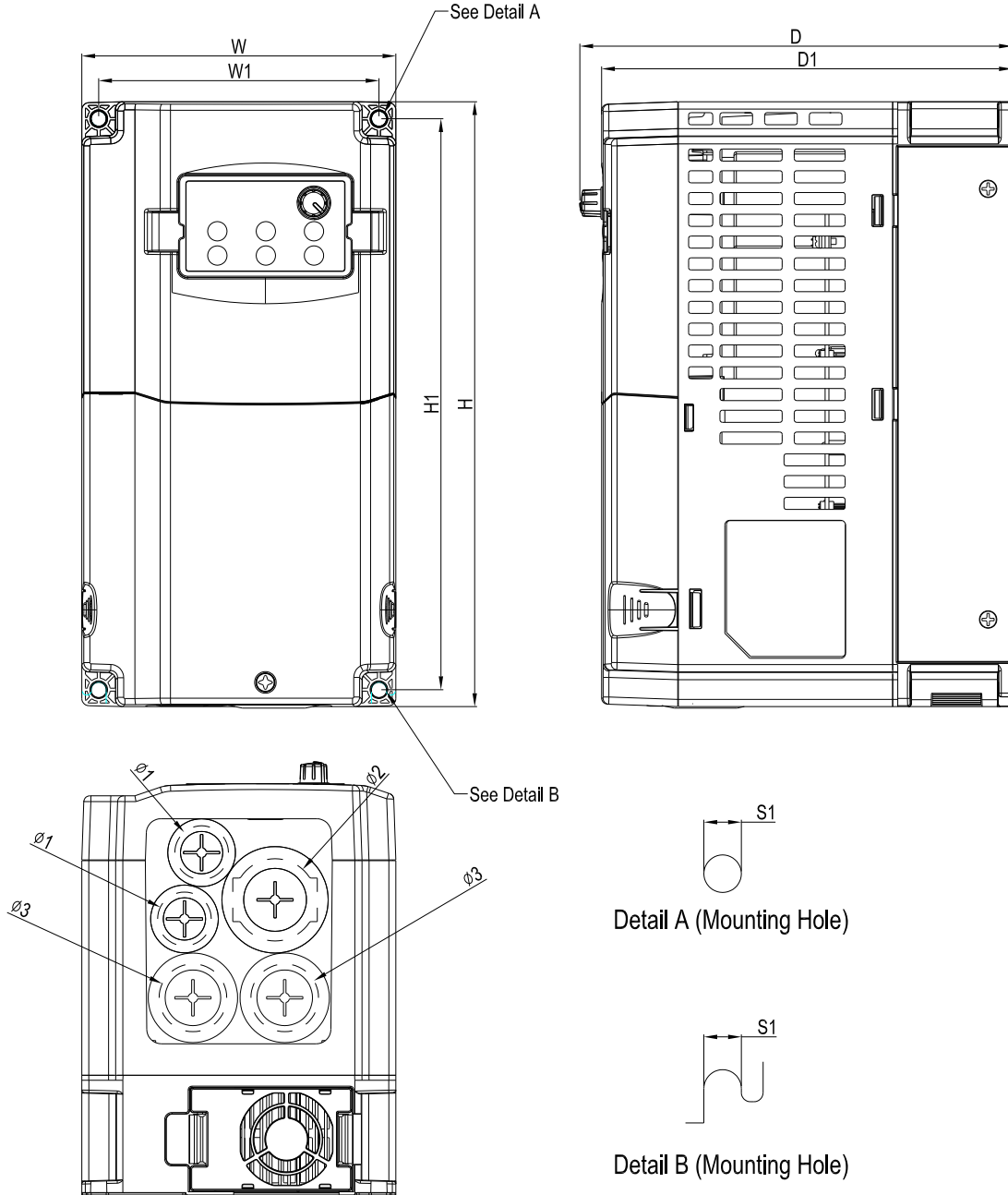

MODEL

- VFD040CB43A-20
- VFD055CB43A-20
- VFD075CB43A-20
- VFD040CB43A-21
- VFD055CB43A-21
- VFD075CB43A-21

Frame		W	H	D	W1	H1	D1	S1	Ø1	Ø2	Ø3
A	mm	130.0	250.0	179.0	116.0	236.0	170.0	6.2	22.2	34.0	28.0
	inch	5.12	9.84	7.05	4.57	9.29	6.69	0.24	0.87	1.34	1.10

Dimensions

Frame A

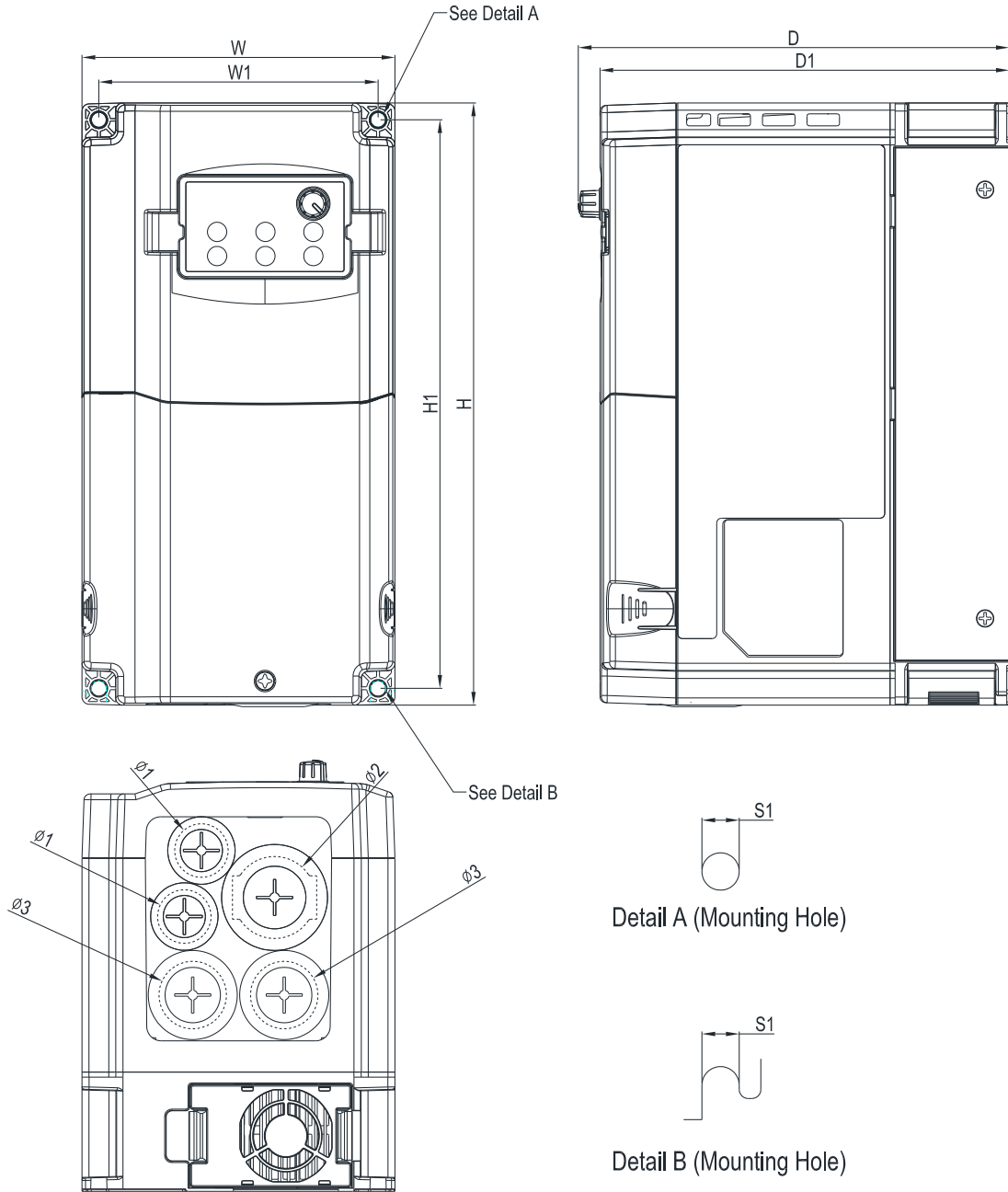

MODEL

VFD040CB43A-21M
 VFD055CB43A-21M
 VFD075CB43A-21M

Frame		W	H	D	W1	H1	D1	S1	Ø1	Ø2	Ø3
A	mm	130.0	250.0	179.0	116.0	236.0	170.0	6.2	22.2	34.0	28.0
	inch	5.12	9.84	7.05	4.57	9.29	6.69	0.24	0.87	1.34	1.10



Attention

Standard Motors

Used with 400V Standard Motors

- It is recommended to add an AC output reactor when using with a 400V standard motor to prevent damage to motor insulation.

Torque Characteristics and Temperature Rise

- When a standard motor is drive controlled, the motor temperature will be higher than with DOL operation.
- Please reduce the motor output torque when operating at low speeds to compensate for less cooling efficiency.
- For continuous constant torque at low speeds, external forced motor cooling is recommended.

Vibration

- When the motor drives the machine, resonances may occur, including machine resonances.
- Abnormal vibration may occur when operating a 2-pole motor at 60Hz or higher.

Noise

- When a standard motor is drive controlled, the motor noise will be higher than with DOL operation.
- To lower the noise, please increase the carrier frequency of the drive. The motor fan can be very noisy when the motor speed exceeds 60Hz.

Special Motors

High-speed Motor

- To ensure safety, please try the frequency setting with another motor before operating the high-speed motor at 120Hz or higher.

Explosion-proof Motor

- Please use a motor and drive that comply with explosion-proof requirements.

Submersible Motor & Pump

- The rated current is higher than that of a standard motor.
- Please check before operation and select the capacity of the AC motor drive carefully.
- The motor temperature characteristics differ from a standard motor, please set the motor thermal time constant to a lower value.

Brake Motor

- When the motor is equipped with a mechanical brake, the brake should be powered by the mains supply.
- Damage may occur when the brake is powered by the drive output. Please DO NOT drive the motor with the brake engaged.

Gear Motor

- In gearboxes or reduction gears, lubrication may be reduced if the motor is continuously operated at low speeds.
- Please DO NOT operate in this way.

Synchronous Motor

- These motors need suitable software to control them. Please contact Delta for more information.

Single-phase Motor

- Single-phase motors are not suitable for being operated by an AC Motor Drive. Please use a 3-phase motor instead when necessary.

Environmental Conditions

Installation Position

- The drive is suitable for installation in a place with ambient temperature from -10 to 50°C.
- The surface temperature of the drive and brake resistor will rise under specific operation conditions. Therefore, please install the drive on materials that are noncombustible.
- Ensure that the installation site complies with the ambient conditions as stated in the manual.

Wiring

Limit of Wiring Distance

- For remote operation, please use twist-shielding cable and the distance between the drive and control box should be less than 20m.

Maximum Motor Cable Length

- Motor cables that are too long may cause overheating of the drive or current peaks due to stray capacitance.
- Please ensure that the motor cable is less than 30m.
- If the cable length can't be reduced, please lower the carrier frequency or use an AC reactor.

Choose the Right Cable

- Please refer to current value to choose the right cable section with enough capacity or use recommended cables.

Grounding

- Please ground the drive completely by using the grounding terminal.

How to Choose the Drive Capacity

Standard Motor

- Please select the drive according to applicable motor rated current listed in the drive specification.
- Please select the next higher power AC drive in case higher starting torque or quick acceleration/deceleration is needed.

Special Motor

- Please select the drive according to: Rated current of the drive > rated current of the motor

Transportation and Storage

- Please transport and store the drive in a place that meets environment specifications.

Peripheral Equipment

Molded-Case Circuit Breakers (MCCB)

- Please install the recommended MCCB or ELCB in the main circuit of the drive and make sure that the capacity of the breaker is equal to or lower than the recommended one.

Add a Magnetic Contactor(MC) in the Output Circuit

- When a MC is installed in the output circuit of the drive to switch the motor to commercial power or other purposes, please make sure that the drive and motor are completely stopped and remove the surge absorbers from the MC before switching it.

Add a Magnetic Contactor (MC) in the Input Circuit

- Please only switch the MC ONCE per hour or it may damage the drive. Please use RUN/STOP signal to switch many times during motor operation.

Motor Protection

- The thermal protection function of the drive can be used to protect the motor by setting the operation level and motor type (standard motor or variable motor).
- When using a high-speed motor or a water-cooled motor the thermal time constant should be set to a lower value.

- When using a longer cable to connect the motor thermal relay to a motor, high-frequency currents may enter via the stray capacitance.
- It may result in malfunctioning of the relay as the real current is lower than the setting of thermal relay. Under this condition, please lower the carrier frequency or add an AC reactor to solve this.

DO NOT Use Capacitors to Improve the Power Factor

- Use a DC reactor to improve the power factor of the drive. Please DO NOT install power factor correction capacitors on the main circuit of the drive to prevent motor faults due to over current.

Do NOT Use Surge Absorber

- Please DO NOT install surge absorbers on the output circuit of the drive.

Lower the Noise

- To ensure compliance with EMC regulations, usually a filter and shielded wiring is used to lower the noise.

Method Used to Reduce the Surge Current

- Surge currents may occur in the phase-lead capacitor of the power system, causing an overvoltage when the drive is stopped or at low loads.
- It is recommended to add a DC reactor to the drive.



IABU Headquarters

Delta Electronics, Inc.

Taoyuan Technology Center
No.18, Xinglong Rd., Taoyuan City,
Taoyuan County 33068, Taiwan
TEL: 886-3-362-6301 / FAX: 886-3-371-6301

Asia

Delta Electronics (Jiangsu) Ltd.

Wujiang Plant 3
1688 Jiangxing East Road,
Wujiang Economic Development Zone
Wujiang City, Jiang Su Province,
People's Republic of China (Post code: 215200)
TEL: 86-512-6340-3008 / FAX: 86-769-6340-7290

Delta Greentech (China) Co., Ltd.

238 Min-Xia Road, Pudong District,
ShangHai, P.R.C.
Post code : 201209
TEL: 86-21-58635678 / FAX: 86-21-58630003

Delta Electronics (Japan), Inc.

Tokyo Office
2-1-14 Minato-ku Shibadaimon,
Tokyo 105-0012, Japan
TEL: 81-3-5733-1111 / FAX: 81-3-5733-1211

Delta Electronics (Korea), Inc.

1511, Byucksan Digital Valley 6-cha, Gasan-dong,
Geumcheon-gu, Seoul, Korea, 153-704
TEL: 82-2-515-5303 / FAX: 82-2-515-5302

Delta Electronics Int'l (S) Pte Ltd

4 Kaki Bukit Ave 1, #05-05, Singapore 417939
TEL: 65-6747-5155 / FAX: 65-6744-9228

Delta Electronics (India) Pvt. Ltd.

Plot No 43 Sector 35, HSIIDC
Gurgaon, PIN 122001, Haryana, India
TEL : 91-124-4874900 / FAX : 91-124-4874945

Americas

Delta Products Corporation (USA)

Raleigh Office
P.O. Box 12173, 5101 Davis Drive,
Research Triangle Park, NC 27709, U.S.A.
TEL: 1-919-767-3800 / FAX: 1-919-767-8080

Delta Greentech (Brasil) S.A

Sao Paulo Office
Rua Itapeva, 26 - 3° andar Edificio Itapeva One-Bela Vista
01332-000-São Paulo-SP-Brazil
TEL: +55 11 3568-3855 / FAX: +55 11 3568-3865

Europe

Deltronics (The Netherlands) B.V.

Eindhoven Office
De Witbogt 15, 5652 AG Eindhoven, The Netherlands
TEL: 31-40-2592850 / FAX: 31-40-2592851

*We reserve the right to change the information in this catalogue without prior notice.