

Highways

Product Range

*"Brand new solutions
for tomorrow's world"*





Passive safety

Leafield Environmental is an active member of the Passive Revolution and produces highway products that are passively safe and tested to BS12767 Passive Safety of Non Harmful Structures.

Sustainability

Our products are principally manufactured using Medium Density Polyethylene (MDPE) which is 100% recyclable at the end of the product in-service life. In addition we offer a range of ECO Bollards that are produced using a 50% content of chipped plastic bottles. We are also using the highest visibility Diamond Grade, fluorescent, retro reflective materials and helping to reduce carbon emissions from street lighting.

Testing against the highest standard

Night Owl has been independently tested and passes, at 70 km/h, BS8442:2006 (14) Retro Reflective Bollards, the highest standard for Keep Left bollards.

Cost effectiveness

Using Polyethylene makes our highway products extremely durable and able to withstand tough urban environments with little or no in-service maintenance. This makes them a very cost effective choice compared with cast or steel bollards that require repainting or regular protection from rust.



With thanks to Hull City Council and Humberside Fire and Rescue.

Range and choice

This brochure showcases our extensive range of highway bollards and winter maintenance products in a wide choice of formats and finishes. In addition we are pleased to discuss specific 'personalisation', (logos, messages etc) that may be required.

Working with you

We work with you our customers and with other manufacturers to produce total highway solutions. See the video and case study from Hull where we worked with Streetscene Engineers and the Humberside Fire and Rescue Service. Also look at the use of Night Owl on composite Traffic Islands produced by Rediwell.

Call 01189 404717 to find out more

Contents

Signs & Sign Bollards

Night Owl

4 – 5

Linsign 300

6 – 7

Linsign 230

8 – 9



Roadside Storage Bins/ Sentry Sign & Barrier

Roadside Storage Bins/Sentry Signs

10 – 11



Bollard Product Selector

12– 13

Bollard Product Selector

Choice of Material

Standard

Chastity Discriminator (CD)

10 | Lislefield | 01189 404717

Bollards

Heritage

14 – 15

Regency & Woburn

16 – 17

Sentinel

18 – 19

Monarch, Sterling & Edgeminder

20 – 21

Vergemarker

22 – 23



Colours

Colour chart

23

Nightowl

Setting a new standard*
for Self Righting Bollards.



Sign Suggestions Highway Use

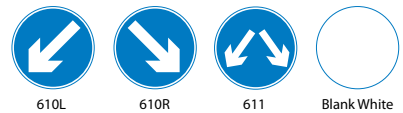

Non Highway Use



For further sign options please contact
Customer Services, telephone
01189 404717 .



Night Owl™ is an all plastic, recyclable, passively safe, self righting 'Keep Left' bollard comprising a 'bounce back' base unit and replaceable rigid sign carrier.

Night Owl has passed BS8442:2006, 'Retro Reflective Self Righting Bollards' which requires products to remain intact, returning to an upright position after a 70 km/h impact without reducing the speed of the vehicle by more than 3km/h.

Night Owl has particular application as a Keep Left bollard providing a durable, low maintenance cost, reduced carbon footprint solution for traffic islands in general.

See the Night Owl brochure for detailed information.

Night Owl is a Trademark of Leaffield Environmental Ltd



Night Owl



PASSIVE



REFLEX



BS 8442

Choose from

Single Sided
Double Sided

Fixing Options

Surface Mounted
Concrete Anchor (used in the MIRA Test)
Adapter Plates for existing fixings

Colours (see page 23)

Black, white & grey for Highways use
Standard & Premium (for non Highways use)

Sign Options

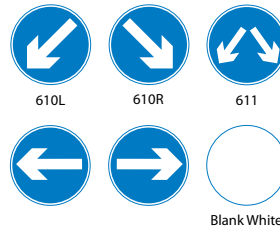

Single Sided, Sign & Panel
Double Sided, 2 signs & 1 Panel
Double Sided 1 sign & 2 Panels
Double Sided 2 Signs & 2 Panels

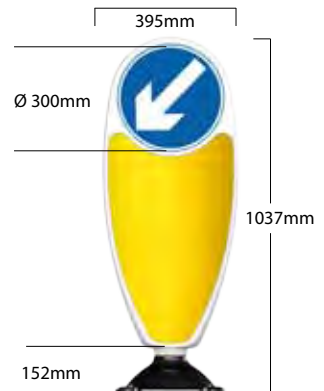

Specification

Side reflector: 53.5mm wide
Weight: 6kg
Material: MDPE

All dimensions and weights are nominal

**Night Owl has passed BS8442:2006 (14) Retro Reflective Self Righting Bollards*



Bounce Back Base



PASSIVE



REFLEX



BS 8442

Fixing Options

Surface Mounted
Concrete Anchor (used in the MIRA Test)
Adapter Plates for existing installations

Colours (see page 23)

Black



Fixing Options

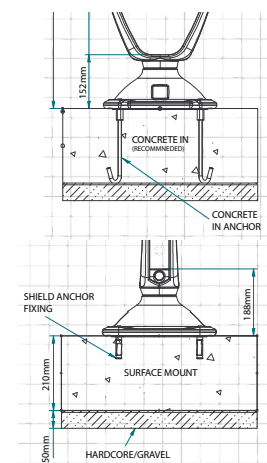

Specification

Ground fixing centres: 228 x 228mm
Weight: 1.6kg
Material: Reflex PE

All dimensions and weights are nominal



Linsign 300
Traffic bollard and low level sign...
for a wide range of applications.

Sign Suggestions

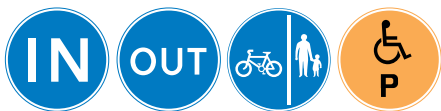
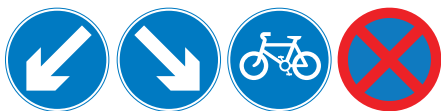

Sign
profile

Double Single



For further sign options please contact Customer Services,
telephone 01189 404717 .

Sentinel Linsign 300 Visibol

Choose from

Sentinel Linsign 300 Visibol Standard or ECO
Single Sided Sign profile
or Double Sided Sign profile (see left)

Fixing Options*

Sentinel Linsign 300 Visibol Standard All
Sentinel Linsign 300 Visibol ECO PM, AR & S

Colours (see page 23)

Standard & Premium
ECO

Banding

Choice of Class ref 1 & Class ref 2 British
Standard Reflective banding available.
Aluminium backed for vandal resistance.
See page 13.

Banding Ideas



Left to right:

Light Grey: Blue Reflective Band
Black: All Yellow Reflective Band
Black: Yellow Reflective Band
Sandstone: Red/White Reflective Band

*PM - Permanent, AR - Anti-Ram, S - Socketed, SM - Surface



Heritage Linsign 300

✓ ECO ✓ Class ref 1&2

Choose from

Heritage Linsign 300 Standard or ECO
Single Sided Sign profile
or Double Sided Sign profile (see page 6)

Fixing Options*

Heritage Linsign 300 Standard All
Heritage Linsign 300 ECO PM, AR & S

Colours (see page 23)

Standard & Premium
ECO

Banding

Choice of Class ref 1 & Class ref 2 British
Standard Reflective banding available.
Aluminium backed for vandal resistance.
Decorative banding is optional see page 13.

*PM - Permanent, AR - Anti-Ram, S - Socketed, SM - Surface

Banding Ideas



Left to right:

Light Grey: White Reflective Band,
Blue Decorative Band
Sandstone: Red/White Reflective Band
Black: Yellow Reflective Band



Specification

Weight: Less than 7kg
Material: MDPE

All dimensions and weights are nominal

Heritage Linsign 300 Visibol

✓ ECO ✓ Class ref 1&2

Choose from

Heritage Linsign 300 Visibol Standard or ECO
Single Sided Sign profile
or Double Sided Sign profile (see page 6)

Fixing Options*

Heritage Linsign 300 Visibol Standard All
Heritage Linsign 300 Visibol ECO PM, AR & S

Colours (see page 23)

Standard & Premium
ECO

Banding

Choice of Class ref 1 & Class ref 2 British
Standard Reflective banding available.
Aluminium backed for vandal resistance.
Decorative banding is optional see page 13.

*PM - Permanent, AR - Anti-Ram, S - Socketed, SM - Surface

Banding Ideas



Left to right:

Black: Blue Reflective Band,
Blue Decorative Band
Black: All Yellow Reflective
& Decorative Band
Black: Yellow Reflective Band
Sandstone: Red/White Reflective Band

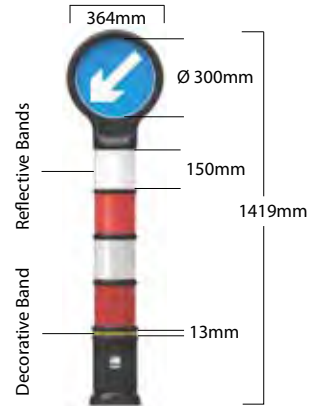

Specification

Weight: Less than 7kg
Material: MDPE

All dimensions and weights are nominal

Sentinel Linsign 300

✓ ECO ✓ Class ref 1&2

Choose from

Sentinel Linsign 300 Standard or ECO
Single Sided Sign profile
or Double Sided Sign profile (see page 6)

Fixing Options*

Sentinel Linsign 300 Standard All
Sentinel Linsign 300 ECO PM, AR & S

Colours (see page 23)

Standard & Premium
ECO

Banding

Choice of Class ref 1 & Class ref 2 British
Standard Reflective banding available.
Aluminium backed for vandal resistance.
See page 13.

*PM - Permanent, AR - Anti-Ram, S - Socketed, SM - Surface

Banding Ideas



Left to right:

Light Grey: White Reflective Band
Sandstone: Red/White Reflective Band
Black: Yellow Reflective Band



Specification

Weight: Less than 7kg
Material: MDPE

All dimensions and weights are nominal

✓ ECO ✓ Class ref 1&2



Specification

Weight: Less than 7kg
Material: MDPE

All dimensions and weights are nominal

Linsign 230

Traffic bollard and low level sign...
ideal for parking control applications.



Sign Suggestions



Sign profiles

Double Single



For further sign options please contact Customer Services, telephone 01189 404717.

Sentinel Linsign 230 Visibol

Choose from

Sentinel Linsign 230 Visibol Standard or ECO
Single Sided Sign profile
or Double Sided Sign profile (see left)

Fixing Options*

Sentinel Linsign 230 Visibol Standard All
Sentinel Linsign 230 Visibol ECO PM, AR & S

Colours (see age 23)

Standard & Premium
ECO

Banding

Choice of Class ref 1 & Class ref 2 British
Standard Reflective banding available.
Aluminium backed for vandal resistance.
See page 13.

Banding Ideas



Left to right:

Light Grey: Blue Reflective Band
Black: Yellow Reflective Bands
Black: All Yellow Reflective Bands
Sandstone: Red/White Reflective Band

*PM - Permanent, AR - Anti-Ram, S - Socketed, SM - Surface



Heritage Linsign 230

✓ ECO ✓ Class ref 1&2

Choose from

Heritage Linsign 230 Standard or ECO
Single Sided Sign profile
or Double Sided Sign profile (see page 8)

Fixing Options*

Heritage Linsign 230 Standard All
Heritage Linsign 230 ECO PM, AR & S

Colours (see page 23)

Standard & Premium
ECO

Banding

Choice of Class ref 1 & Class ref 2 British
Standard Reflective banding available.
Aluminium backed for vandal resistance.
Decorative banding is optional see page 13.

Banding Ideas



Left to right:

Light Grey: White Reflective Band,
Blue Decorative Band
Sandstone: Red/White Reflective Band
Black: Yellow Reflective Band

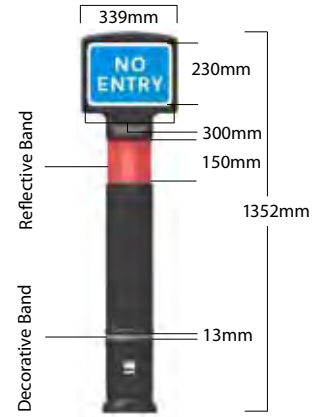

Specification

Weight: Less than 7kg
Material: MDPE

All dimensions and weights are nominal

*PM - Permanent, AR - Anti-Ram, S - Socketed, SM - Surface



Heritage Linsign 230 Visibol

✓ ECO ✓ Class ref 1&2

Choose from

Heritage Linsign 230 Visibol Standard or ECO
Single Sided Sign profile
or Double Sided Sign profile (see page 8)

Fixing Options*

Heritage Linsign 230 Visibol Standard All
Heritage Linsign 230 Visibol ECO PM, AR & S

Colours (see page 23)

Standard & Premium
ECO

Banding

Choice of Class ref 1 & Class ref 2 British
Standard Reflective banding available.
Aluminium backed for vandal resistance.
Decorative banding is optional see page 13.

Banding Ideas



Left to right:

Light Grey: Blue Reflective Band,
Blue Decorative Band
Black: Yellow Reflective Band
Black: All Yellow Reflective
& Decorative Band
Sandstone: Red/White Reflective Band

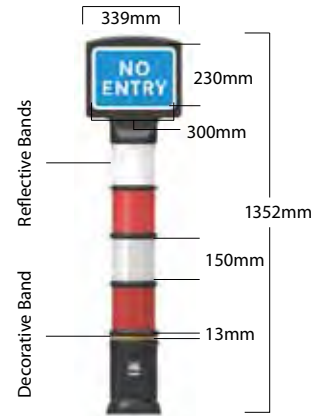

Specification

Weight: Less than 7kg
Material: MDPE

All dimensions and weights are nominal

*PM - Permanent, AR - Anti-Ram, S - Socketed, SM - Surface

✓ ECO ✓ Class ref 1&2

Sentinel Linsign 230

✓ ECO ✓ Class ref 1&2

Choose from

Sentinel Linsign 230 Standard or ECO
Single Sided Sign profile
or Double Sided Sign profile (see page 8)

Fixing Options*

Sentinel Linsign 230 Standard All
Sentinel Linsign 230 ECO PM, AR & S

Colours (see page 23)

Standard & Premium
ECO

Banding

Choice of Class ref 1 & Class ref 2 British
Standard Reflective banding available.
Aluminium backed for vandal resistance.
See page 13.

Banding Ideas



Left to right:

Light Grey: Blue Reflective Band
Sandstone: Red/White Reflective Band
Black: Yellow Reflective Band

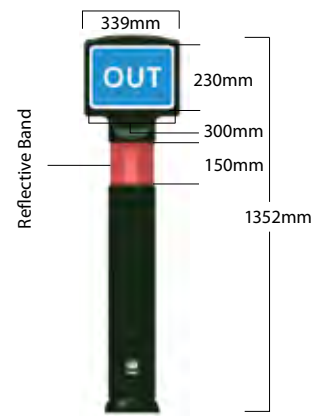

Specification

Weight: Less than 7kg
Material: MDPE

All dimensions and weights are nominal

*PM - Permanent, AR - Anti-Ram, S - Socketed, SM - Surface

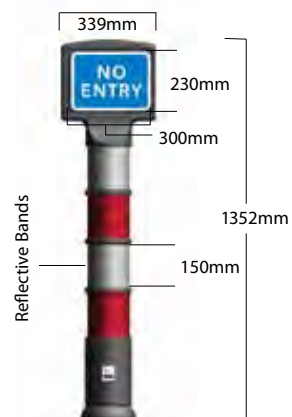

Specification

Weight: Less than 7kg
Material: MDPE

All dimensions and weights are nominal

Roadside Storage Bins & Sentry Sign

Ideal for a wide range of situations and applications



Above: Grit Bins used in car parks for staff and customer safety.

Left: Grit Bins can be produced in a range of colours and with personalisation.

Right: In storage 200 litre Grit Bins can be stacked five high.

Far right: Sentry Signs provide robust and useful advisory signage for garage forecourts.





Salt & Grit Bins

- Double skin perimeter lid for greater rigidity
- Robust rib structure for added strength
- Wear resistant base
- 200 litre units nest up to five high, 400 litre units nest up to four high (180 degree, 60% nest for a stable stack)
- Fork lift space for easy manoeuvrability

Capacity

200 & 400 litre capacity

Optional

- Hasp and Staple
- Gold Banding
- Personalisation

Colours (see page 23)

Standard & Premium

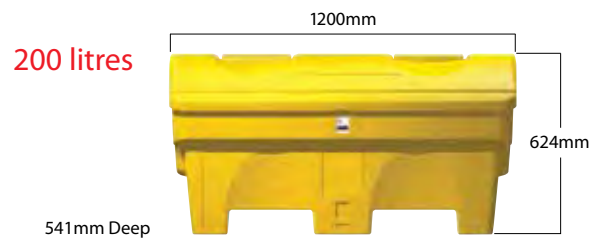

All dimensions are nominal

Sentry Sign & Barrier

- Temporary vehicular and pedestrian warning sign
- Use in multiples to form barriers
- Stackable, practical for large events
- Robust, durable & impact resistant
- Weather resistant
- Choice of screw fixings or channel for slot-in graphic board*

*Not included

Colours (see page 23)

Standard & Premium

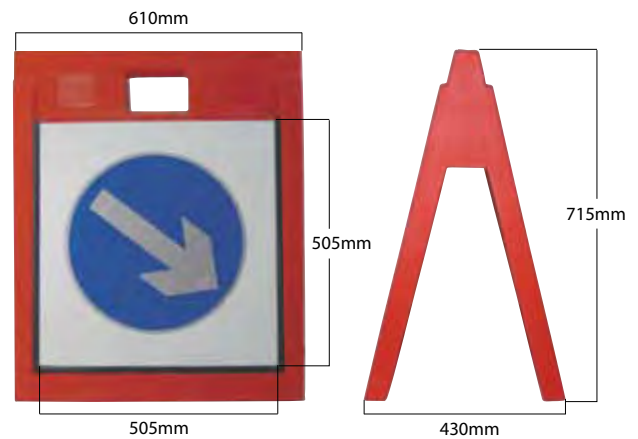

Specification

Weight: 7 kg

Material: MDPE

All dimensions and weights are nominal



Bollard Product Selector

Scale

1 metre

This is a summary, please refer to the product pages for full details on all options available.

		HERITAGE			SENTINEL			WOBURN		REGENCY		EDGE MINDER	MONARCH	STERLING	VERGEMARKER	
Version		150	150	Deco	150	150	Deco	150	75	150	Deco					Heritage
Type			Visibol			Visibol										
Dimensions (mm)	Height	1024	1024	921	1030	1030	926	1084	1009	1030	910	510	800	800	938	1419
	Diameter	171	171	171	166	166	166	185	185	166	166	130	170	170	125	364
Material Options	Standard	✓	✓	✓	✓	✓	✓	✓	✓	✓	✓	✓	✓	✓	-	✓
	Reflex	✓	-	✓	✓	-	✓	✓	✓	✓	✓	✓	✓	✓	✓	-
	ECO	✓	✓	✓	✓	✓	✓	-	-	-	-	✓	-	-	-	✓
Fixing Options	PM Permanent	✓	✓	✓	✓	✓	✓	✓	✓	✓	✓	✓	✓	✓	✓	✓
	S Socketed	✓	✓	✓	✓	✓	✓	✓	✓	✓	✓	-	-	-	-	✓
	AR Anti-ram	✓	✓	✓	✓	✓	✓	✓	✓	✓	✓	-	-	✓	✓	✓
	SM Surface	✓	✓	✓	✓	✓	✓	✓	✓	✓	✓	-	-	-	-	✓
Banding Options	Class ref 1	✓	✓	-	✓	✓	-	✓	✓	✓	-	✓	✓	-	-	✓
	Class ref 2	✓	✓	-	✓	✓	-	✓	✓	✓	-	✓	-	-	✓	✓
	Decorative	✓	✓	✓	-	-	✓	-	-	-	✓	✓	-	-	-	✓
DDA Compliant		✓	✓	-	✓	✓	-	✓	-	✓	-	-	-	-	-	-
Page		14	14	14	18	18	18	17	16	17	17	21	21	21	22	7

Fixing Options

Permanent Fixing (PM)

For permanent fixing the bollard base is concreted in below ground. The bollard is supplied as a single unit with a moulded-in anchor section that is set into the concrete ensuring that the bollard cannot be removed.



Anti-Ram Fixing (AR)

The bollard is supplied as a 'sleeve' that sits over a robust steel tube core that is permanently concreted into the ground. Effective as a deterrent only to 'ram raiding' (not PAS 68 classified) and also enhances pedestrian safety within high risk areas.



Socketed Fixing (S)

This two piece system allows the bollard to be quickly removed to allow immediate access or replacement. The bollard comes with a moulded-in 'bayonet' end that fixes (by rotating through 90 degrees) into a lockable base unit that has been set in concrete below ground level. A blanking cap is available for when the bollard is removed. Where reflex material is specified the product is only suitable for very low speed impacts.



Surface Fixing (SM)

The bollard is supplied with an integral circular base with four bolt holes for quick and easy fixing onto a suitable concrete base. Ideal in a wide range of situations and particularly suitable for multi-storey car parks, bridges and any situation where below ground services or membranes might be vulnerable. Where reflex material is specified the product is only suitable for very low speed impacts.



LINSIGN 300	LINSIGN 230
-------------	-------------



Heritage	Sentinel	Sentinel	Heritage	Heritage	Sentinel	Sentinel
Visibol		Visibol		Visibol		Visibol
1419	1419	1419	1352	1352	1352	1352
364	364	364	339	339	339	339
✓	✓	✓	✓	✓	✓	✓
-	-	-	-	-	-	-
✓	✓	✓	✓	✓	✓	✓
✓	✓	✓	✓	✓	✓	✓
✓	✓	✓	✓	✓	✓	✓
✓	✓	✓	✓	✓	✓	✓
✓	✓	✓	✓	✓	✓	✓
✓	✓	✓	✓	✓	✓	✓
✓	✓	✓	✓	✓	✓	✓
✓	✓	✓	✓	✓	✓	✓
✓	-	-	✓	✓	-	-
-	-	-	-	-	-	-
6	7	7	9	9	9	8

Reflective & Decorative Banding

Aluminium backed British Standard Reflective Banding (BS EN 12899-1 2001)

Class ref 1 Engineering Grade

Applications: Non Highway traffic signs, emblems, street name plates and other general signage.

Benefits: Provides good level of reflective performance, appearing both bright and legible in daylight and at night. 7 year effective performance life.



Class ref 2 High Intensity

Applications: Highway traffic safety applications where night time visibility is paramount.

Benefits: Provides high level of reflective performance. Class 2 material is approximately 3.5 times brighter than Class 1 material and provides a 10 year effective performance life.



Decorative Banding

Gold and Silver metallic decorative banding is available as a standard optional extra to add a stylish and traditional look particularly in heritage or prestige environments. If there is a special requirement to use coloured or reflective material on the decorative band this may also be possible by quotation subject to quantities and lead times.



Choice of Material

Reflex (Self Righting)

Reflex bollards are manufactured from a tough and durable material, which enables the products to withstand impact from any direction and return to an upright position and continue in service. Specify Reflex material for vulnerable locations where conventional bollards would otherwise require frequent replacement.



Where reflex material is specified with either a Socketed or Surface Fixing the product is only suitable for very low speed impacts.

ECO

ECO bollards are manufactured using a combination of 50% chipped plastic bottles and 50% regular polymer. Using chipped material reduces the environmental impact of re-processing to the absolute minimum. ECO bollards are available in black or an attractive stone effect finish which, due to the nature of the material, will vary slightly.



Standard

Standard Moulded Polyethylene (PE) is extremely durable with outstanding impact, fracture and shatter resistance properties tested to BS2782. PE is also 100% recyclable allowing the material to be reused at the end of the bollard in-service life.

Disability Discrimination Act (DDA)

The DDA seeks to ensure that public spaces and buildings are accessible to all. Bollards are an important safety feature of urban landscapes and the principles of the DDA apply in their design and use. We have an extensive range of products that comply with these requirements and for convenience these are indicated accordingly.



Heritage

Traditional style... choice of options...
suitable for urban and rural environments.

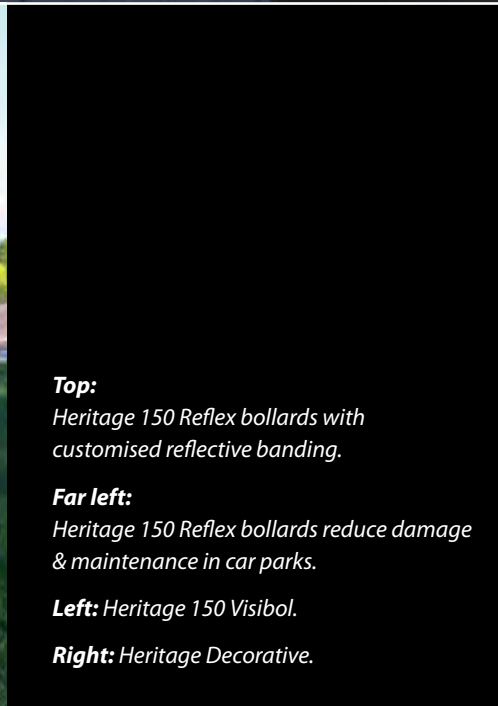

Top:
*Heritage 150 Reflex bollards with
customised reflective banding.*

Far left:
*Heritage 150 Reflex bollards reduce damage
& maintenance in car parks.*

Left: *Heritage 150 Visibol.*

Right: *Heritage Decorative.*



Heritage 150

✓ DDA
 ✓ ECO
 ✓ REFLEX
 ✓ Class ref 1&2

Choose from

Heritage 150 Standard
 Heritage 150 Reflex
 Heritage 150 ECO

Fixing Options*

Heritage 150 Standard All
 Heritage 150 Reflex PM, S & SM
 Heritage 150 ECO PM, AR & S

Colours (see page 23)

Standard & Premium
 Reflex or ECO

Banding

Choice of Class ref 1 & Class ref 2 British
 Standard Reflective banding available.
 Aluminium backed for vandal resistance.
 Decorative banding is optional see page 13.

*PM - Permanent, AR - Anti-Ram, S - Socketed, SM - Surface

Banding Ideas



Left to right:
Light Grey: Blue Reflective Band, Blue Decorative Band
Burgundy: Yellow Reflective Band
Racing Green: Yellow Reflective Band, Gold Decorative Band
Sandstone: Red/White Reflective Band

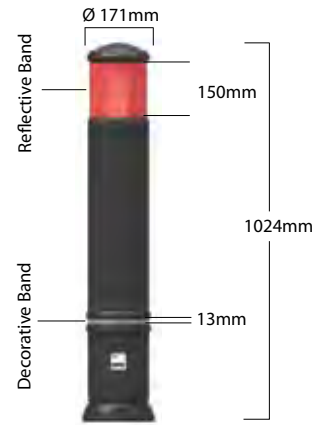

Specification

Weight: Less than 7kg
 Material: MDPE
 All dimensions and weights are nominal



Heritage 150 Visibol

✓ DDA
 ✓ ECO
 ✓ Class ref 1&2

Choose from

Heritage 150 Visibol Standard
 Heritage 150 Visibol ECO

Fixing Options*

Heritage 150 Visibol Standard All
 Heritage 150 Visibol ECO PM, AR & S

Colours (see page 23)

Standard & Premium
 ECO

Banding

Choice of Class ref 1 & Class ref 2 British
 Standard Reflective banding available.
 Aluminium backed for vandal resistance.
 Decorative banding is optional see page 13.

*PM - Permanent, AR - Anti-Ram, S - Socketed, SM - Surface

Banding Ideas



Left to right:
Light Grey: Blue Cycle Reflective Band, Blue Decorative Band
Black: Yellow Reflective Band
Black: All Yellow Reflective & Decorative Band
Sandstone: Red/White Reflective Band

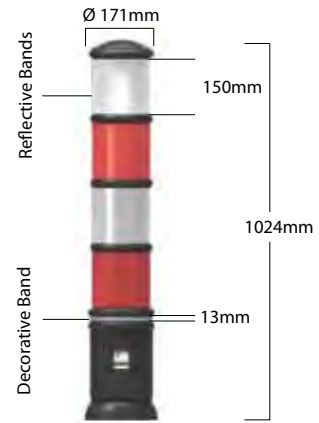

Specification

Weight: Less than 7kg
 Material: MDPE
 All dimensions and weights are nominal

Heritage Decorative

✓ ECO
 ✓ REFLEX

Choose from

Heritage Decorative Standard
 Heritage Decorative Reflex
 Heritage Decorative ECO

Fixing Options*

Heritage Decorative Standard All
 Heritage Decorative Reflex PM & SM
 Heritage Decorative ECO PM, AR & S

Colours (see page 23)

Standard & Premium
 Reflex
 ECO

Banding

Choice of Decorative banding available.
 See page 13.

*PM - Permanent, AR - Anti-Ram, S - Socketed, SM - Surface

Banding Ideas



Left to right:
Light Grey: Blue Decorative Band
Burgundy: Gold Decorative Band
Racing Green: Gold Decorative Band
Sandstone: Red Reflective Band

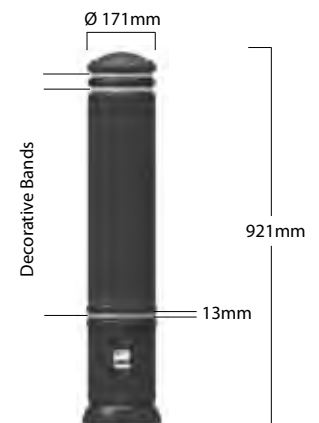

Specification

Weight: Less than 6kg
 Material: MDPE
 All dimensions and weights are nominal

Regency & Woburn

Traditional profiles... modern material... practical choice.

CASTLE COMBE
GIDDEA HALL
SLAUGHTERFORD
BATH
CORSHAM



Woburn 75 bollards with reflective banding



Regency Decorative bollard

Woburn 75

Choose from

Woburn 75 Standard
Woburn 75 Reflex

Fixing Options*

Woburn 75 Standard
Woburn 75 Reflex

All
PM & SM

Colours (see page 23)

Standard & Premium
Reflex

Branding

Choice of Class ref 1 & Class ref 2 British
Standard Reflective banding available.
Aluminium backed for vandal resistance.
See page 13.

Banding Ideas



Left to right:

Light Grey: Blue Reflective Band

Black: Yellow Reflective Band

Racing Green: Yellow Reflective Band

Sandstone: Red/White Reflective Band

*PM - Permanent, AR - Anti-Ram, S - Socketed, SM - Surface



Regency 150

✓ DDA ✓ REFLEX ✓ Class ref 1&2

Choose from
Regency 150 Standard
Regency 150 Reflex

Fixing Options*
Regency 150 Standard
Regency 150 Reflex

All
PM & SM

Colours (see page 23)
Standard & Premium
Reflex

Banding
Choice of Class ref 1 & Class ref 2 British
Standard Reflective banding available.
Aluminium backed for vandal resistance.
See page 13.

*PM - Permanent, AR - Anti-Ram, S - Socketed, SM - Surface

Banding Ideas



Left to right:
Light Grey: Blue Cycle Reflective Band
Black: Yellow Reflective Band
Burgundy: Yellow Reflective Band
Slate Mottle Grey: Red/White Reflective Band



Specification

Weight: Less than 6kg
Material: MDPE
All dimensions and weights are nominal

Regency Decorative

✓ REFLEX

Choose from
Regency Decorative Standard
Regency Decorative Reflex

Fixing Options*
Regency Decorative Standard PM, S & SM
Regency Decorative Reflex PM & SM

Colours (see page 23)
Standard & Premium
Reflex

Banding
Choice of Decorative banding available.
See page 13.

*PM - Permanent, AR - Anti-Ram, S - Socketed, SM - Surface

Banding Ideas

Metallic



Left to right:
Light Grey: Blue Decorative Band
Black: Silver Decorative Band
Burgundy: Gold Decorative Band
Slate Mottle Grey: Red Decorative Band

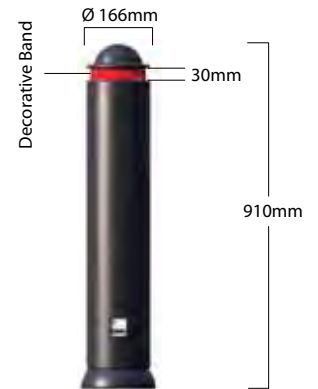

Specification

Weight: Less than 6kg
Material: MDPE
All dimensions and weights are nominal

✓ REFLEX ✓ Class ref 1&2

Woburn 150

✓ DDA ✓ REFLEX ✓ Class ref 1&2

Choose from
Woburn 150 Standard
Woburn 150 Reflex

Fixing Options*
Woburn 150 Standard
Woburn 150 Reflex

All
PM & SM

Colours (see page 23)
Standard & Premium
Reflex

Banding
Choice of Class ref 1 & Class ref 2 British
Standard Reflective banding available.
Aluminium backed for vandal resistance.
See page 13.

*PM - Permanent, AR - Anti-Ram, S - Socketed, SM - Surface

Banding Ideas



Left to right:
Light Grey: Blue Cycle Reflective Band
Burgundy: Yellow Reflective Band
Racing Green: Yellow Reflective Band
Sandstone: Red/White Reflective Band

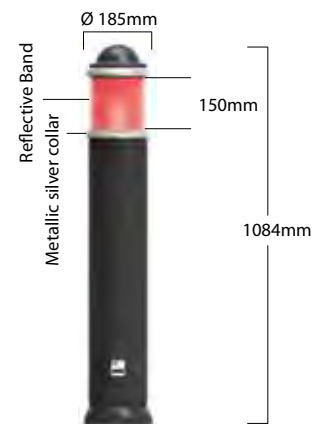

Specification

Weight: Less than 7.5kg
Material: MDPE
All dimensions and weights are nominal

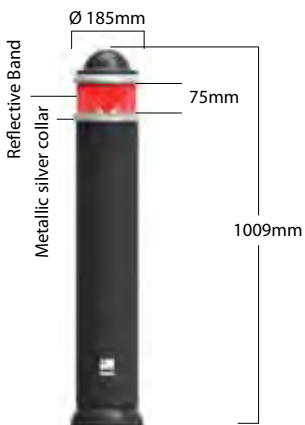

Specification

Weight: Less than 7.5kg
Material: MDPE
All dimensions and weights are nominal

Sentinel Bollards

Contemporary style... durable & practical...
ideal for urban, retail and industrial locations.

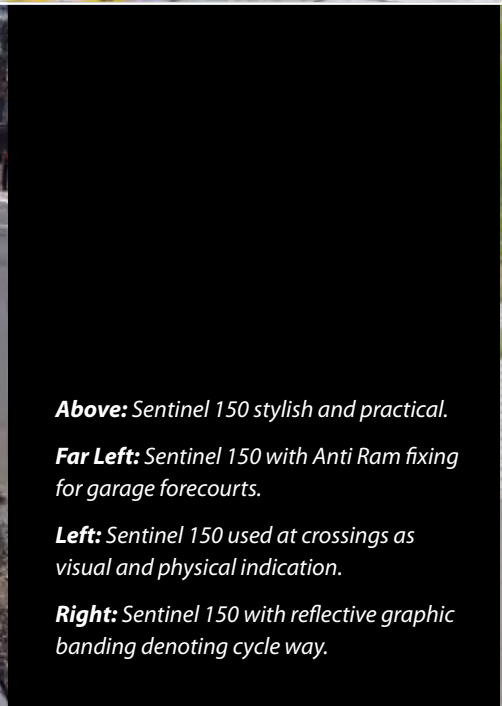
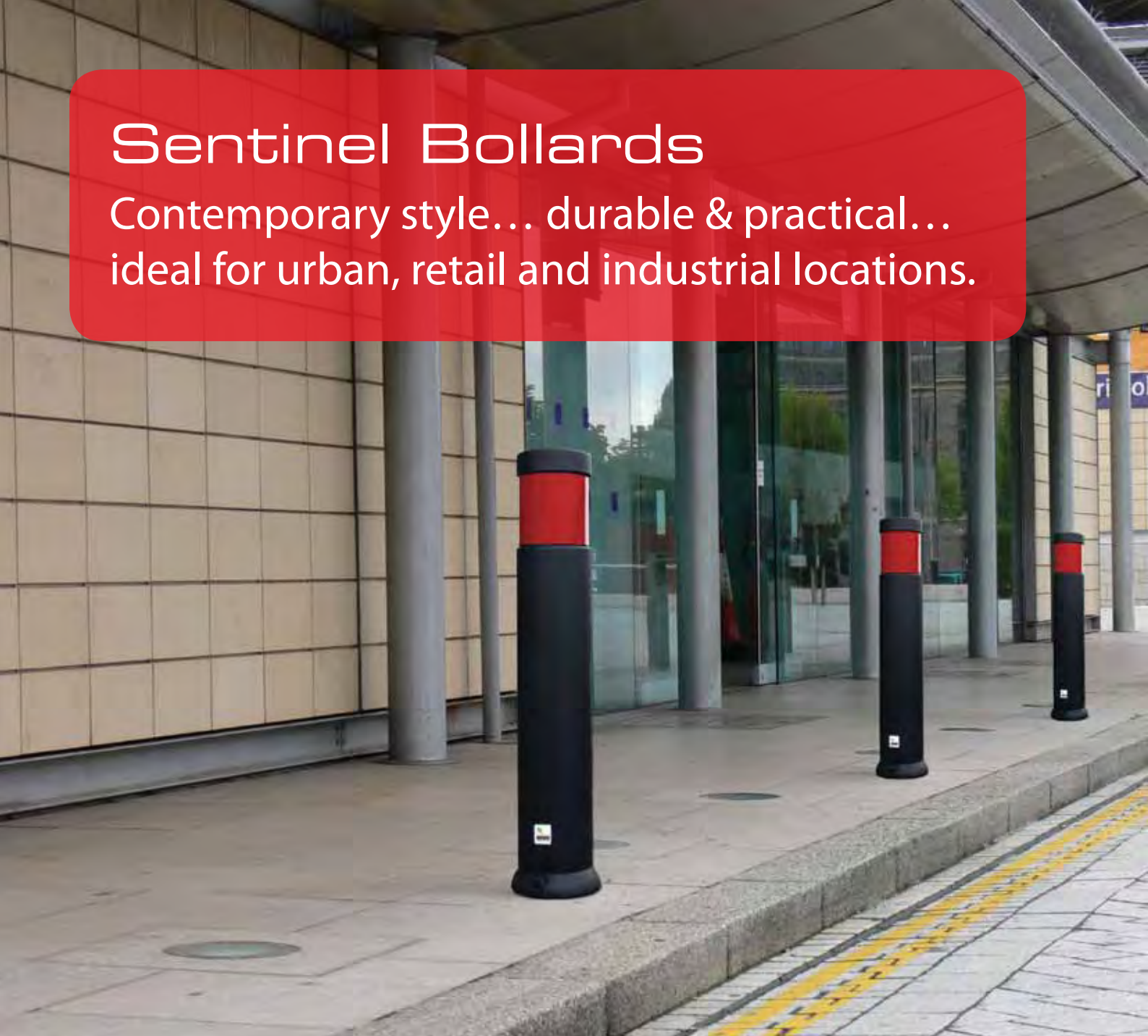

Above: Sentinel 150 stylish and practical.

Far Left: Sentinel 150 with Anti Ram fixing for garage forecourts.

Left: Sentinel 150 used at crossings as visual and physical indication.

Right: Sentinel 150 with reflective graphic banding denoting cycle way.



Sentinel 150

✓
DDA
✓
ECO
✓
REFLEX
✓
Class ref 1&2

Choose from

Sentinel 150 Standard
 Sentinel 150 Reflex
 Sentinel 150 ECO

Fixing Options*

Sentinel 150 Standard All
 Sentinel 150 Reflex PM, S, & SM
 Sentinel 150 ECO PM, AR & S

Colours (see page 23)

Standard & Premium
Reflex or ECO

Banding

Choice of Class ref 1 & Class ref 2 British
 Standard Reflective banding available.
 Aluminium backed for vandal resistance.
 See page 13.

*PM - Permanent, AR - Anti-Ram, S - Socketed, SM - Surface

Banding Ideas



Left to right:

Light Grey: Blue Cycle Reflective Band
Black: Yellow Reflective Band
Racing Green: Yellow Reflective Band
Sandstone: Red/White Reflective Band

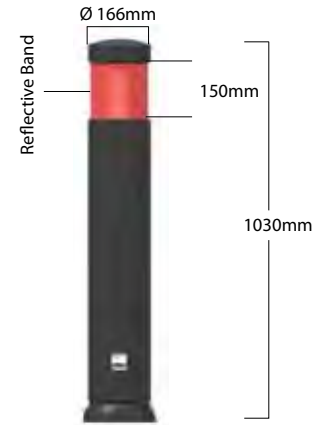

Specification

Weight: Less than 7kg
 Material: MDPE

All dimensions and weights are nominal

Sentinel 150 Visibol

✓
DDA
✓
ECO
✓
Class ref 1&2

Choose from

Sentinel 150 Visibol Standard
 Sentinel 150 Visibol ECO

Fixing Options*

Sentinel 150 Visibol Standard All
 Sentinel 150 Visibol ECO PM, AR & S

Colours (see page 23)

Standard & Premium
ECO

Banding

Choice of Class ref 1 & Class ref 2 British
 Standard Reflective banding available.
 Aluminium backed for vandal resistance.
 See page 13.

*PM - Permanent, AR - Anti-Ram, S - Socketed, SM - Surface

Banding Ideas



Left to right:

Light Grey: Blue Cycle Reflective Band
Black: All yellow Reflective Band
Black: Yellow Reflective Band
Sandstone: Red/White Reflective Band

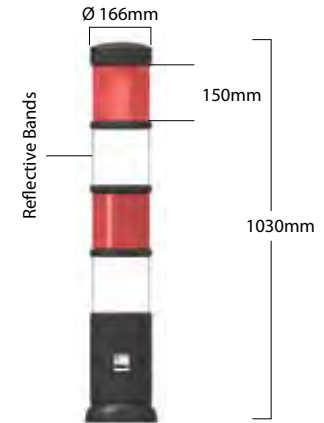

Specification

Weight: Less than 7kg
 Material: MDPE

All dimensions and weights are nominal



Sentinel Decorative

✓
ECO
✓
REFLEX

Choose from

Sentinel Decorative Standard
 Sentinel Decorative Reflex
 Sentinel Decorative ECO

Fixing Options*

Sentinel Decorative Standard All
 Sentinel Decorative Reflex PM & SM
 Sentinel Decorative ECO PM, AR & S

Colours (see page 23)

Standard & Premium
 Reflex
 ECO

Banding

Choice of Decorative banding available.
 See page 13.

*PM - Permanent, AR - Anti-Ram, S - Socketed, SM - Surface

Banding Ideas



Left to right:

Light Grey: Blue Decorative Band
Burgundy: Gold Decorative Band
Racing Green: Gold Decorative Band
Sandstone: Red Decorative Band

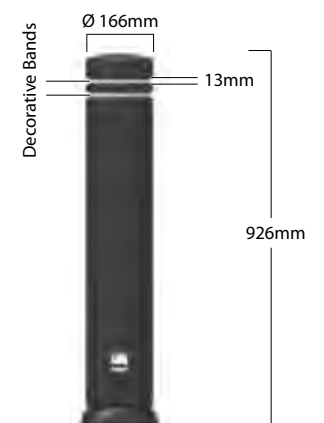

Specification

Weight: Less than 6kg
 Material: MDPE

All dimensions and weights are nominal

Bollards for Town and Country

... designs to suit a range of applications.



Above:
Edgeminder bollards used to protect grass verges.

Left: Sterling bollards used with chain link, supplied by customer.

Right: Monarch bollards used to protect an office building.



Monarch

Choose from

Monarch Standard
Monarch Reflex

Fixing Options*

Standard
Reflex

PM & AR
PM

Colours (see page 23)

Standard & Premium
Reflex

Banding

Choice of Class ref 1 British Standard
Reflective banding available. See page 13.

*PM - Permanent, AR - Anti-Ram, S - Socketed, SM - Surface

REFLEX ✓
Class ref 1 ✓

Banding Ideas



Left to right:

Pallet Orange: Red Reflective Band
Signal Red: Yellow Reflective Band
Racing Green: Yellow Reflective Band
Golden Yellow: Red Reflective Band

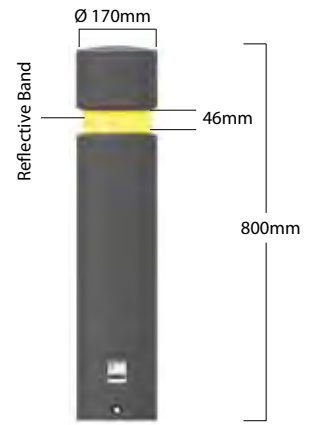

Specification

Weight: Less than 3.5kg
Material: MDPE

All dimensions and weights are nominal



Edgeminder

Choose from

Edgeminder Standard
Edgeminder Reflex
Edgeminder ECO

Fixing Options*

Standard
Reflex
ECO

PM
PM
PM

Colours (see page 23)

Standard & Premium
Reflex or ECO

Banding

Choice of Class ref 1 & Class ref 2 British
Standard Reflective banding available.
Aluminium backed for vandal resistance.
Decorative banding is optional see page 13.

*PM - Permanent, AR - Anti-Ram, S - Socketed, SM - Surface

ECO ✓
REFLEX ✓
Class ref 1&2 ✓

Banding Ideas



Left to right:

Light Grey: Blue Reflective Band
Burgundy: Gold Reflective Band
Racing Green: Silver Reflective Band
Sandstone: Red Reflective Band

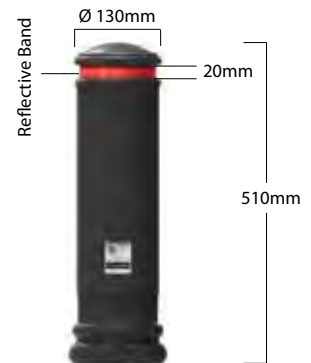

Specification

Weight: Less than 1.75kg
Material: MDPE

All dimensions and weights are nominal

Sterling

Choose from

Sterling Standard
Sterling Reflex

Fixing Options*

Standard
Reflex

PM & AR
PM

Colours (see page 23)

Standard & Premium
Reflex



REFLEX ✓

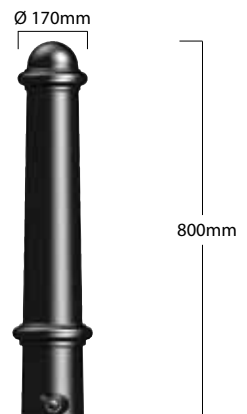

Specification

Weight: Less than 5kg
Material: MDPE

All dimensions and weights are nominal

Vergemarker

High on practicality and visibility...
low on maintenance and cost.



Colours

Leafield manufactures all its products to order, so it is often possible to match your colour scheme or other specifications.

Please call our Customer Services Team to discuss your requirements.



Vergemarkers provide a high visibility warning sign and are particularly effective in a range of high risk incident situations including deceptive bends and junctions.

Vergemarkers are manufactured as a single unit and have a moulded-in below ground section to allow for permanent fixing. They are produced in very strong reflex material and the overall product design provides low impact resistance to vehicles.

If struck by a vehicle Vergemarker is designed to fold at a specific crease point without unduly reducing the vehicle speed. Unobstructed they will self right to an upright position to continue in service.

The reflector is a Class 2 retro-reflective material on a stainless steel backing for improved adhesion and durability.

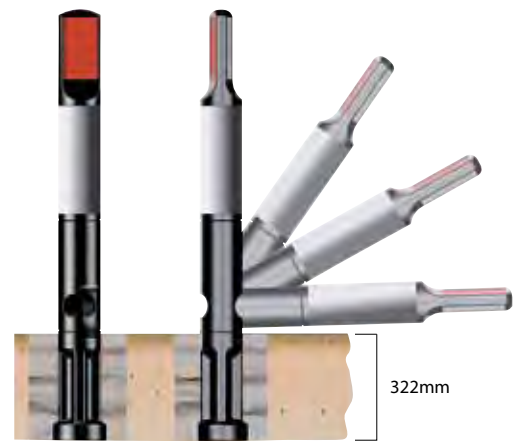

Vergemarker



- Choose from**
Reflex Vergemarker
- Fixing Options***
Reflex Vergemarker
- Colours** (see page 23)
Black
- Banding**
White band as standard.

*PM - Permanent

✓ REFLEX ✓ Class ref 2

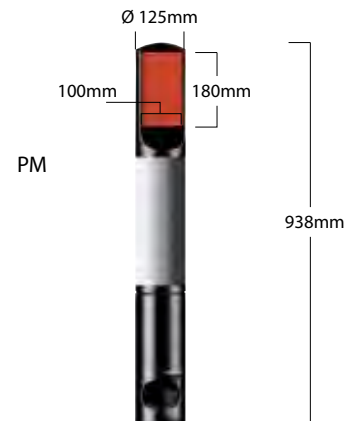

Specification

Weight: Less than 1.9kg
Material: MDPE

All dimensions and weights are nominal

Standard



Premium

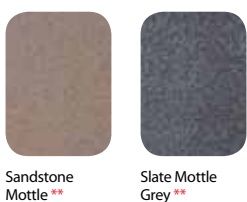

Reflex

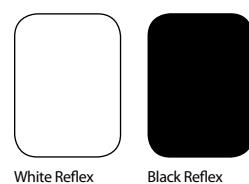

ECO



The colours reproduced in this brochure are constrained by the printing process. Colour plaques are available on request if required.

* Denotes a colour with a longer lead time
** Denotes a colour with a premium price point

About Leaffield Environmental

We are an award winning UK manufacturer and a specialist producer of solutions for the needs of the Litter, Recycling, Highways, Water, and Agricultural markets.

Our customers include the country's leading Companies, Universities and Public Sector institutions.

Environmental - ISO 14001

We are a company that cares about the environment and our business has in place Environmental Management Systems that have been certified and comply with BS EN ISO 14001:2004.

Quality & Service - ISO 9001

We have a 'quality culture' running throughout our business and have systems in place, certified to BS EN ISO 9001:2008, which ensure that our customers receive a consistently high level of quality and service.

Health & Safety

We care about the occupational Health and Safety of our staff and are an OHSAS 18001 certified employer.

Registered Designs

Vergemarker, Sentinel 150, Night Owl and Night Owl Base are the Registered Designs of Leaffield Environmental.

Sustainability

Our products are principally manufactured using Medium Density Polyethylene (MDPE) which is 100% recyclable at the end of the product in-service life. Wherever possible our products are made using a proportion of recycled material that varies according to product type and colour.

Award Winning Design

Our design team consistently produce product solutions that are independently recognised for their excellence.

2003	Best Environmental or Energy Efficiency Programme	Envirobank 140
2003	National Recycling Awards Recycled product of the year finalist	Envirobank 140
2008	Best Industrial Product Design	TwinBin
2008	Technical Innovation Award	WT Drinking Troughs
2010	Horners Award for Plastic Design & Innovation (Highly Commended Certificate)	Night Owl Keep Left Bollard

Leaffield Environmental is setting new standards in the design, manufacture and performance of a range of specialist products for the Highways market.

From the exciting new Night Owl Keep Left bollard with its high passive safety rating and our range of Reflex or 'bounce back' bollards to our ECO products that utilise recycled plastic bottles, Leaffield Environmental's innovative, solutions led approach is clearly apparent.

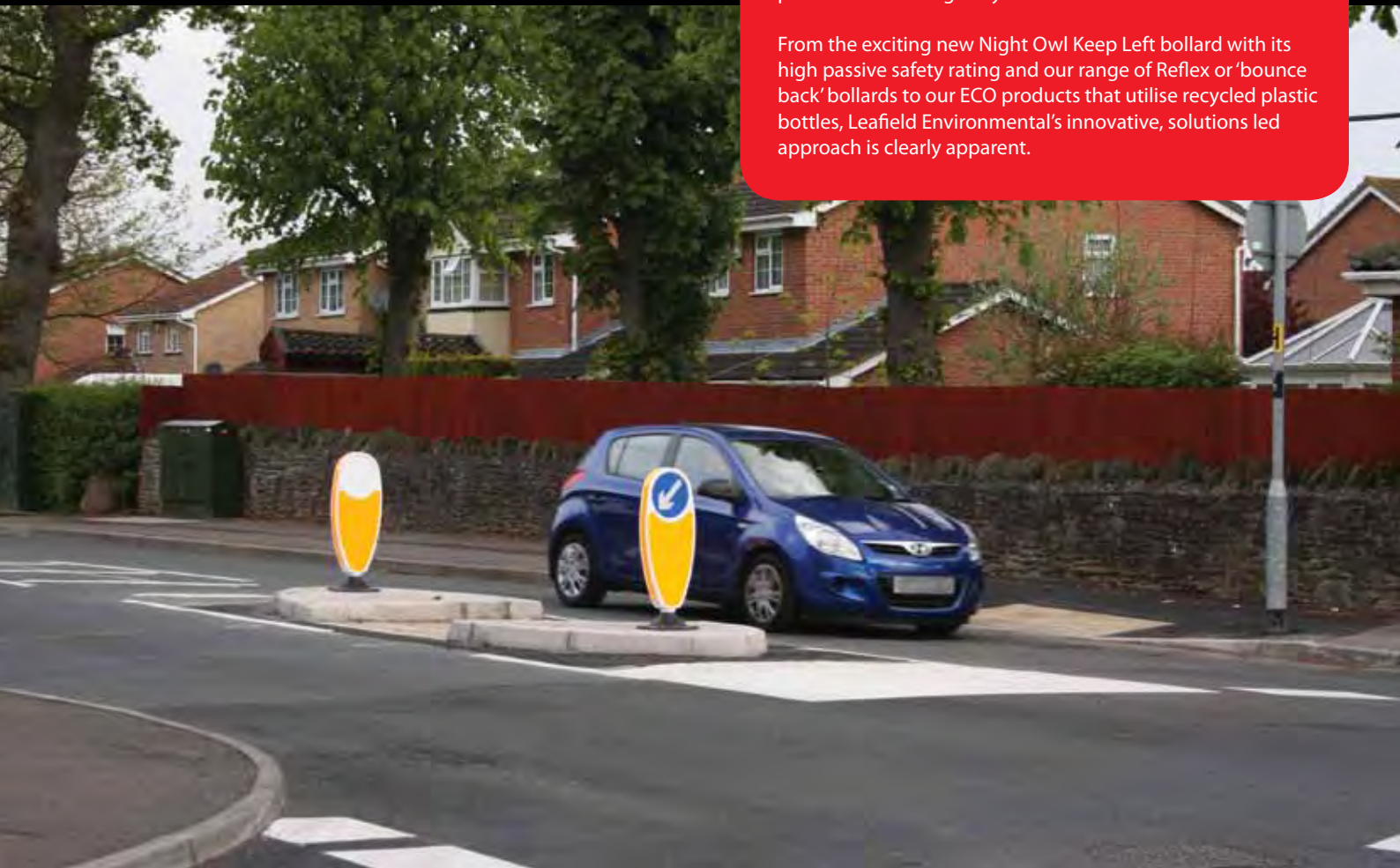

Tel: 01189 404717
Fax: 01189 403216
www.streetfurnishings.co.uk