

Servo-controlled solenoid valve NC, DN 25



A.u.K. Müller

Solenoid valves
Control valves
Special valves and systems

A.u.K. Müller GmbH & Co. KG
Dresdener Str. 162
D-40595 Düsseldorf/Germany

Tel.: +49 211 7391-0
Fax: +49 211 7391-281

e-mail: info@akmueller.de
Internet: www.akmueller.de

Series I4.025.126



Characteristics

- servo-controlled
- normally closed (NC)
- solenoid replaceable while medium circuit remains untouched, solenoid rotatable 4x90°
- lockable manual actuation
- flow limitation by adjustable stroke of membrane
- female metal thread
- similar hydraulic performance for AC or DC types
- optimized water hammer and noise emission according to EN 60730
- long term performance capability
- high operating safety by the use of high quality materials and 100% final testing of the products

Applications

- rain water utilisation
- air conditioning
- agricultural implements
- irrigation / gardening
- pollution equipment
- temperature equalisers
- water treatment
- swimming pool filling

Description

14.025.126 series water inlet valves are 2/2-way solenoid valves with an orifice size of 25 mm. They have been developed to control potable water and physically and chemically similar media. They are servo-controlled and normally closed (NC).

Valves of this design are single chamber straight through valves and can be manufactured with various connections equipped with metal female threads.

Coil systems for common voltage and frequency ranges are available.

Electrical operating safety is achieved by insulation class F and can be supported by an integrated protective circuit.

By using high quality insulation materials, continuous operation (duty cycle 100 %) is possible. Protection against corrosion of inner parts exposed to the medium is achieved by using stainless steel.

typical performance curve

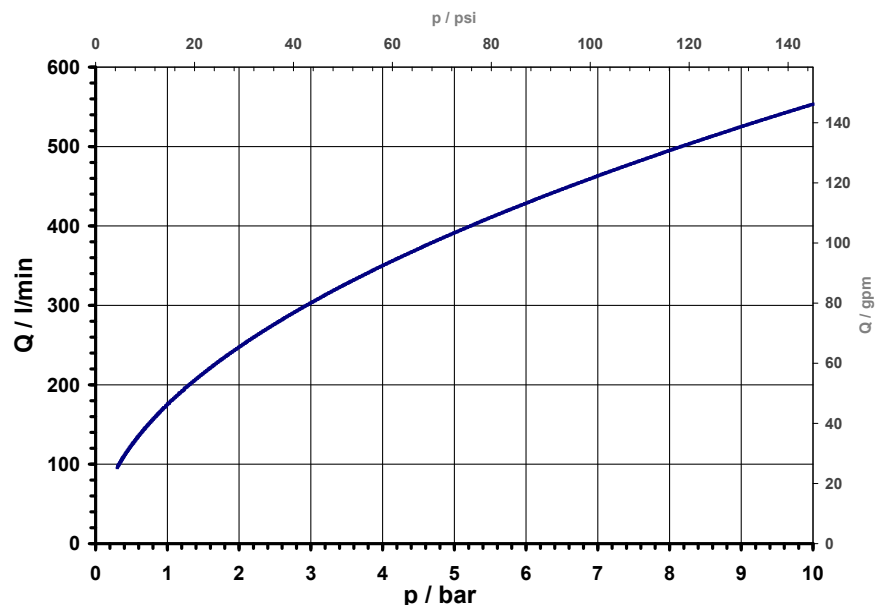



Series I4.025.I26

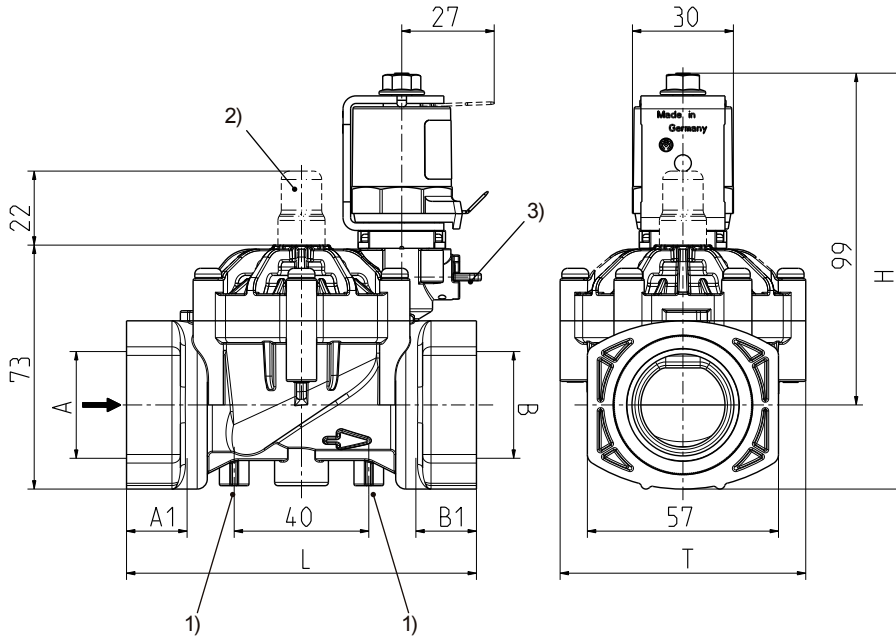

- 1) Fixing possibility for self tapping screw $\varnothing 4,2$
- 2) Flow limitation by adjustable stroke of membrane (option - available without flow adjustment)
- 3) Lockable manual actuation (shown in closed position)

Materials

Valve body	PA 6/6 glass fibre reinforced
Connection In- and outlet	brass CW614N stainless steel on request
Plunger guide	stainless steel
Plunger and spring	stainless steel
Membrane and sealings	EPDM NBR (on request) VMQ (on request)
Coil coating	PBT,PET or epoxy resin

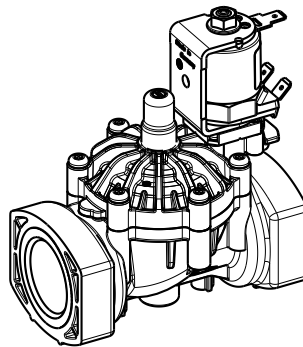

Technical Data

Type	solenoid valve	
Construction	2/2-way single chamber straight valve, servo-controlled	
Function	NC (normally closed)	
Fitting position	any, preferably with coil upwards	
Media	cold and heated potable water and physically and chemically similar media process water cooling water	
Viscosity	20	mm ² /s
T-Medium	4 - 30	°C (39.2 - 86.0 °F)
T-Ambient	60	°C (140 °F)
DN	25	mm (0.98 inch)
p-Operating	0,3 - 10,0	bar (4.4 - 145 psi)
Cv-value	175	l/min (46.2 gpm)
Flow regulator	adjustable stroke of membrane	
Pressure surge	according to EN 60730	
Coil type	MS.006, MS.024, MS.025	
Nominal voltages	220 - 240	V AC 50/60 Hz
	110	V AC 50/60 Hz
	24	V AC 50/60 Hz
	24	V DC
	12	V DC
	other voltages on request	
Voltage tolerance	+10% -15%	
Duty cycle	100%	
Nominal power	11 W	16 VA (AC only)
Protection Type	IP 00 up to IP 68	
Coil connections	flat tabs 6,3 x 0,8 mm plug socket according to EN 175301-803 (IP65), several cable connections (IP67, IP68)	
Insulation class	F	according to EN 60730
Protection class	I	according to EN 60730 (for incorporation in class I)

Options

Material	Inlet		Outlet		Length	Height	Depth	
	$\varnothing A$	A1	$\varnothing B$	B1				
PA 6/6	G 3/4 female	17 (0.67)	G 3/4 female	17 (0.67)	104 (4.09)	124 (4.88)	73 (2.87)	on request
PA 6/6	G 1 female	17 (0.67)	G 1 female	17 (0.67)	104 (4.09)	124 (4.88)	73 (2.87)	

dimension in mm (inch)



Series I4.025.I26

including flow rate limitation

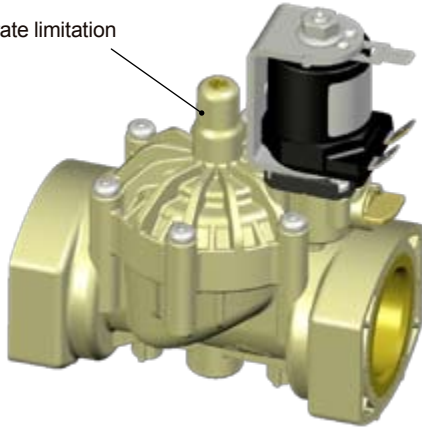

without flow rate limitation



The flow rate can be limited by turning the slotted screw in the valves cover cone.

- turning the screw clockwise lowers the flow rate
- + turning the screw anti-clockwise increases the flow rate

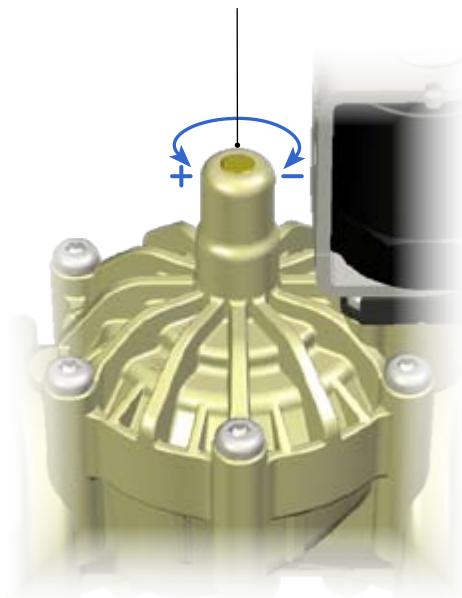

The adjusting screw can only be moved between predefined upper and lower positions and can not be removed. It should only be adjusted with care and without exerting any force at these upper and lower limits. It is not designed to be a manual shut-off for the valve.

Usually the adjusting screw has been set to the maximum flow rate by default.



Series I4.025.126

manual control position: closed



manual control position: open



manual control lever

Using the control lever the valve can be opened manually. This could be used if the equipment has to be filled before power-up or to continue flow in the event of a power failure.

- (A) The lever is usually set to the closed position by default.
- (B) Turning the lever clockwise to a vertical position opens the valve without powering the solenoid.
- (C) The valve is now open. Energising or de-energising the solenoid has no further effect. Turning the lever anti-clockwise back to position (A) will close the valve again.

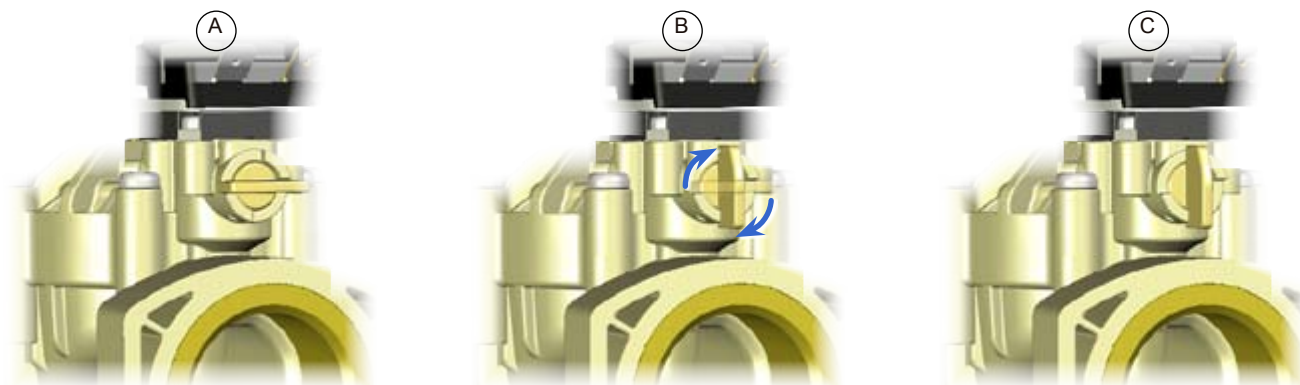

If the valve has been opened by energising the solenoid, any movement of the manual control lever will also have no effect. The lever should usually set back to position (A).