

Product Information

Flow meter turbine, with shut-off device



A.u.K. Müller

Solenoid valves
Control valves
Special valves and systems

A.u.K. Müller GmbH & Co. KG
Dresdener Str. 162
D-40595 Düsseldorf/Germany

Tel.: +49 211 7391-0
Fax: +49 211 7391-281

e-mail: info@akmueller.de
Internet: www.akmueller.de

Series 17.007

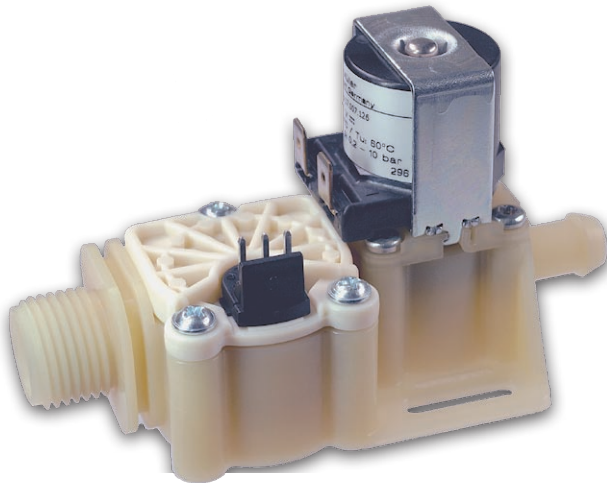

Characteristics

Flow meter turbine

- high degree of accuracy
- different measuring ranges configurable
- shut off via downstream solenoid valve

Valve

- servo controlled
- normally closed
- solenoid replaceable while medium circuit remains untouched, solenoid coil snaps into place
- minimized water hammer characteristic by low noise emission according to EN 60730

Applications

- liquid dosing
- volume recording
- laboratory equipment
- vending machines
- dispensing equipment
- washing machines

Description

The combination of a flow meter and a solenoid valve in one compact unit enables, with suitable electronics, the accurate metering of a liquid together with the ability to interrupt the flow.

A servo controlled valve avoids water hammer when connected to the mains supply.

This unit can be used for measuring, feedback control or dosing as it ensures accurate measurement of liquid volumes. The simple internal pulse transmitter offers a long life time without risk of failure.

To avoid air entry causing inaccurate measurements, the flow meter is sited upstream from the solenoid valve.

The flow meter's output are pulses, where the frequency or the number of pulses are equivalent to flow rate or volume.

Depending of the orifice used different measuring ranges can be achieved.

(for calculation see page 4)

typical performance curve
(orifice DN 5,0 on request)

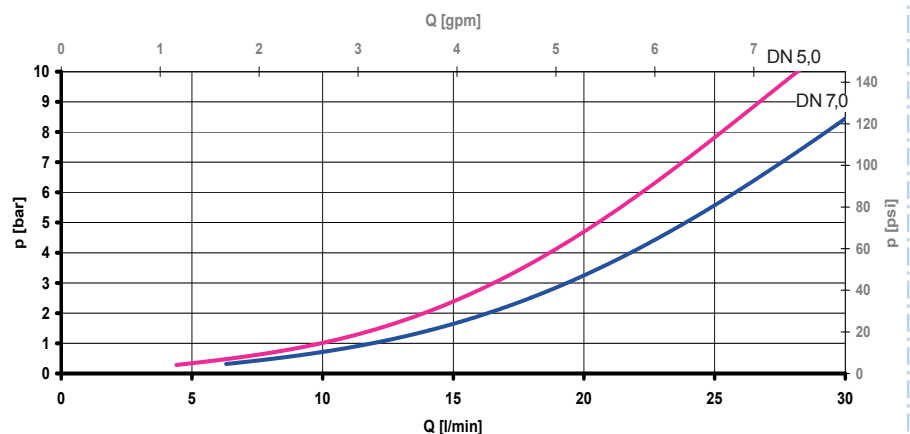

Product Information

Flow meter turbine, with shut-off device



A.u.K. Müller

Series I7.007

17.007.126

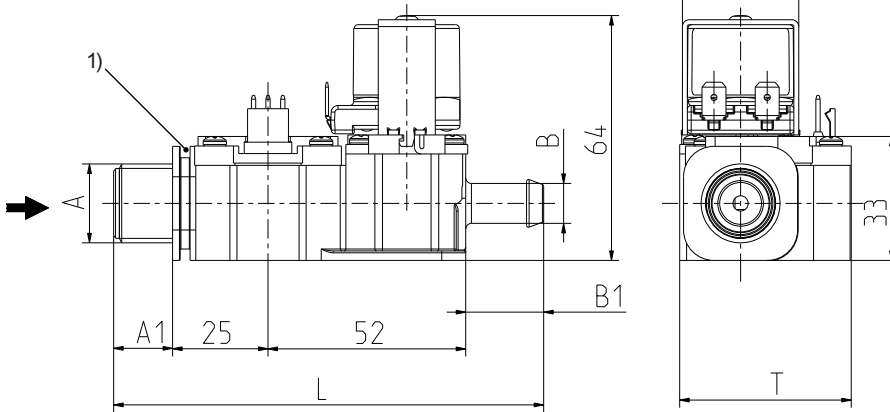

1) Fixing groove

Technical Data

Type	flow meter turbine with shut-off device	
Construction	flow meter, 2/2-way single chamber straight valve, servo-controlled optional: inlet ninety degree to outlet	
Function	volume/flow rate determination valve normally closed (NC)	
Fitting position	solenoid pointing upwards, for best results the flow meter should always be filled with liquid	
Media	cold and heated potable water and physically and chemically similar media	
T-Medium	60	°C max.
T-Ambient	60	°C max.
DN	7	mm
p-Operating	0,2 - 10	bar
Cv-value	12	l/min
Flow regulator	on request	
Pressure surge	according to EN 60730	

Materials

Valve body	PA 66 glass fibre reinforced PPE on request
Plunger guide	stainless steel
Plunger and spring	stainless steel
Membrane and sealings	EPDM NBR (on request) VMQ (on request)
Coil coating	PBT, PET or epoxy resin
Filter (inlet)	stainless steel
Flow meter cover	PBT
Slide bearing pin	1.4305 (18/8) 1.4571 on request
O-ring	EPDM MVQ on request FPM on request
Turbine	PVDF
Magnet	SrFeO

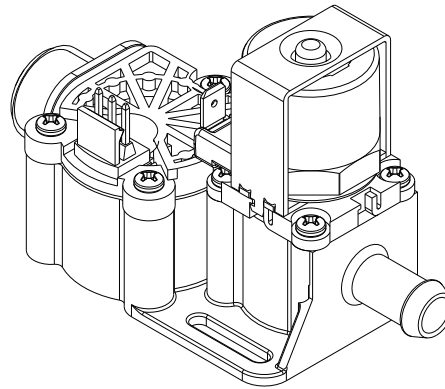

Options

Material	Inlet	A1	Outlet	B1	Length	Height	Depth	
	Ø A		Ø B		L	H	T	
PA 66	G 3/4	20,5	G 3/4	15,5	113	64	46	*)
PA 66	G 1/2	15,5	10,5 nozzle	15,5	108	64	46	
PA 66	G 1/2	15,5	G 1/2	15,5	108	64	46	
PA 66	12 John Guest	18,0	8 John Guest	15,5	111	64	46	*)
PA 66	G 3/8	15,5	G 3/8	15,5	108	64	46	*)

*) on request



Series 17.007

17.007.115

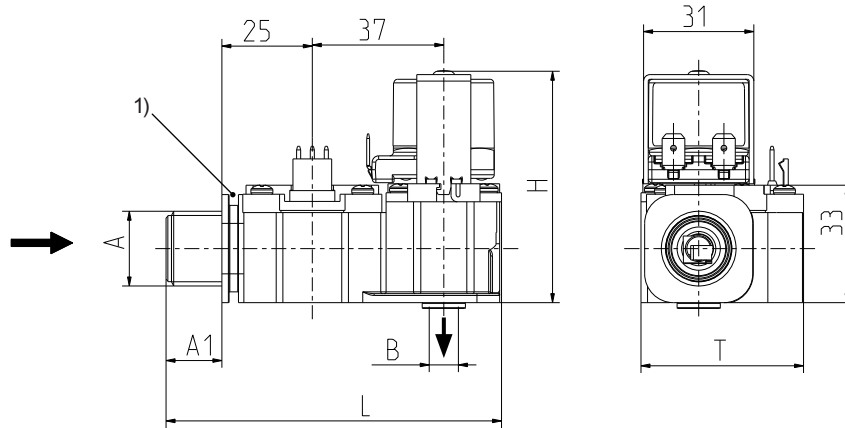

1) Fixing groove

Options

Material	Inlet		Outlet	Length	Height	Depth	
	Ø A	A1	Ø B	L	H	T	
PA 66	G 1/2	15,5	8 John Guest	96	64	46	*)
PA 66	G 1/2	15,5	6 John Guest	96	64	46	
PA 66	G 1/2	15,5	5 John Guest	96	64	46	*)
PA 66	12 John Guest	18,0	8 John Guest	99	64	46	*)
PA 66	12 John Guest	18,0	6 John Guest	99	64	46	*)
PA 66	12 John Guest	18,0	5 John Guest	99	64	46	*)

*) on request

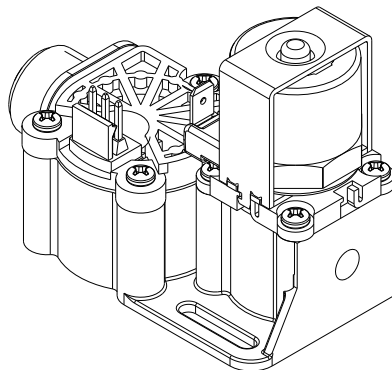



Series I7.007

Technical Data

Valve	
Coil type	MS.026
Nominal voltages	220 - 240 V AC 50-60 Hz
	110 V AC 50 Hz
	110 - 127 V AC 60 Hz
	24 V AC 50/60 Hz
	12 V AC 50/60 Hz
	24 V DC
	12 V DC
	other voltages on request
Voltage tolerance	+10% -15%
Duty cycle	100%
Nominal power	6,5 W 7,5 VA (AC only)
Protection Type	IP 00
Coil connections	flat tabs 6,3 x 0,8 mm
Insulation class	F according to EN 60730
Protection class	I according to EN 60730 (for incorporation in class I)

Flow meter turbine	
Flow rate	30,0 l/min max.
Nominal voltages	4,5 - 24 V DC
Current consumption	5 - 13 mA
Signal connection	open collector NPN
Signal voltage	0 V GND
Signal	square-wave output
Duty factor of pulse	50% +/- 5%
Signal load	20 mA max.
Leakage current	10 µA max.
Connections	PANCON MAS-CON 156 MLSS (3 x AMP 2,8 x 0,8 mm)

Please note the following advice for optimum results of the flow meter:

- avoid rapid pulsating delivery of the medium
- avoid pressure surges
- avoid air trapped in flow meter or pipes
- take fitting position of the flow meter into account
- min/max flow rate should be within the linear measuring range for each selected orifice
- regular cleaning at reasonable intervals

	orifices Ø mm	constant pulses / l *)	metering accuracy	Q min l/min	Q max l/min	p-Operating bar
	7,0	94	± 3,0%	6,3	30,0	0,2 - 10
on request	5,0	262		4,4	28,0	

The constant (pulses/litre) are approximated values and may differ depending on installation and medium. It is recommended to evaluate the pulses/l within the actual installation more accurately.

Orifice sizes could be customized on request.

*) With ... constant [Pulse / Litre]
...you determine volume or flow rate.

- Volume determination via count of pulses

$$\text{volume [Litre]} = \frac{\text{number of pulse}}{\text{constant}}$$

- Flow rate determination via measurement of pulse frequency

$$\text{flow rate [Litre/Second]} = \frac{\text{frequency [Hz]}}{\text{constant}}$$



Series 17.007

Connecting options

PANCON MAS-CON 156 MLSS

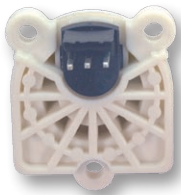

3 x AMP 2,8 x 0,8 mm

Display



Please note the following advice for optimum results of the flow meter:

- avoid peaks of current
- incorrect polarity of voltage supply (+), signal and ground may destroy the flow meter
- don't apply mechanical load on electrical terminals
- avoid humidity on electrical terminals
- avoid inductive interferences via cable (cable should not run parallel to power supply cables of appliances with high power consumption)

Connecting examples

