

Pinch valve, 2/2-way, NO



A.u.K. Müller

Solenoid valves
Control valves
Special valves and systems

A.u.K. Müller GmbH & Co. KG
Dresdener Str. 162
D-40595 Düsseldorf/Germany

Tel.: +49 211 7391-0
Fax: +49 211 7391-281

e-mail: info@akmueller.de
Internet: www.akmueller.de

Series 16.003.225



Characteristics

- medium completely separated from valve parts
- chemical resistance depends on the material of the tube selected
- tube can easily be changed
- no dead areas as in usual valve body
- flow in either direction
- coil can be fixed in any position through 360°
- minimum 1 million cycles (dry, without medium)

Applications

- dosage systems
- laboratory analysis
- medical equipment
- vending machines

Description

The 16.003.225 pinch valve series is normally open in operation and is designed for flexible tubes up to an outer diameter of 5,2 mm and a shore hardness of 50 - 60.

The flow of the medium is controlled by pinching the inserted tube. This design avoids using the traditional valve seat and membrane which can cause turbulence in the fluid flow and create dead areas in the valve housing where medium or dirt can collect. The valve is particularly suitable for applications where a high level of hygiene is required.

The resistance against chemicals depends on the selected material of the tube.

Typical performance curve
Silicone tube 2,85x1,1; 60°Sh; length 30cm
Medium: Water at 25°C; Free Outlet

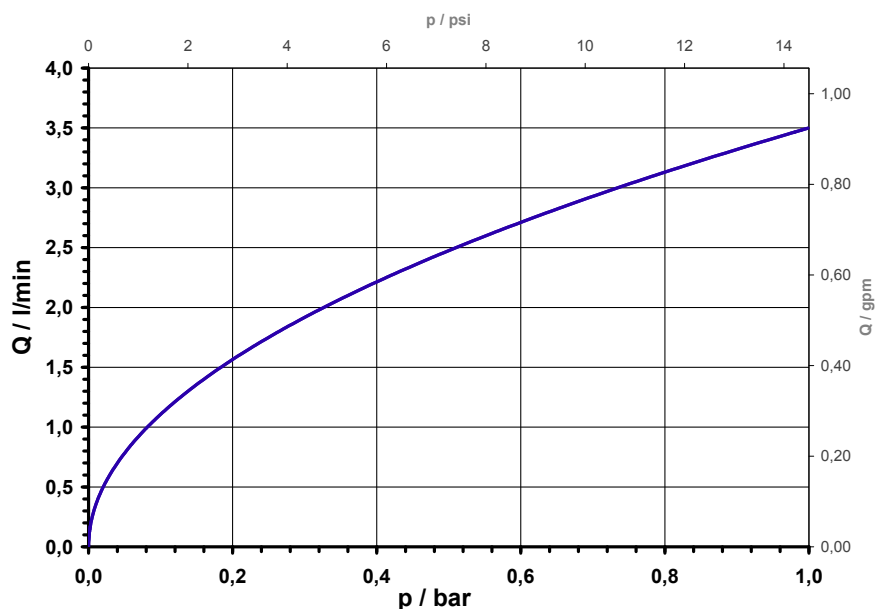



Series I6.003.225

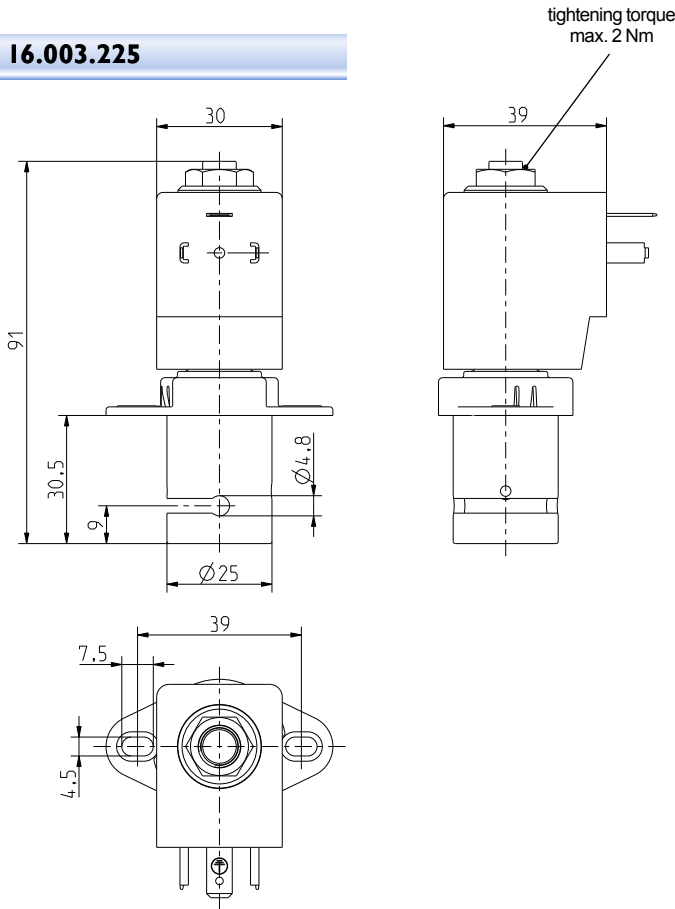

Technical Data

Type	pinch valve	
Construction	2/2-way solenoid valve, direct acting	
Function	NO (normally open)	
Fitting position	any	
Media	depends on tube	
T-Medium	90 (194)	°C max. °F max.)
T-Ambient	-10 – +50 (14 – 122)	°C °F)
p-Operating	0 - 1 bar (0 - 14,5 psi) (depending on tube)	
Coil type	MS.037-30	
Nominal voltages	24	V DC
	other voltages on request	
Voltage tolerance	±10%	
Duty cycle	100%	
Protection Type	IP 65	
Coil connections	plug socket according to EN 175301-803 (IP65)	
Insulation class	F	according to EN 60730

Materials

Valve body	aluminium (surface refined)
Fixing flange	PA 66, glass fibre reinforced
Plunger guide	aluminium, PTFE
Plunger and spring	stainless steel
Coil coating	PA 6, glass fibre reinforced

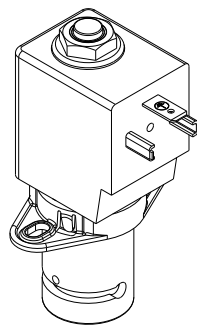

Options

I.D. Ø	O.D. Ø	Wall Thickness	Shore-Hardness	Clamping-Force / N	Nominal power consumption / W
3,0	5,0	1,0	60°±5°	4,5	11,0

Range of possible outer diameter (O.D.Ø) of tube: 4,0 - 5,2 mm.
 The wall thickness should not deviate from the ones derived in the upper table.
 The valve may only be operated with inserted tube.

