

V-Track™ Automatic Long Range Vehicle ID System

Installation Guide

1.0 System Overview

The Keri V-Track™ System¹ is similar to the highway toll type systems such as *E-ZPass*®² or *FasTrak*®² in that they both operate in the 900 MHz band. However, V-Track™ is much easier to install and far more tolerant of different vehicle types and metal surroundings than the toll-authority type transponder. It is also far less expensive.

The V-Track™ Vehicle Identification System consists of a directional Exciter (EX-10 - consisting of an integrated transmitter and antenna), which sends out a uniquely coded RF signal towards the vehicle. The Transponder (LRT-10) is mounted on the vehicle's windshield. Once the Transponder enters the field and recognizes the coded signal, it "wakes up" and transmits its ID number via a secure RF signal to a Receiver decoder (RXR-10). The Receiver can be located up to 100 feet (30M) away from the vehicle. The Receiver is supplied in a weatherproof enclosure for direct outdoor installation or can be placed indoors, such as in a guardhouse, close to other electronic equipment. The Receiver outputs the decoded data to an access control unit via standard data cabling. Systems are available that output data in either the standard Keri MS format or in 26-bit Wiegand format. A second or exit lane can be added to the system by installing a second Exciter. This Exciter is aimed down the exit lane in the same manner as the entrance lane's Exciter.

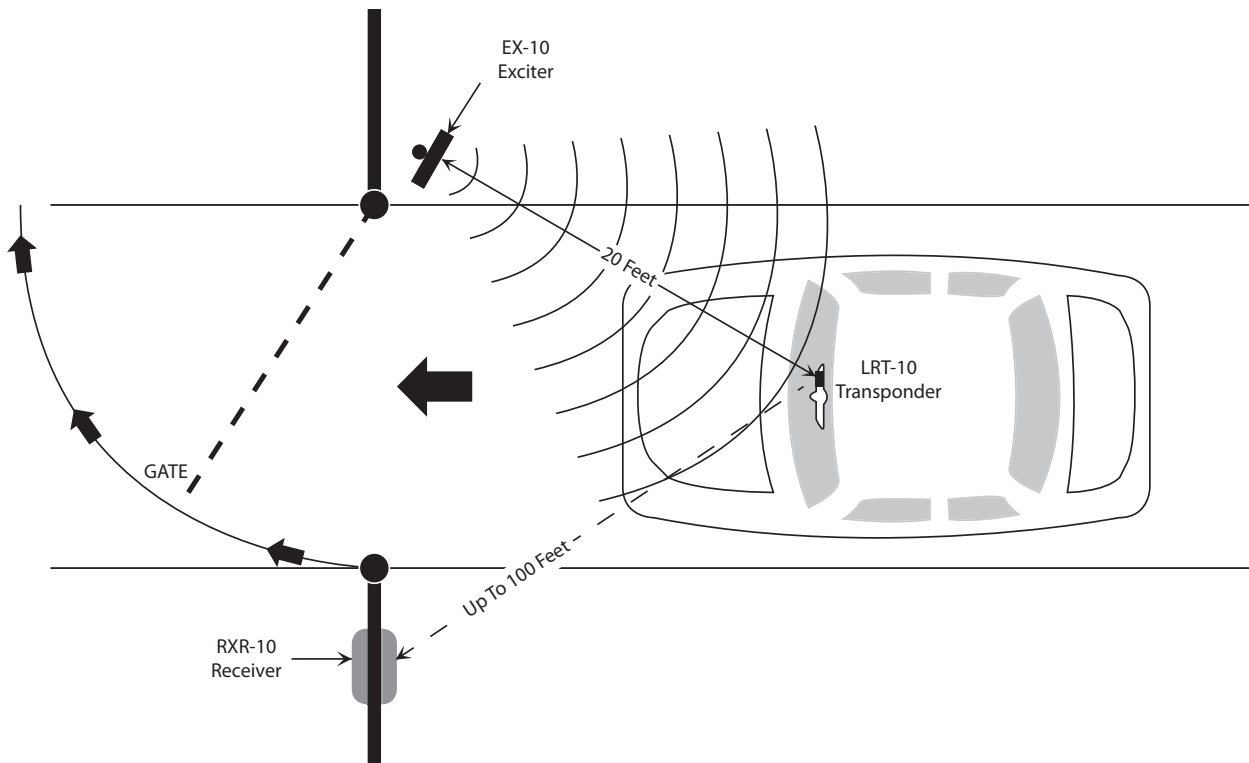

Figure 1: Basic, Single-Lane Gate Controller

1. This device complies with part 15 of the FCC Rules. Operation is subject to the following two conditions: (1) This device may not cause harmful interference, and (2) this device must accept any interference received, including interference that may cause undesired operation.
2. *E-ZPass*® and *FasTrak*® are registered trademarks of *E-ZPass*® New York and the Bay Area Toll Authority, respectively.

V-Track™ Automatic Long Range Vehicle ID System

Installation Guide

Installation and setup is made simple and easy through the use of a Test Transponder (TT-1) which displays a blinking LED when it is excited by the EX-10 and when it transmits its ID code. This allows for a quick range check and adjustment of the Transmitter's antenna height and angle. It can be used to simulate a vehicle or actually placed in a vehicle to test for proper operation which will quickly show where the Transponder will turn on for any particular vehicle. Keep in mind, the read range in a small convertible will be different than that of a large pickup or SUV, but is usually in the 15' - 25' (5-7 M) range.

2.0 EX-10 Exciter Installation

The EX-10 Exciter should be installed two to four feet (70 to 130 cm) from the edge of the entry lane. A gimbal mount is provided allowing for flexible horizontal and vertical orientation of the Exciter. Antenna horizontal and vertical radiation patterns are shown below. An Exciter height of five to nine feet above the ground is recommended, with six to seven feet (180 to 210 cm) being a typical height. The area between the antenna and the vehicle lane must be clear of shrubbery higher than 3 feet (90 cm). Low growing shrubs are acceptable. Taller plants immediately around the Exciter mounting pole (to hide the pole) are acceptable as long as they are two to three feet below the aimed antenna within the Exciter unit. The antenna housing may also be painted to blend in with its surroundings so long as a NON-metallic paint is used.

The Exciter's response-to-vehicle transponder time is set for typical gate operation use. Contact the factory for high-speed operations.

NOTE: A Yagi antenna may also be used instead of the standard, integrated antenna, if the installation application so dictates. Please contact Keri Systems for additional information and ordering of the Yagi antenna.

2.1 Exciter Orientation

2.1.1 Horizontal Plane

The horizontal orientation of the Exciter is set so that the center of the pattern is directed at the right edge of the road, which permits the left half of the detection pattern to cover most of the entry lane. Refer to Figure 2.

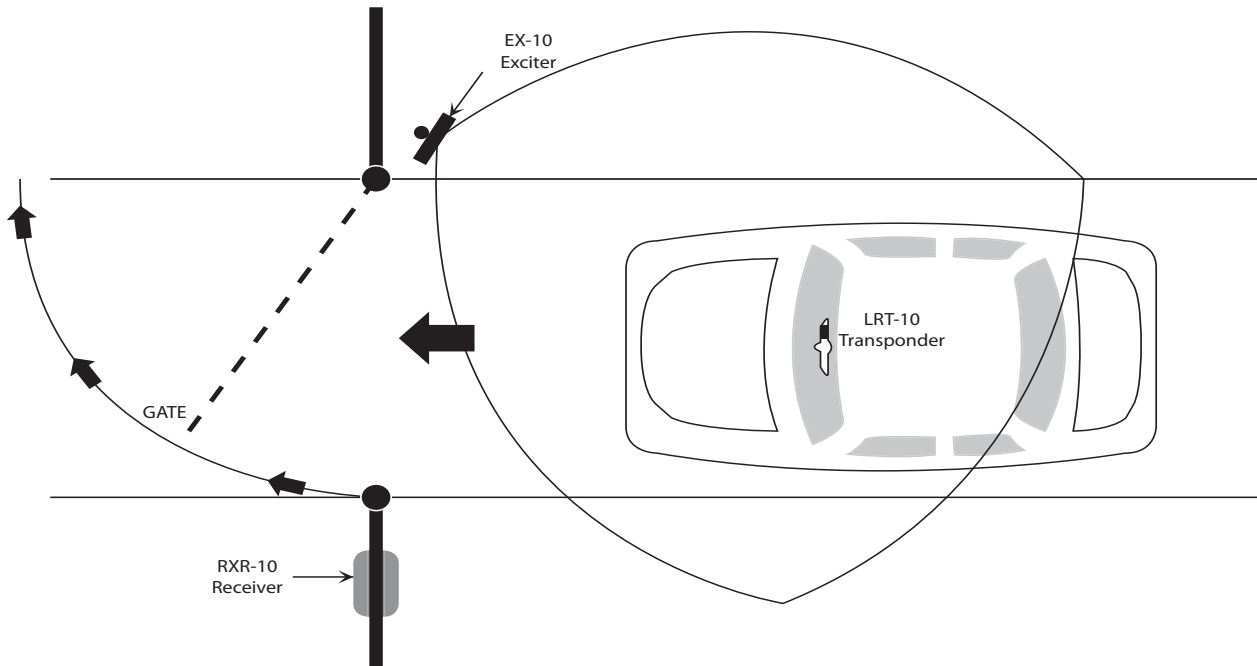

Figure 2: The Horizontal Antenna Coverage Pattern

V-Track™ Automatic Long Range Vehicle ID System

Installation Guide

2.1.2 Vertical Plane

Vertical orientation is adjusted so as to aim the antenna at a spot about twenty feet (6.5 M) on the road from the Exciter. From this spot forward, the detection area will increase as you get closer to the gate. This is shown in Figure 3.

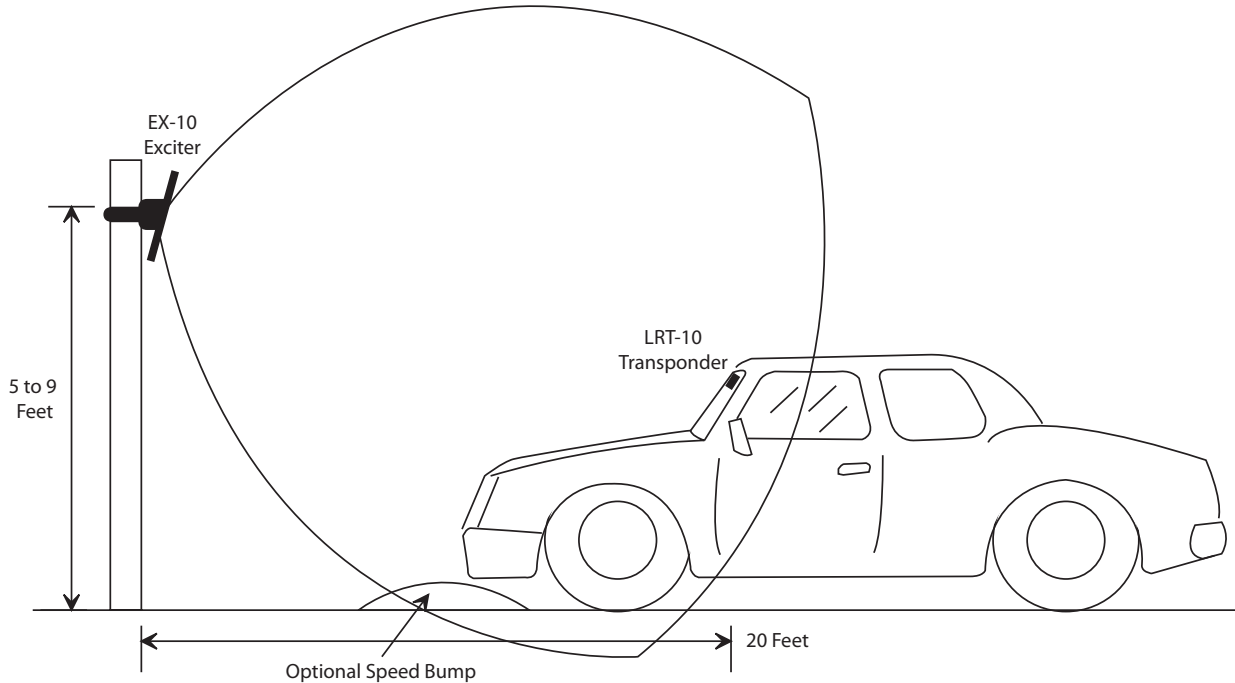

Figure 3: The Vertical Antenna Coverage Pattern

2.1.3 External Arming Input

Some installations prefer that the V-Track not be active until a vehicle approaches. The V-Track system is built with an input for external arming. This allows the use of road loops, IR detectors, pressure sensors, etc. to activate the V-Track system Antenna/Exciter. This system is not active until the loop input wires (brown and blue on the Exciter) are shorted together. This can be accomplished by using the arming devices output; either an open collector or the dry contacts of a relay.

The blue wire is the high input and the brown wire is the low (ground). If there is no external arming device used, these two wires must be connected together and this will turn the Antenna/Exciter on and allow it to function any time a transponder is in range.

V-Track™ Automatic Long Range Vehicle ID System

Installation Guide

2.2 Exciter Electrical Installation

The Exciter comes configured from the factory for single-lane or for dual-lane entrance/dual-lane exit applications. Make wiring connections as follows:

- In single-lane applications only the Power (red) and Ground/Shield (black/silver) connections are made. Clip off the unneeded Green and White wires.
- In dual-lane applications, connect the A-wire (white) to the LRT Receiver at J3) and connect the B-wire (green) to the LRT Receiver at J3. Then connect the Power (red) and Ground/Shield (black/silver) wires.
- If the Arming Input is not being used, the Arming Input High (blue) and Arming Input Low (brown) wires **MUST** be shorted.

Please refer to Section 6.0 in this Installation Guide for more information on Enter/Exit (two-lane) applications.

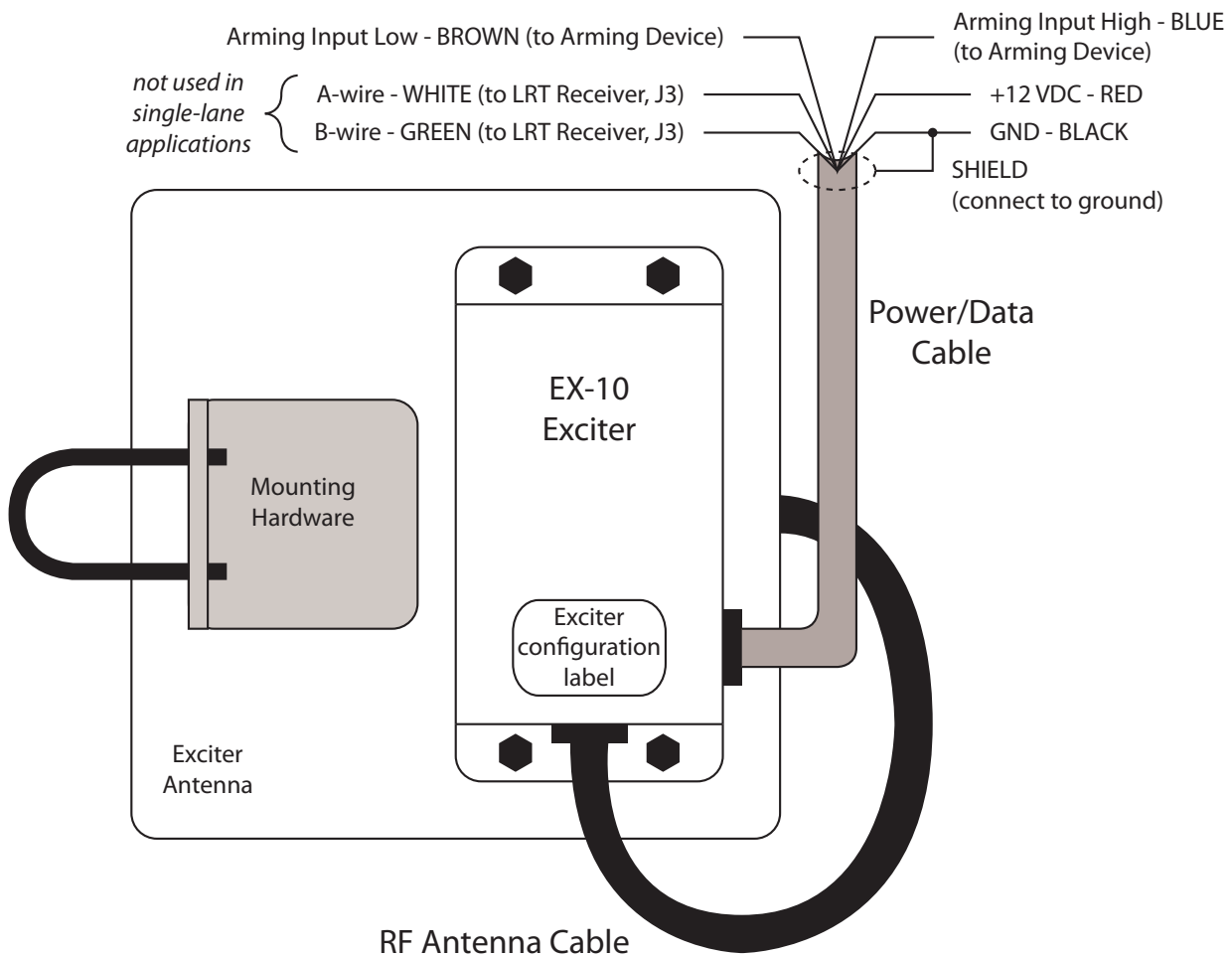

Figure 4: Exciter PCB

V-Track™ Automatic Long Range Vehicle ID System Installation Guide

Table 1: EX-10 Exciter Electrical Requirements

Parameter	Requirement
Power Supply Nominal DC Voltage	12.0 VDC
Voltage Range	11.0 VDC to 15.0 VDC
Nominal Current	500 mA
Recommended Power Supply	12 VDC @ 1 A or greater fully regulated
RF Connector Type	RPSMA

Keri recommends the following cable gauges:

- AWG 18 allows up to 500 feet
- AWG 22 allows up to 200 feet
- AWG 24 allows up to 100 feet

2.3 The Exciter's Antenna

The EX-10 Exciter's antenna can have a gain of no more than 8.1 db, per FCC regulations. For best operation the coaxial cable between the antenna and transmitter should be kept as short as practical. We recommend no more than 10 feet. Longer coax lengths than this will reduce the operating range of the system.

NOTE: The cable seals in the body of the Exciter enclosure are designed to accommodate one cable. Forcing more than one cable through these seals compromises the weather-tight seal, allowing water to enter the body of the enclosure.

V-Track™ Automatic Long Range Vehicle ID System

Installation Guide

3.0 RXR-10 Receiver Installation

The Receiver range pattern is omnidirectional, a large, circular shape with a radius of up to 100 feet (30M). A typical mounting location is in a gatehouse for gated communities, or other enclosure, which makes it convenient to provide a data cable from the Receiver to the control unit. An external antenna can be installed if the Receiver is mounted in a difficult RF signal area. The LRT-10 Transponder sends its signal to the Receiver at 433 MHz so the detection pattern is very similar to that of a garage door opener or the remote unlock on your automobile. Cable type and run length are like any proximity reader and are specified below. The Receiver antenna detection pattern is shown in Figure 5.

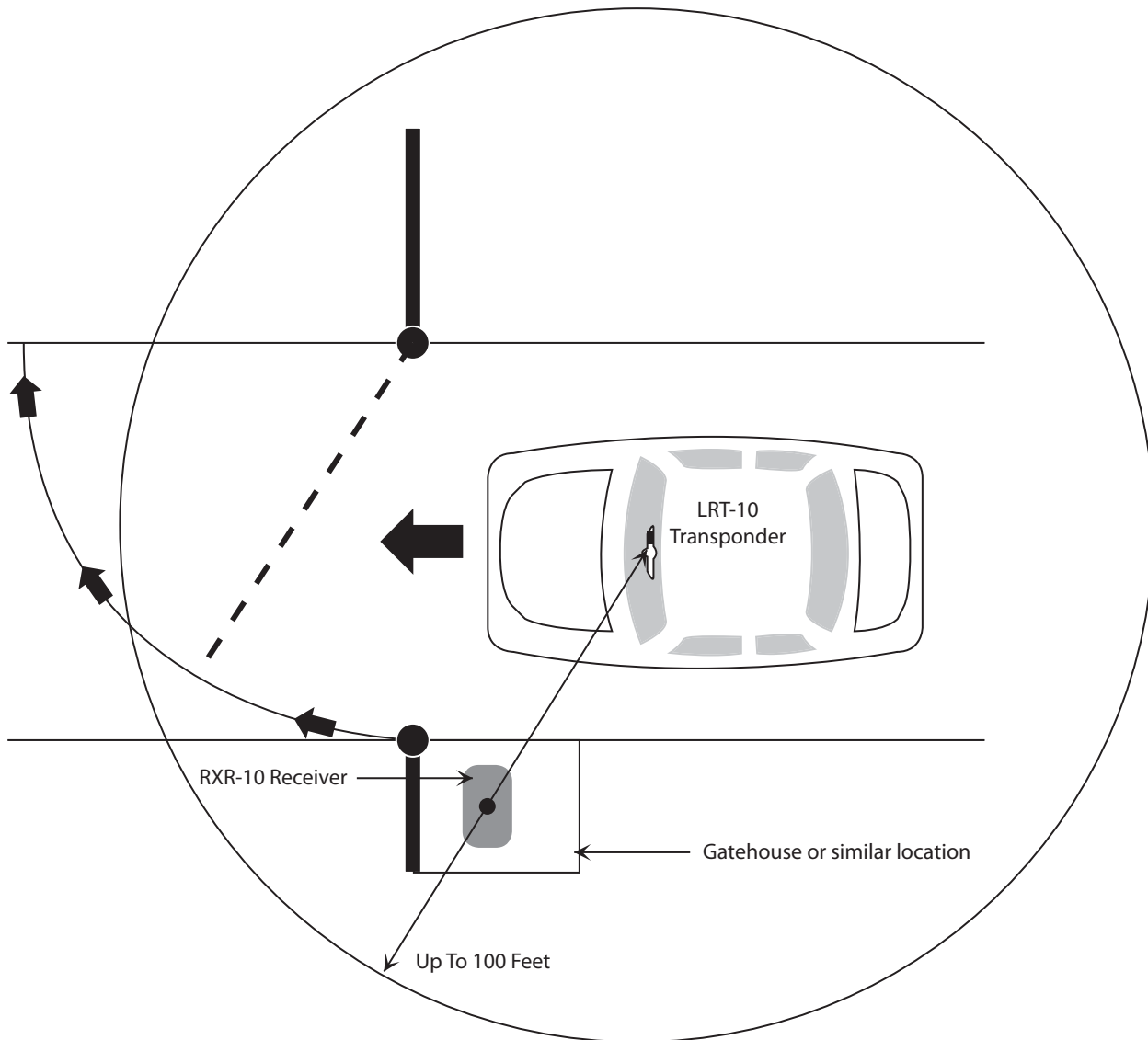

Figure 5: RXR-10 Receiver Detection Pattern – 100 Foot Radius Circle

The PC Board outline for the RXR-10 Receiver is shown in Figure 6 on page 7. The Receiver is equipped with a Range adjustment potentiometer (RV1). For single lane applications the system installer only needs to supply DC power to the Receiver and Exciter. For information on Enter/Exit applications, please refer to Section 6.0 in this Installation Guide.

V-Track™ Automatic Long Range Vehicle ID System

Installation Guide

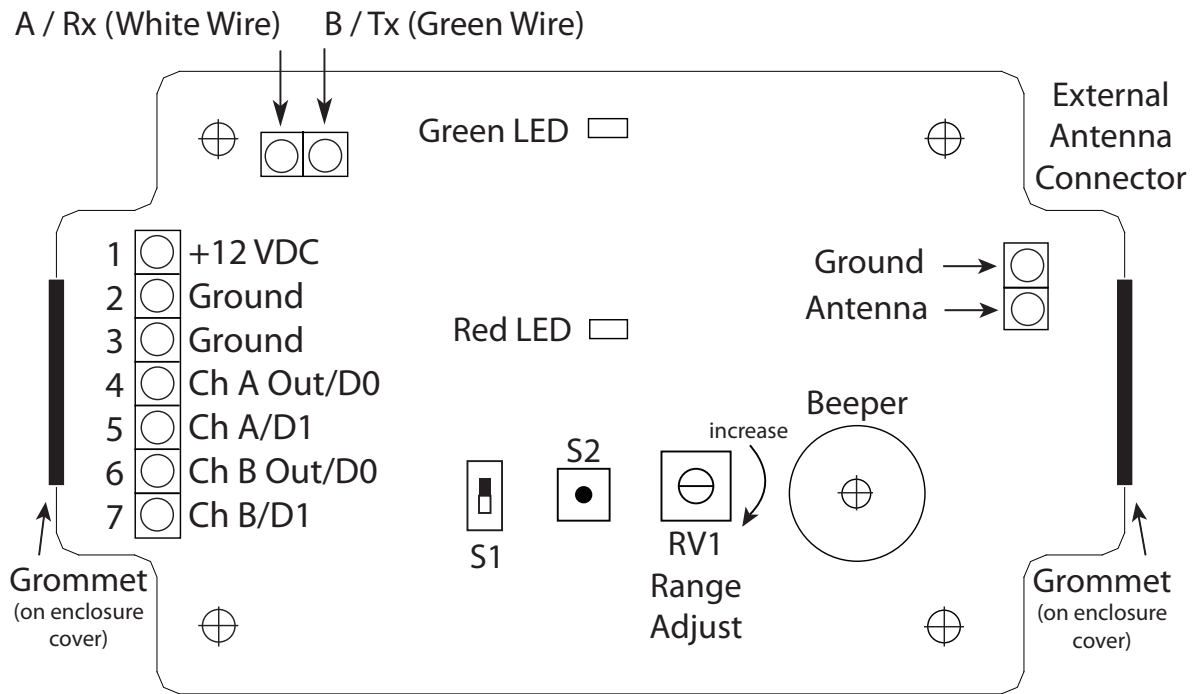

Figure 6: Receiver PCB

Table 2: RXR-10 Receiver Electrical Requirements

Parameter	Requirement
Power Supply Nominal DC Voltage	12.0 VDC
Voltage Range	11.0 VDC to 15.0 VDC
Nominal Current	100 mA
Recommended Power Supply	12 VDC @ 250 mA or greater, fully regulated, - Receiver can be powered by the host controller's 12 VDC supply

Keri recommends the following cable gauges:

- AWG 22 allows up to 500 feet
- AWG 24 allows up to 200 feet

Wire the Receiver to the access panel per the appropriate diagram in Section 7.3.

NOTE: The cable seals in the body of the Receiver enclosure are designed to accommodate one cable. Forcing more than one cable through these seals compromises the weather-tight seal, allowing water to enter the body of the enclosure.

V-Track™ Automatic Long Range Vehicle ID System

Installation Guide

4.0 V-Track System Setup and Checkout

The Setup and Checkout process requires the use of a TT-1 Test Transponder. The TT-1 is equipped with an LED that flashes Green when the Transponder recognizes a signal from the Exciter and flashes Red every time the Transponder transmits its ID code to the Receiver.

Perform the following steps after you have installed and wired the V-Track system equipment:

1. Short together the Arming Input Low and High lines (the Brown and Blue wires) on the EX-10 Exciter.
2. Remove the cover from the RXR-10 Receiver and maximize Receiver sensitivity by rotating the range potentiometer (RV1) fully clockwise (see Figure 6).
3. Power up the Receiver and the EX-10 Exciter.
4. Place the Test Transponder into the vehicle travel lane within the Exciter's signal field and the Receiver's detection field. The Transponder's LED will blink green while within the Exciter's signal field and will blink red when it transmits an ID code to the Receiver (see Figure 7).
5. Correspondingly, while the Transponder is in the vehicle travel lane, the Receiver's green LED will blink off/on to indicate the Receiver recognizes the Transponder is within range and the Receiver's red LED will flash off every 20 seconds to indicate the Transponder's ID code was transmitted by the Receiver to the access control panel.

NOTE: In standard operation the Receiver sends Transponder ID data to the access control system every 20 seconds for as long as a Transponder remains in the Exciter's field. This feature, called Last Card Lock Out (LCLO), prevents the Receiver from overwhelming an access control system with repeated submissions of the same Transponder ID. In standard operation, when a new ID is received (when a new Transponder enters the vehicle travel lane), the Receiver will send the new ID immediately and apply LCLO to the new ID.

6. If the LED functions between Transponder and Receiver are not consistent, there is a problem with signal coverage in the vehicle travel lane. Verify the Receiver is within 100 feet of the desired coverage area (see Figure 5) and the Exciter is properly oriented (see Figure 2 and Figure 3) to cover the vehicle travel lane.
7. If the LED functions between Transponder and Receiver are consistent, you can further verify proper operation by presenting an LRT-10 Transponder into the vehicle travel lane and verifying the ID code being sent by the Receiver to the access control system is correct by comparing the ID code on the Transponder to the ID code displayed by the access control system software.
8. Remove the short between the Arming Input Low and High lines (the Brown and Blue wires) on the EX-10 Exciter.

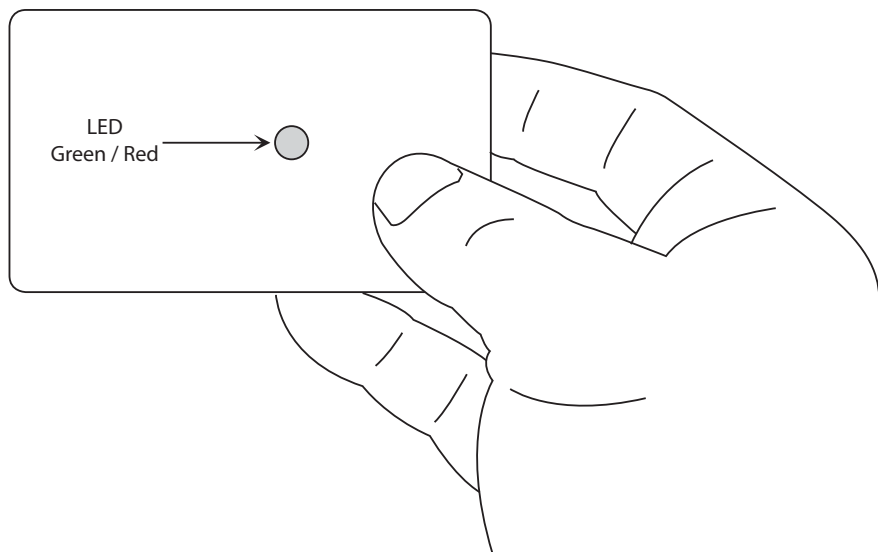

Figure 7: TT-1 Presentation Orientation for Field Test

V-Track™ Automatic Long Range Vehicle ID System

Installation Guide

4.1 Receiver Sensitivity Adjustment

For installations of a single Receiver, it is typically fine to leave the sensitivity control at maximum (the factory default setting).

Installations that have access points 500 feet or less apart require Receiver sensitivity adjustment. Receivers are designed to be sensitive, long range devices to offer the best possible operation. As a result, if you have access points in reasonably close proximity the Transponder signal may be received by more than one Receiver. This results in incorrect system operation and must not be allowed to happen.

If your site has access points in close proximity, following the System Setup and Checkout procedure Keri recommends the following:

1. Remove the Receiver cover. There two LEDs, one Red and one Green (see Figure 6 on page 7). The Green LED blinks off when a Transponder is in range and the Red LED blinks off when a proper code is detected and data is shipped to the host controller.
2. Place your Test Transponder in the field of Access Point A. Make certain that the LED on the Test Transponder is blinking indicating proper operation. Now, look at any nearby Receiver other than that of Access Point A. If its Green LED is blinking, the sensitivity of that Receiver must be reduced by turning the control in a counter clockwise direction. Reduce this setting until the Green LED no longer blinks, then turn an additional 1-2 degrees for a safety margin.
3. This procedure needs to be repeated at all Receivers, until all Access Points have been tested. Of course this means that the Test Transponder will need to be placed at the antenna of each gate and all nearby Receivers checked for proper sensitivity settings.
4. When this is completed, test to make sure the Transponder is still seen on the desired Receiver. If it is not possible to reduce unwanted Transponder reads without degrading the desired signals, then the Receivers will need to be placed further apart.

With multiple gates, this task will take a few minutes per Access Point, but is well worth the time spent as it eliminates the possibility of a vehicle opening an Access Point other than the one it is entering.

4.2 Transponder Enrolling

The V-Track Transponders you receive should be in consecutive ID numbers with no breaks or missing numbers. Keri recommends enrolling these Transponders using the block enrollment feature provided by the Keri software (enrolling all consecutively numbered Transponders into the cardholder database at one time by number range). If you are intending to use learn enrollment (presenting Transponders to a reader one-at-a-time) please contact Keri Technical Support for information.

V-Track™ Automatic Long Range Vehicle ID System Installation Guide

5.0 LRT Vehicle Installation

Figure 8 shows the optimal placement of the Transponder in order of signal response performance. Install the Transponder using the provided double-sided tape or Velcro™ (see Figure 9 on page 10). Ensure the label-end of the Transponder is mounted away from the rear-view mirror's mounting post. Prior to installation, make certain the desired location complies with all state and local vehicle code laws. Optimal placement of the Transponder is behind the rear-view mirror, out of the driver's vision (Location 1, below).

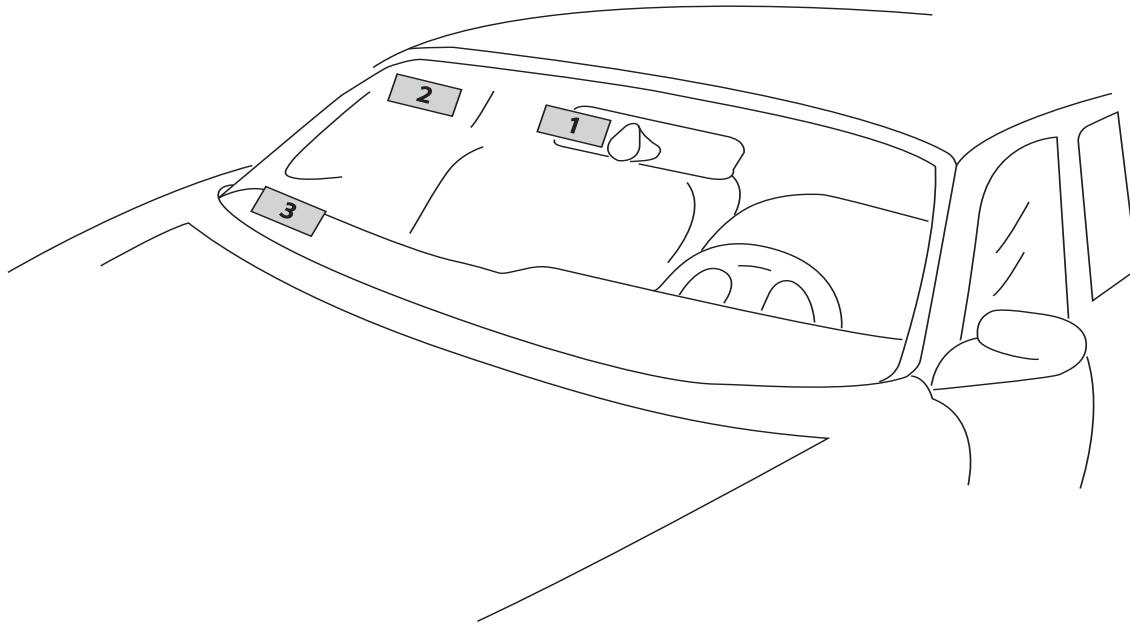

Figure 8: Optimal Transponder Installation Locations

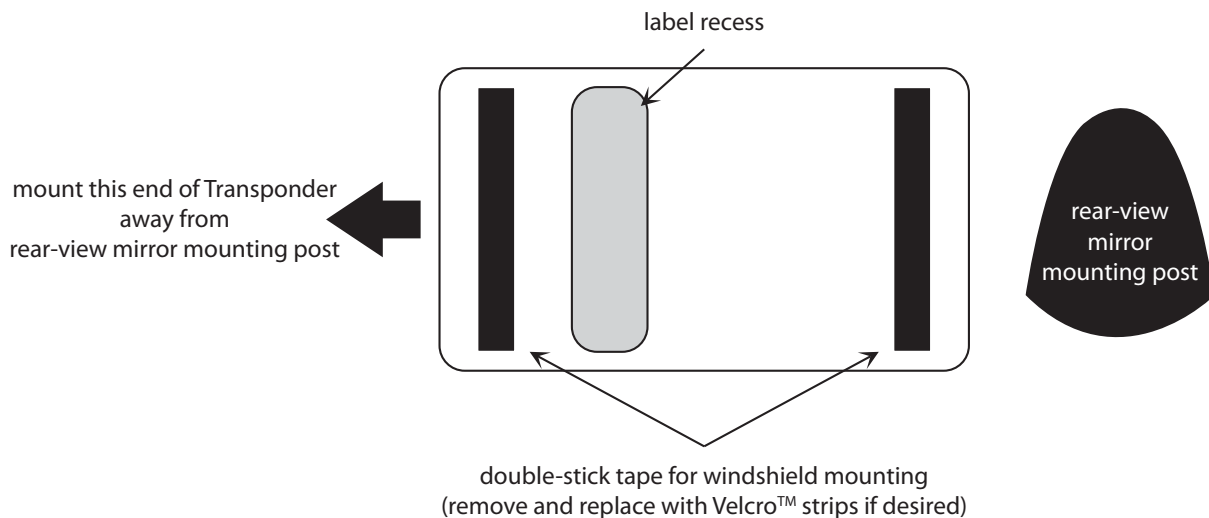

Figure 9: Transponder Mounting Tape

V-Track™ Automatic Long Range Vehicle ID System Installation Guide

6.0 Enter-Exit Lane Installation

The Keri RXR-10 receiver has the capability of controlling two EX-10 Exciters for Enter/Exit applications (see Figure 10). The EX-10 Exciter should arrive configured for your application from the factor. Labels on the Exciter cover identify individual units as either Single-Lane, Dual-Lane IN, or Dual-Lane OUT. Refer to Section 8.0 on page 18 should you need to reconfigure an Exciter for a new purpose.

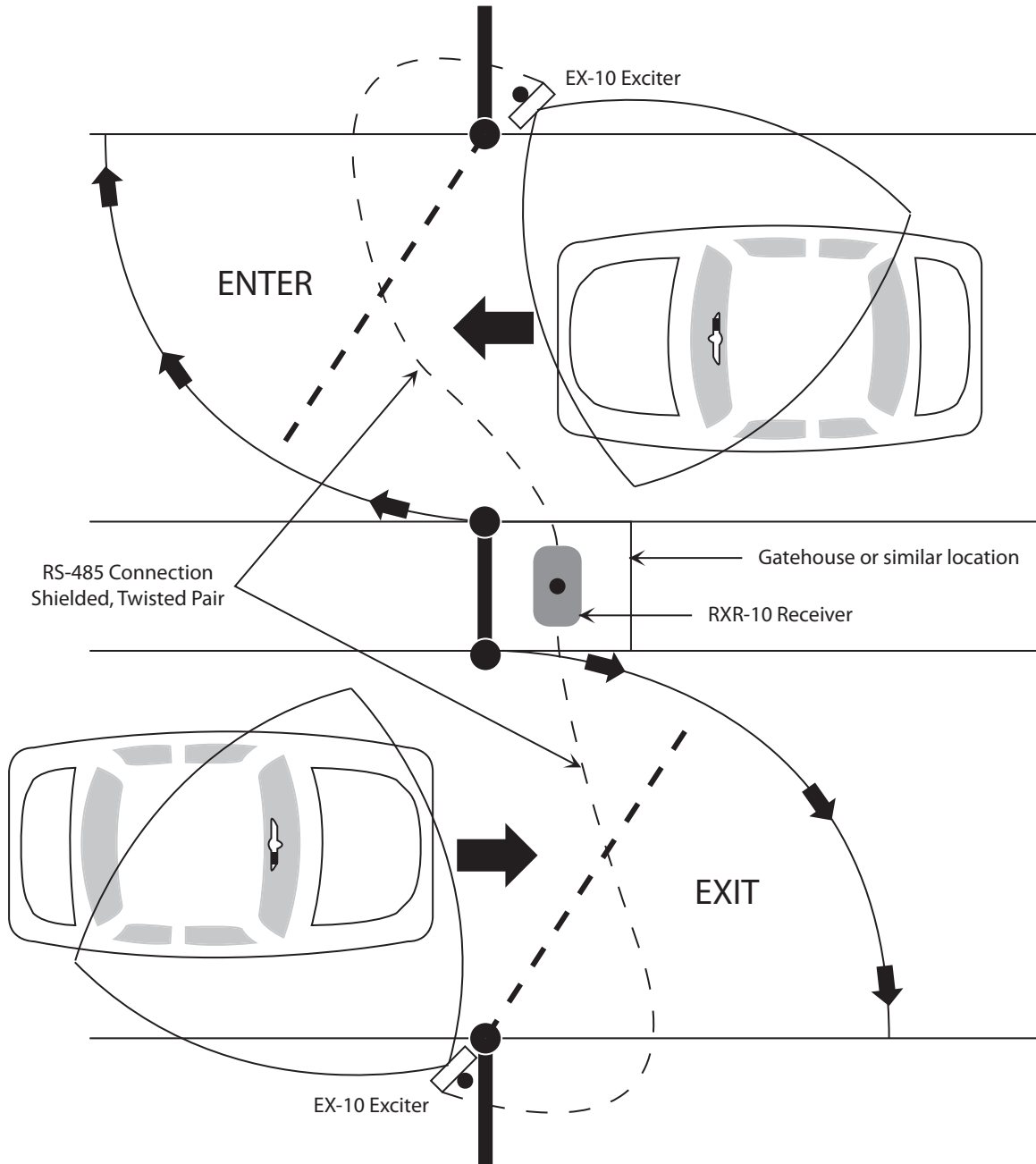

Figure 10: V-Track Enter-Exit Lane Application

V-Track™ Automatic Long Range Vehicle ID System

Installation Guide

For Enter-Exit applications, the RS-485 electrical interface must be connected between the two EX-10 Exciters and the RXR-10 Receiver (see Figure 11 for a wiring diagram). The total length of the RS485 wiring must be less than 500 feet.

NOTE: The RS485 interface is only required for two-lane operation. Single lane installations do NOT require the RS-485 interface to be wired.

6.0.1 System Checkout

The instructions provided in Section 4.0 apply for Enter-Exit operation; however, they need to be performed for each vehicle travel lane independently. You may consider reducing each Receiver's sensitivity to minimize interference between the vehicle travel lanes.

7.0 Wiring Diagrams

7.1 Dual-Lane Exciters to Receiver

This wiring connection applies to systems in Dual-Lane In/Out applications.

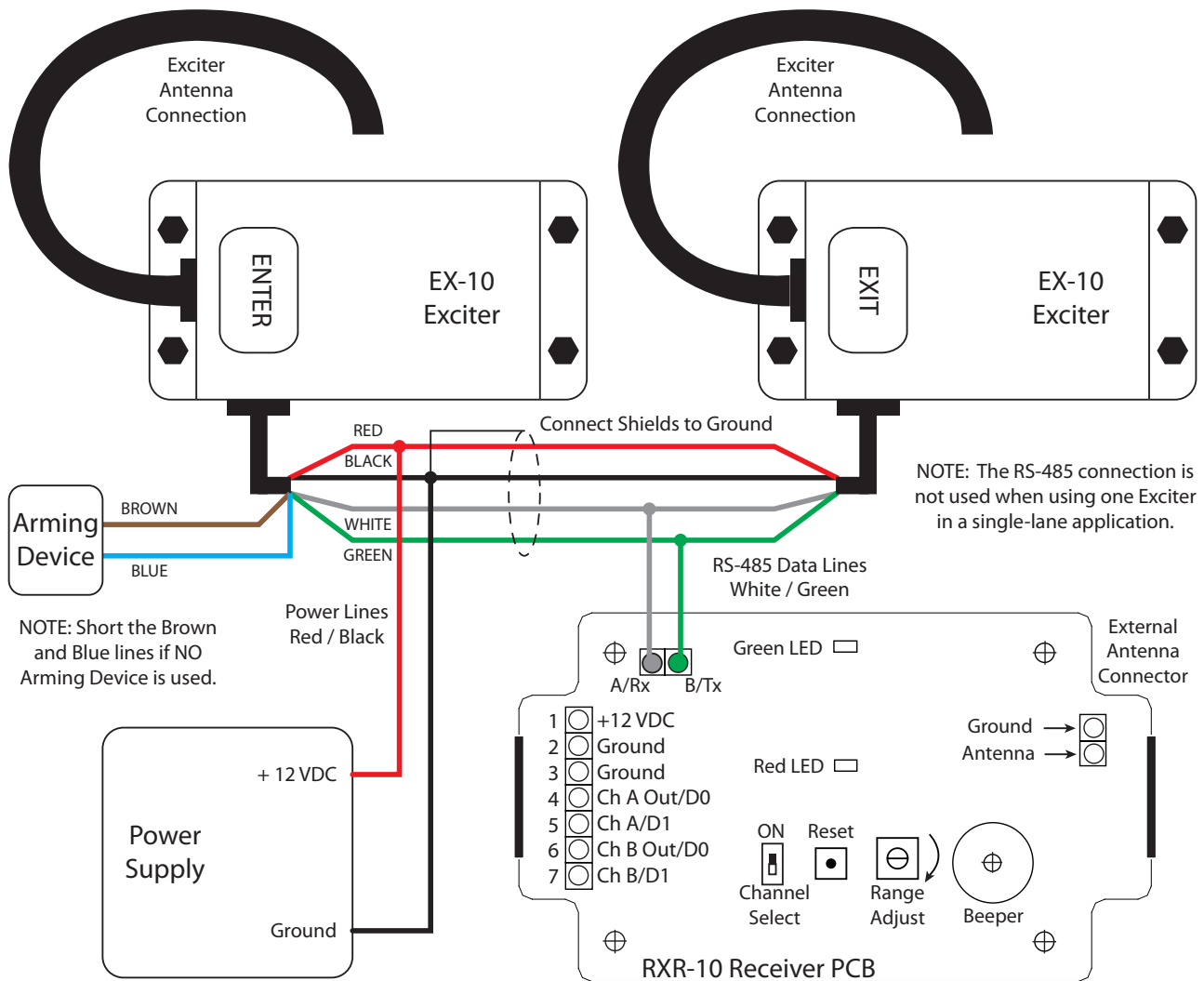

Figure 11: Dual-Lane Exciters to Receiver

V-Track™ Automatic Long Range Vehicle ID System Installation Guide

7.2 Single-Lane Exciter Connection

This wiring connection applies to systems in Single-Lane applications.

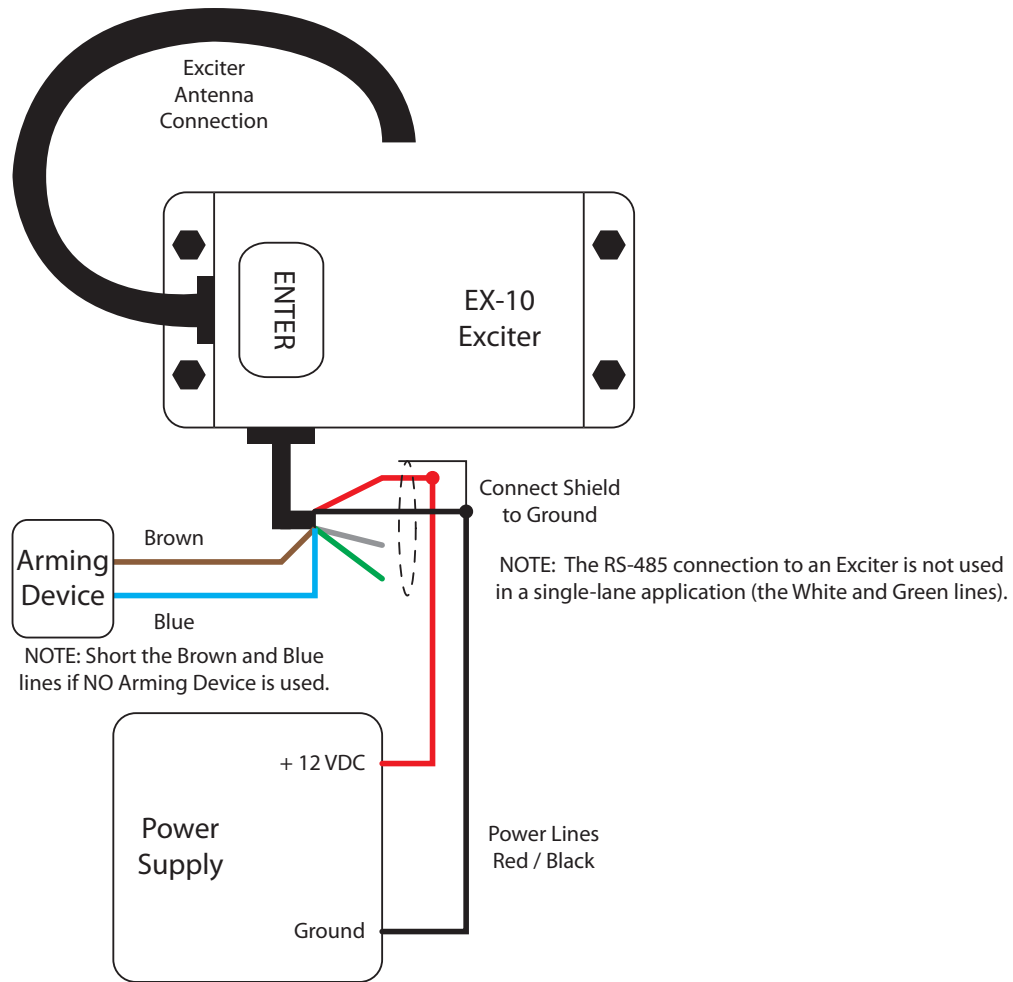

Figure 12: Single-Lane Exciter Connection

V-Track™ Automatic Long Range Vehicle ID System

Installation Guide

7.3 Single Lane Applications

7.3.1 For PXL-P Controllers – Keri MS-Proximity

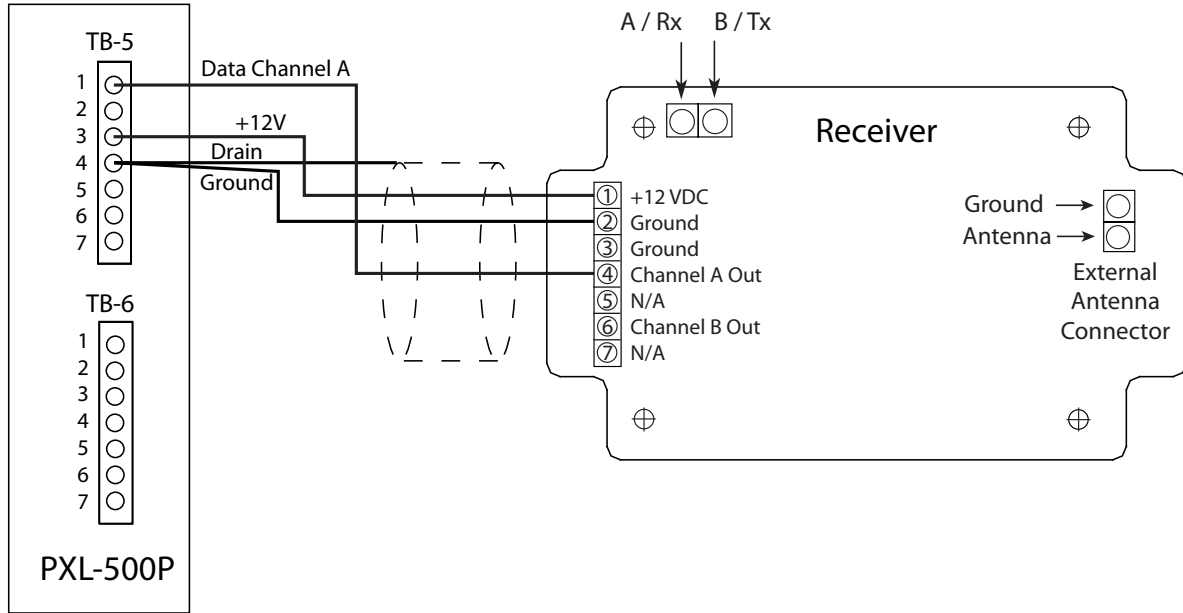

Figure 13: Receiver to PXL-P Controller – Single Lane Application

7.3.2 For PXL-W Controllers – Wiegand

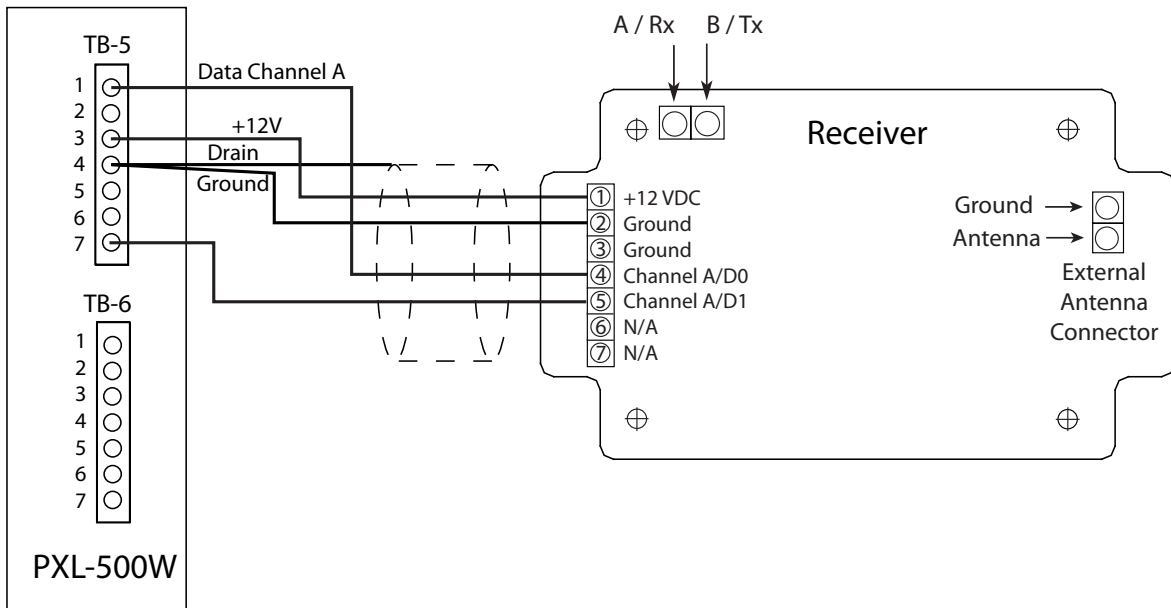

Figure 14: Receiver to PXL-W Controller – Single Lane Application

V-Track™ Automatic Long Range Vehicle ID System

Installation Guide

7.3.3 For NXT Controllers via RIM – Keri MS-Proximity

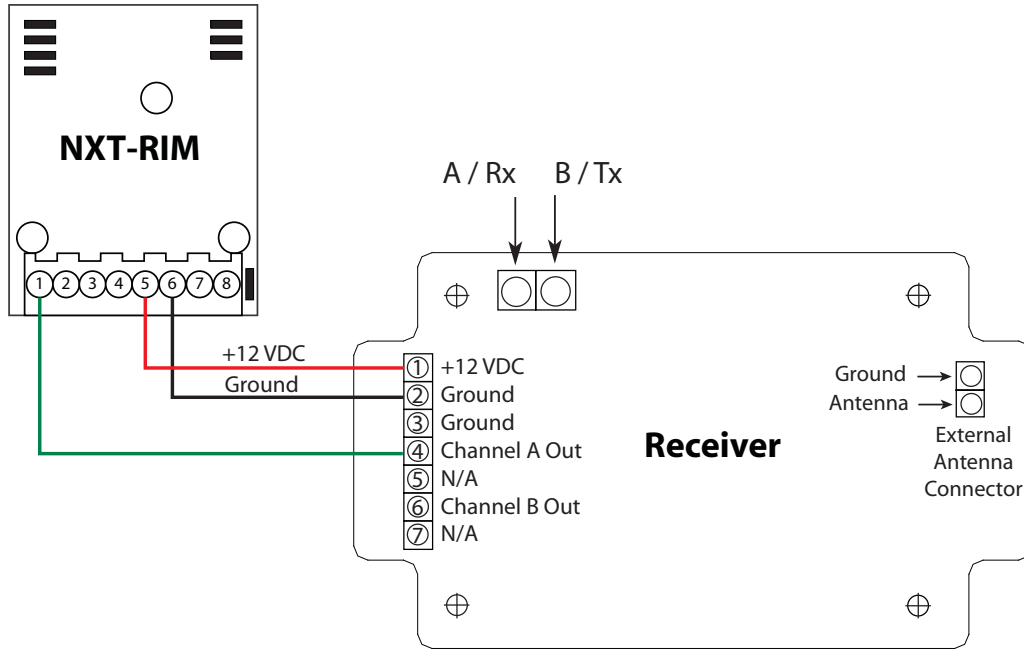

Figure 15: Receiver to NXT Controller via RIM – Keri MS-Proximity – Single Lane Application

7.3.4 For NXT Controllers via RIM – Wiegand

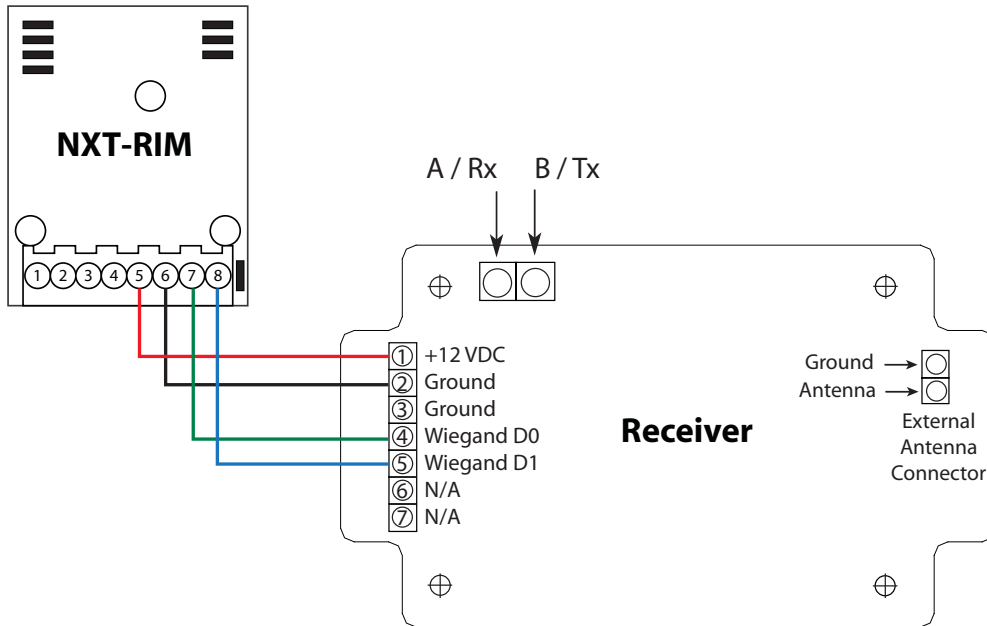

Figure 16: Receiver to NXT Controller via RIM – Wiegand – Single Lane Application

V-Track™ Automatic Long Range Vehicle ID System Installation Guide

7.4 Enter/Exit Two Lane Applications

7.4.1 For PXL-P Controllers – Keri MS-Proximity

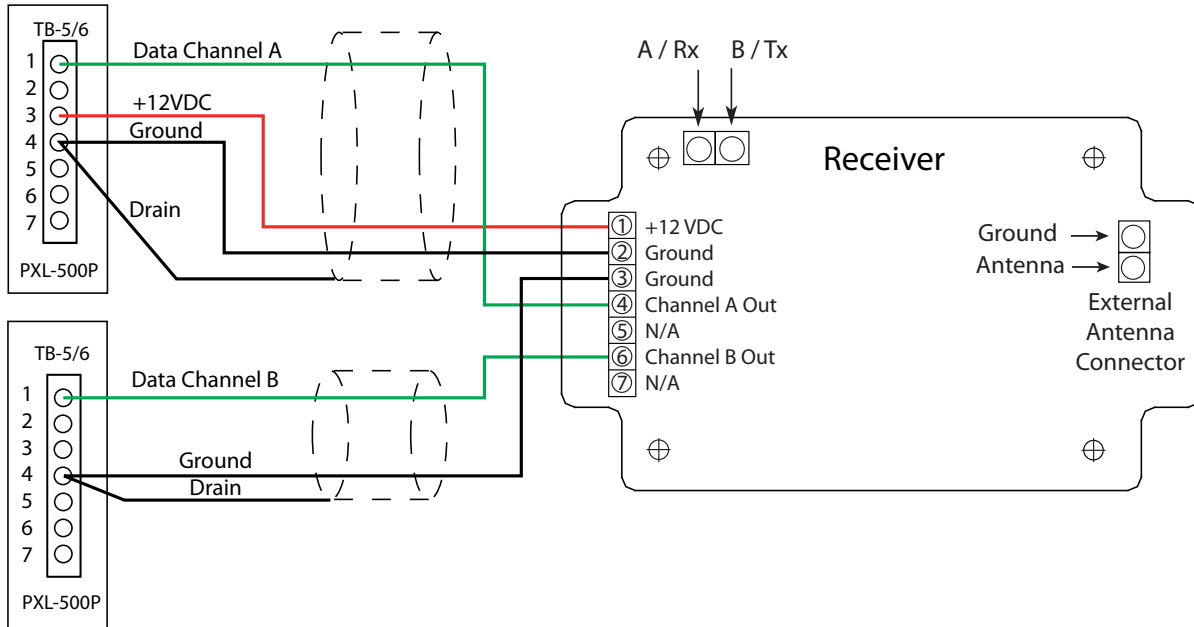

Figure 17: Receiver to PXL-P Controller - Enter/Exit, Two Lane Application

7.4.2 For PXL-W Controllers – Wiegand

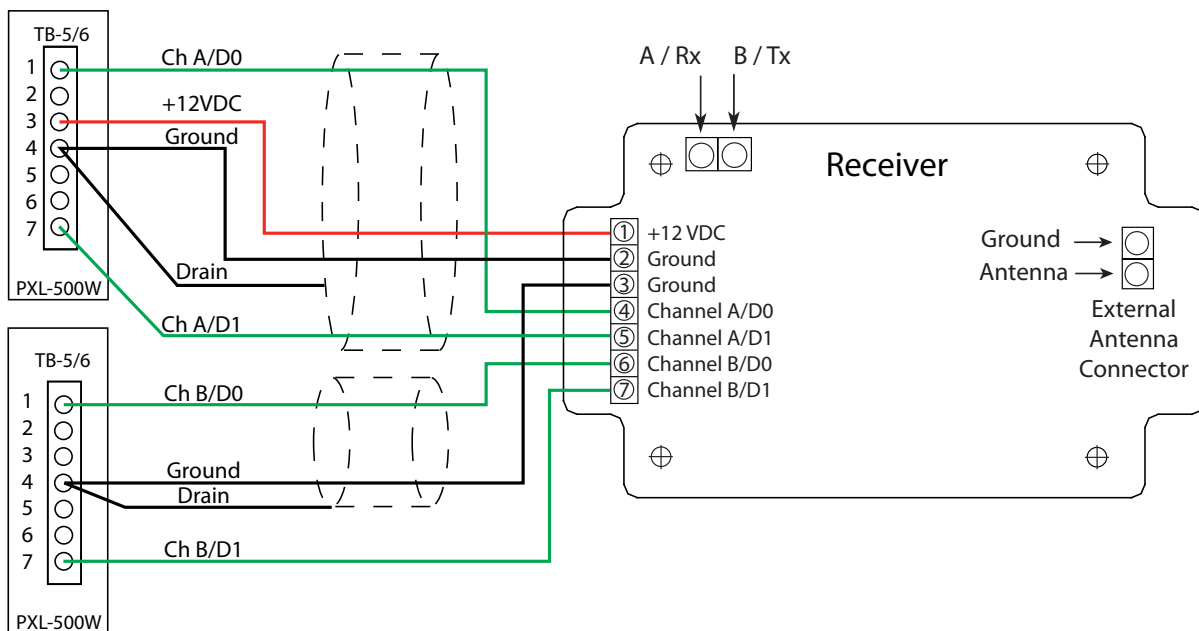

Figure 18: Receiver to PXL-W Controller - Enter/Exit, Two Lane Application

V-Track™ Automatic Long Range Vehicle ID System Installation Guide

7.4.3 For NXT Controllers via RIM – Keri MS-Proximity

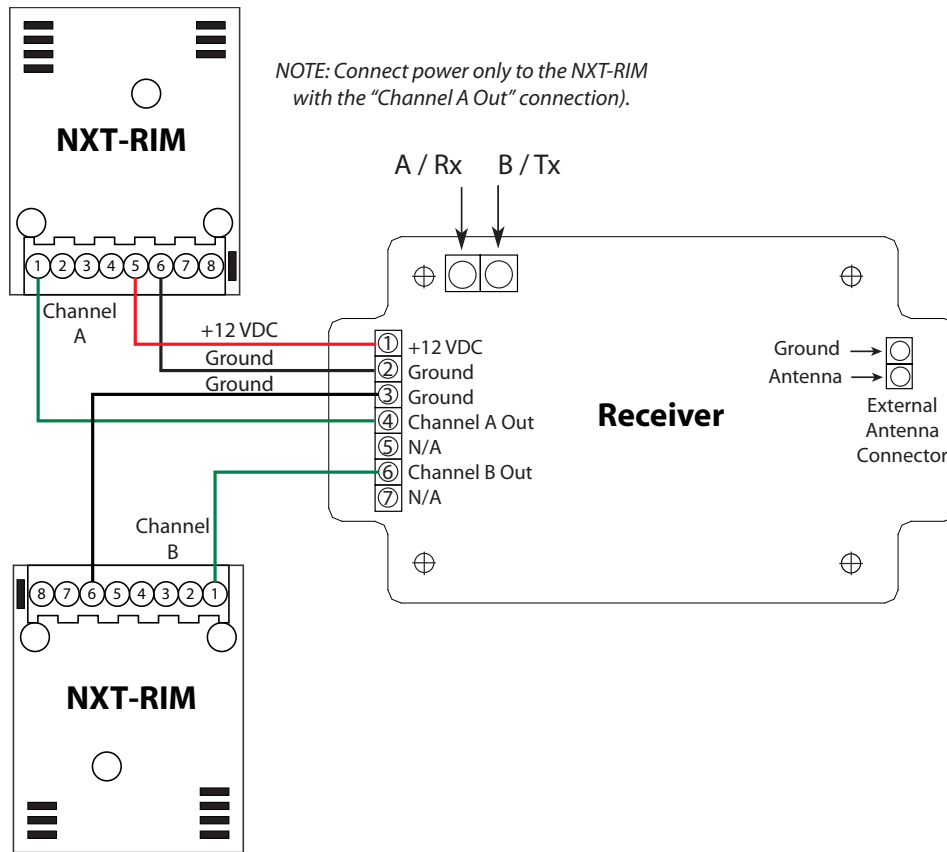

Figure 19: Receiver to NXT Controller via RIM – Keri MS-Proximity – Enter/Exit, Two Lane Application

V-Track™ Automatic Long Range Vehicle ID System

Installation Guide

7.4.4 For NXT Controllers via RIM – Wiegand

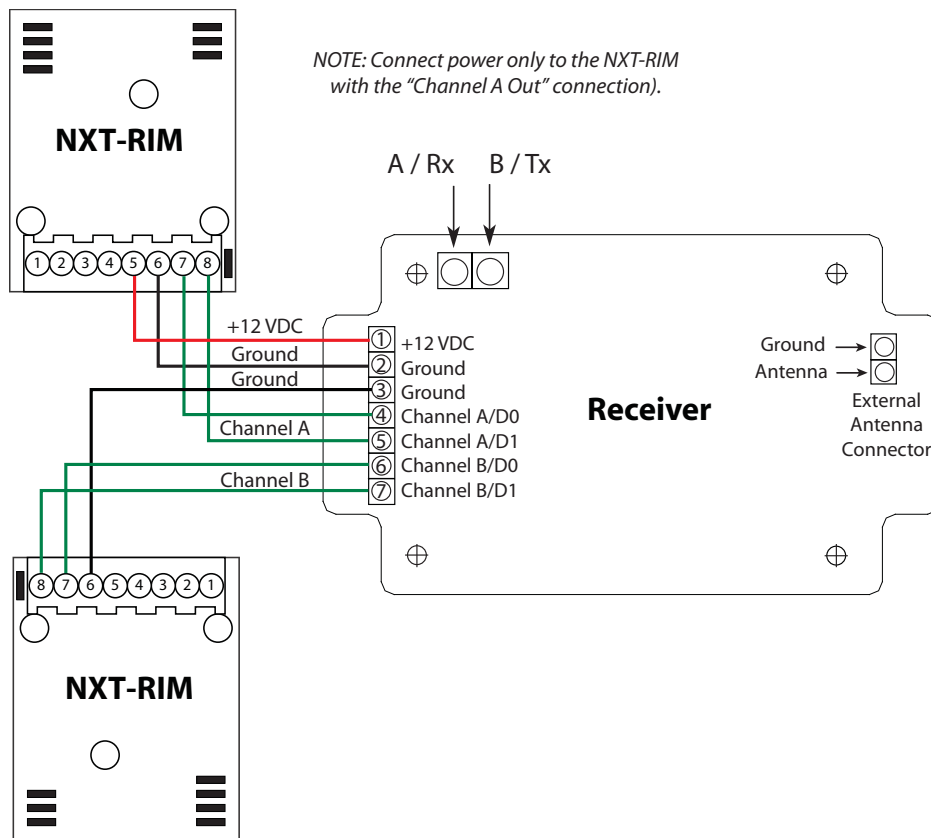

Figure 20: Receiver to NXT Controller via RIM – Wiegand – Enter/Exit, Two Lane Application

8.0 Contact Keri Systems

Keri USA	Keri UK, Ireland, Europe
2305 Bering Drive San Jose, CA 95131	Unit 17 Park Farm Industrial Estate Ermine Street Buntingford Herts SG9 9AZ UK
Telephone: (800) 260-5265 (408) 435-8400	Telephone: + + 44 (0) 1763 273 243
Fax: (408) 577-1792	Fax: + 44 (0) 1763 274 106
Web: www.kerisys.com	Web: www.kerisystems.co.uk
E-mail: sales@kerisys.com techsupport@kerisys.com	E-mail: sales@kerisystems.co.uk tech-support@kerisystems.co.uk

- end of document -