

Do you require maximum pressure stability in your gas supply?

Rely on **40 years of experience** in dome-loaded pressure regulation. Dynamic WITT regulators ensure a stable, adaptable operating pressure for your processes.

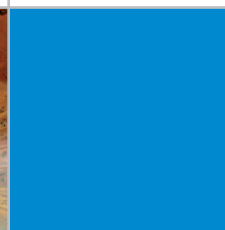

STABLE OPERATING PRESSURE WITH WITT DOME-LOADED PRESSURE REGULATORS

THE PROBLEM

Pressure fluctuations in the gas supply are a risk factor in every industrial manufacturing process. Deviations in the gas pressure due to withdrawal fluctuations pose a threat to the quality of downstream processes and can make products unusable.

THE SOLUTION

Dome-loaded pressure regulators ensure maximum stability of the gas pressure even in case of withdrawal or inlet pressure fluctuations, thus ensuring maximum process safety.

WHY WITT?

With a special design, complex stream simulations and filed detailed solutions, WITT has optimised the functioning of dome-loaded pressure regulators. An excellent advantage of WITT dome-loaded pressure regulators over the conventional pressure controllers is their extremely stable outlet pressure even in case of great withdrawal or inlet pressure fluctuations. The regulations characteristics are extremely stable even in case of extremely high or low flow rates in the limiting performance range. The WITT dome-loaded pressure regulators realise precise regulation even at large pressure differences. A two-stage pressure regulation is no longer necessary in most of the cases.

WITT offers a wide range of high-performance and low-maintenance dome-loaded pressure regulators that are suitable for large flow rates of several thousand m³/h as well. Even low pressure differences of less than 1 bar between the inlet pressure and outlet pressure can be accurately regulated. The own medium control makes additional gas for the pilot pressure regulator redundant. The pilot pressure regulator (or an electrically controlled proportional valve) enables maximum flexibility and the outlet pressure can be easily adjusted. This makes it possible to respond to temperature fluctuations or changes in the downstream process immediately.

The compact regulators, made of either stainless steel or brass, enable large withdrawal ranges, are suitable for numerous technical, corrosive and aggressive gases and can be mounted irrespective of the orientation. Dome-loaded pressure regulators from WITT are available individually or as a completely assembled set including pilot pressure regulator, pressure gauges, fittings and a non-return valve.

Dome-loaded pressure regulators by WITT: probably the best dome-loaded pressure regulators in the world.

OUR RANGE

- High flow rates (up to Kv value 15)
- Inlet pressures of up to 300 bar
- Outlet pressures between 100 mbar and 45 bar
- Useable for almost all gases as well as for corrosive and aggressive mediums
- In brass, stainless steel and aluminium
- Different connections
- Wall bracket (optional)
- Filter for long durability (optional)
- All models available as a ready-to-install completely mounted and tested set (incl. pilot pressure regulator, pressure gauges and connections)

APPLICATIONS (EXAMPLE)

- Chemical industry
- Petrochemistry
- Oil & gas / energy generation
- Pharmaceuticals
- Automobile/shipbuilding
- Mechanical and system engineering
- Food industry
- Mining
- Semiconductors & photovoltaics

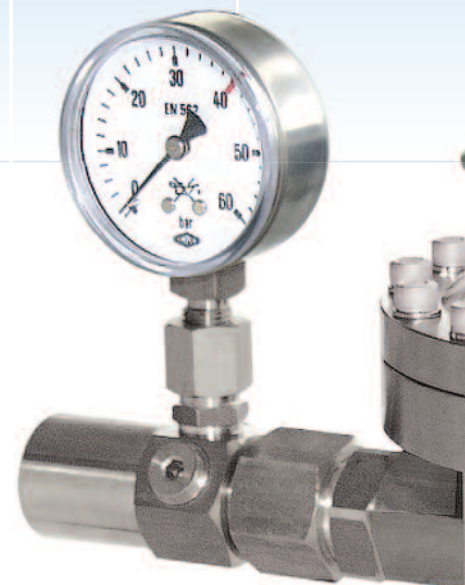



PRECISE STABLE DYNAMIC



PROBABLY THE BEST DOME-LOADED PRESSURE REGULATORS IN THE WORLD

FUNCTION

Dome-loaded pressure regulators are operated with gas pressure. Unlike spring-loaded pressure controllers, the opening force of the valve required for pressure reduction is generated by the pressure of a so-called pilot gas and not by a spring. The pilot gas is supplied to the pressure chamber. In the pressure chamber, the pilot gas acts on a diaphragm whose stroke movement is transferred to the valve seat via a diaphragm plate. The gas to be

regulated is supplied to the dome where it reaches the valve seat. The pressure of the pilot gas and the relevant stroke movement of the diaphragm lead to the valve opening or closing, depending on the operating pressure set, and the required quantity of the gas being supplied further. The excess pilot gas is supplied to the back pressure side or blown off. The pressure of the pilot gas is regulated via a separate pilot gas regulator or a proportional valve.

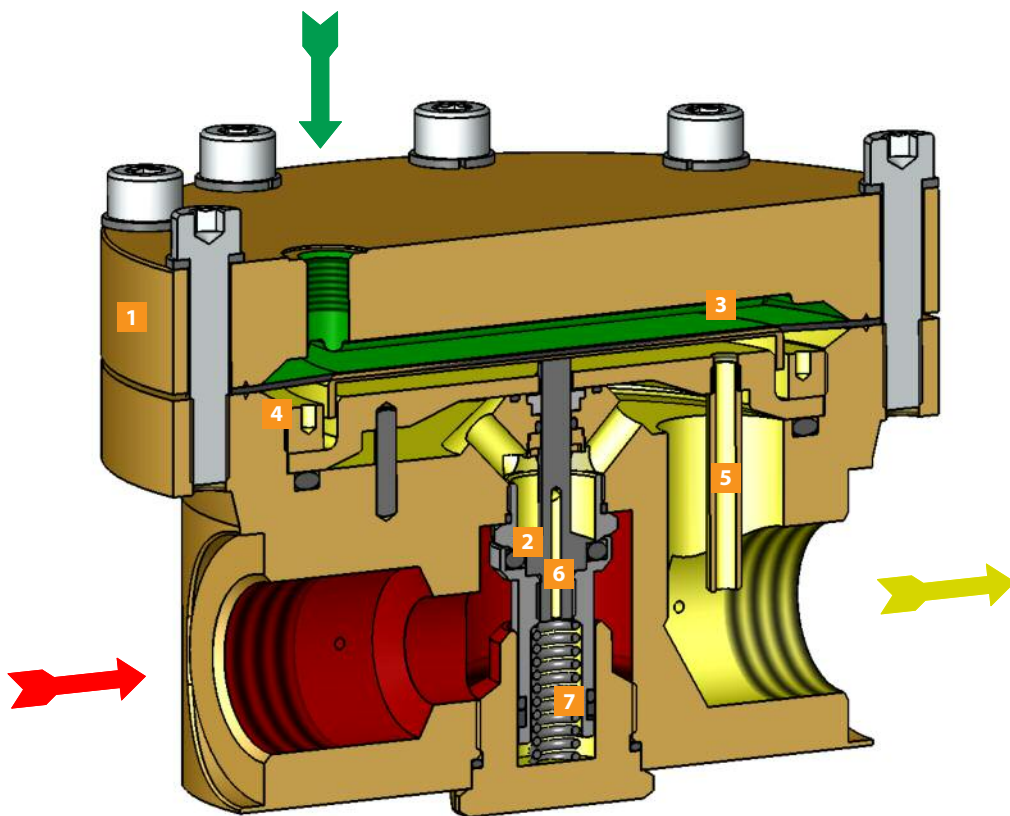

- Inlet pressure
- Pilot pressure
- Outlet pressure

- 1 Body**
either in brass or in high-quality 1.4404 stainless steel
- 2 Valve seat**
- 3 Diaphragm**
A large diaphragm with a wide bearing surface on the diaphragm plate enables accurate regulation
- 4 Diaphragm plate**
- 5 Pilot Control Tube**
does not check the existing outlet pressure on the valve seat but at the output of the pressure regulator where it is relevant for receiving the correct outlet pressure
- 6 Balanced Seat Design**
Bore hole through the valve seat that leads the outlet pressure under the valve seat and thus balances it out
- 7 Closing spring**

DIAPHRAGM

Unlike many other designs, the diaphragm of WITT products is not located directly on the valve seat. Instead, it transfers the stroke movement via a special diaphragm plate. This allows extremely fast adaptation to withdrawal changes. There are no fluctuations in the outlet pressure till the pressure controller finds the correct valve opening. The special diaphragm also enables an extremely wide regulation range. The pressure is accurately regulated even in case of small pressure differences of less than 1 bar in the inlet pressure and the outlet pressure. Large pressure differences can also be realised.

BALANCED SEAT DESIGN

A bore hole through the valve seat and a special sealing of the stroke movement balance out the valve from both sides on an even surface by back pressure. The inlet pressure does not act on the valve piston and the outlet pressure is almost independent of the inlet pressure fluctuations.

PILOT CONTROL TUBE

Unlike other regulators, most of the WITT dome-loaded pressure regulators do not check the existing outlet pressure on the valve seat but at the output of the pressure regulator where it is relevant for the correct outlet pressure control. This allows highest precision in pressure regulation.

PILOT PRESSURE REGULATOR

A major advantage of most of the WITT dome-loaded pressure regulators is their easy and flexible use. The pilot pressure regulator can be used to adjust the operating pressure as soon as a different gas pressure is required at the outlet point or the gas or ambient temperature changes significantly.

CLOSED CONTROL SYSTEM

WITT dome-loaded pressure regulators are flexible as regards the gas supply. Either the regulated gas (internal medium) or a separate gas (external medium) can be used as pilot gas. In case of internal medium control, the dome-loaded pressure regulator works autonomously and the pilot gas is then supplied to the outlet pressure side once again. Gas is thus not used for pressure control and there are no additional costs.

BENEFITS

- Precise pressure regulation
- Stable operating pressure even in case of inlet pressure and withdrawal fluctuations
- Accurate control of small pressure differences of less than 1 bar
- Large pressure differences (300 to 10 bar) can be regulated, two-stage control redundant
- Dynamic system with pilot gas regulator for fast and flexible adaptation of the outlet pressure
- The closed control system makes additional gas supply redundant and saves costs
- Useable for almost all gases as well as for corrosive and aggressive mediums
- Different connections, compact design and wall bracket (optional) for easy assembly
- Low maintenance
- All models available ready-to-install as a completely assembled and tested set

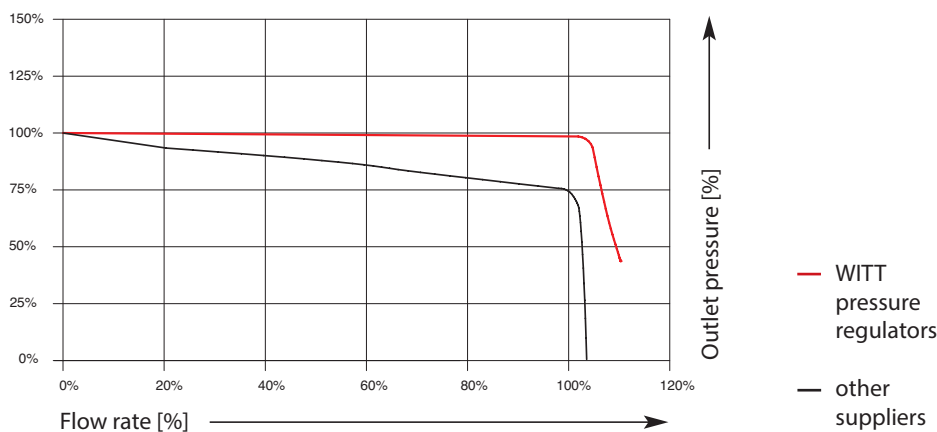

GAS TYPES & MATERIAL

WITT dome-loaded pressure regulators are made of high-quality materials and are ideal for a wide range of gases and applications. Depending on the requirement, the devices can be made from a wide range of body materials and material combinations for diaphragms and seals. For technical gases for instance, the standard body material is brass. The diaphragm is made of a specially coated fabric lining.

For aggressive and corrosive gases, housings are made of 1.4404 stainless steel (AISI 316L). This material offers high resistance against acid and corrosion. The diaphragm is made of FPM which is as well very durable and resistant. These materials cover the most aggressive applications and ensure the quality of your processes.

Gas type	Body material	Diaphragm / seal material
Technical gases	Brass	Elastomer (CR/NBR)
Aggressive gases (e.g. chlorine), corrosive gases (e.g. biogas)	1.4404 stainless steel (316L stainless steel)	Elastomer (FPM)

STANDARDS AND REGULATIONS

Latest production technologies and a complex quality management system ensure maximum WITT quality that you can trust. WITT dome-loaded pressure regulators are manufactured taking into account the rules of technology and the relevant safety regulations for designing, material selection and resistance. All organisational, commercial and technical activities affecting the quality have been appropriately planned, controlled and monitored in our QM manual.

WITT and WITT products also fulfil all relevant international standards and norms, e.g. DIN EN ISO 9001, DIN EN ISO 14001, DIN EN ISO 22000, ATEX 94/9/EC and PED 97/23/EC.

In the course of ATEX, WITT dome-loaded pressure regulators were subjected to an ignition hazard analysis as per EN 1127-1, DIN EN 13463-1 and ZH1/200. The controllers can thus be used in the explosion group IIC, device category 2.

Moreover, a special test for resistance to internal ignition in case of effect of oxygen pressure surges is conducted by BAM.

With the implementation of ISO 22000, all WITT pressure regulators were subjected to a HACCP analysis and thus fulfil the requirements pertaining to food safety.

The specified certificates and test reports can be provided on request.

MAINTENANCE & ACCESSORIES

WITT dome-loaded pressure regulators require almost no maintenance. A maintenance interval of 5 years is usually sufficient for ensuring complete functionality. In case of use of contaminated gases, regular replacement of all wear parts every 2–3 years is recommended. WITT offers an economical maintenance kit with all the necessary replacement parts for easy maintenance.

WITT dome-loaded pressure regulators are used in various areas of application. There is a wide range of connection adapters for every screw connection for almost any application. All models also have an option of installing or pre-installing a filter. Wall brackets are also optionally available for easy assembly.

DOME-LOADED PRESSURE REGULATOR SETS – READY TO USE!

Make use of our know-how in the field of gas safety technology and buy a ready to use package of the WITT dome-loaded pressure regulator. All models are available as dome-loaded pressure regulator sets, including pilot pressure regulator, inlet and outlet pressure gauges and connections. All components of the complete solution are perfectly concerted to each other. The set is assembled; tested and can be directly used in the process. WITT offers an individual production as per desire and requirement.



BENEFITS

- Ready to use
- Easy to install
- No emission of the pilot gas in the environment – closed system
- Dynamic system, operating pressure can easily be changed
- Available completely in 1.4404 stainless steel or brass

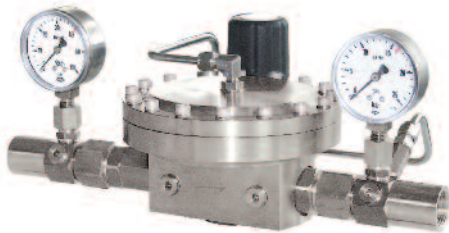

EXAMPLE WITH A PRESSURE CONTROL REGULATOR: CLOSED SYSTEM

- 1 Pilot pressure regulator
- 2 Pressure gauge
- 3 Screw connection
- 4 Filter element (optional)
- 5 Dome-loaded pressure regulator

- Inlet pressure
- Pilot pressure
- Outlet pressure

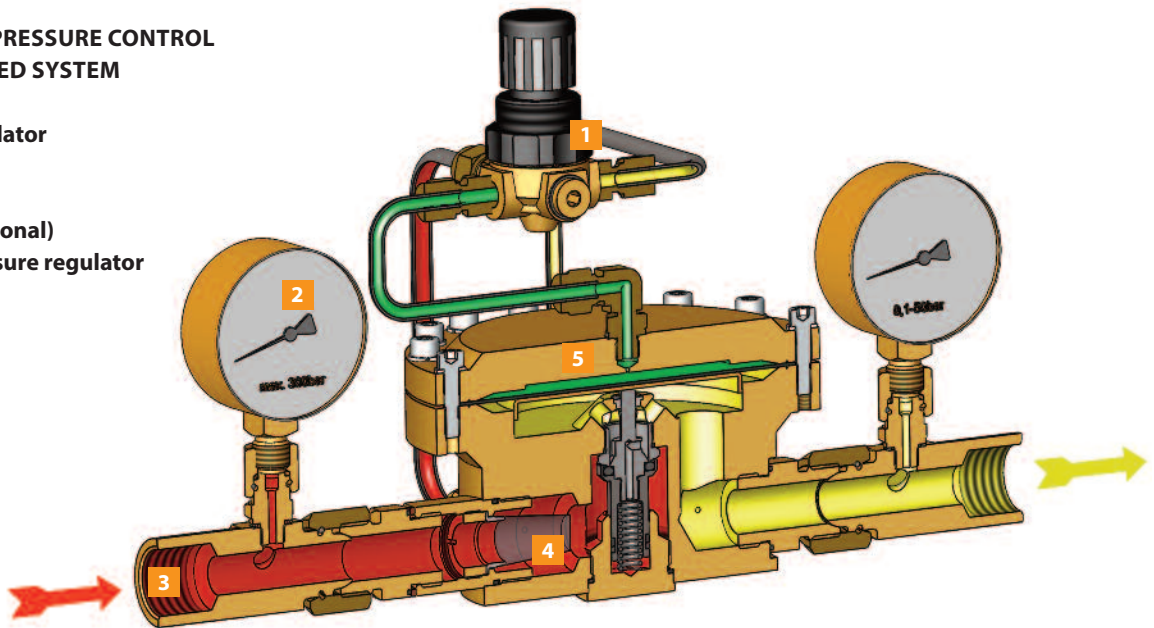

PRODUCT PORTFOLIO

757LE

HIGH PERFORMANCE DOME-LOADED PRESSURE REGULATOR

Kv value: 15 / cv value: 17.4
G 2" female



772LE

UNIVERSAL DOME-LOADED PRESSURE REGULATOR

Kv value: 0.7 / cv value: 0.8
G 3/8" female

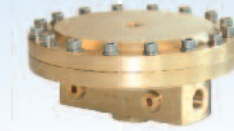

747LE

UNIVERSAL DOME-LOADED PRESSURE REGULATOR

Kv value: 3.6 / cv value: 4.2
G 1" female



737LE HD

HIGH PRESSURE DOME-LOADED PRESSURE REGULATOR

Kv value: 1.65 / cv value: 1.9
G 3/4" female



737LE

UNIVERSAL DOME-LOADED PRESSURE REGULATOR

Kv value: 2.4 / cv value: 2.8
G 3/4" female

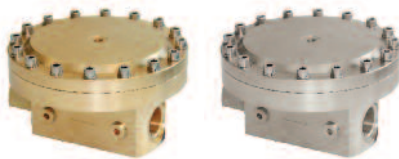

737LE ND

LOW PRESSURE DOME-LOADED PRESSURE REGULATOR

Kv value: 3.6 / cv value: 4.2
G 3/4" female



727LE

MINI HIGH PERFORMANCE DOME-LOADED PRESSURE REGULATOR

Kv value: 1.4 / cv value: 1.6
G 3/8" female



757LE

HIGH PERFORMANCE DOME-LOADED PRESSURE REGULATOR

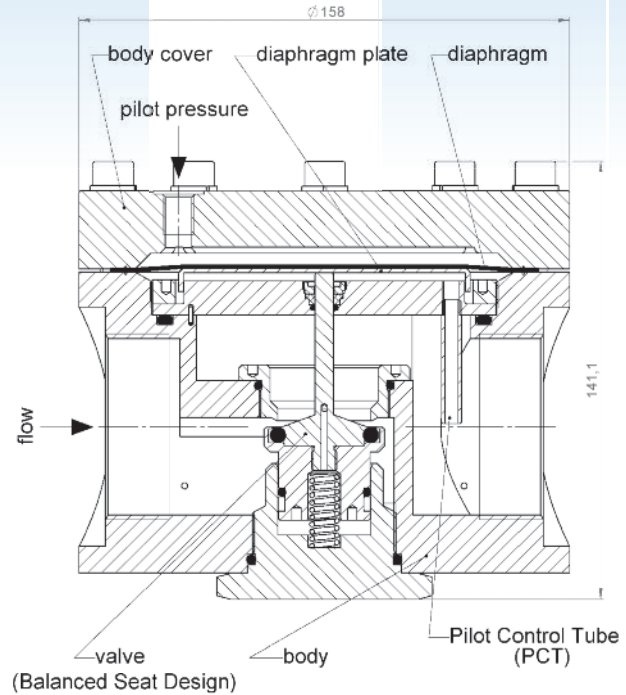
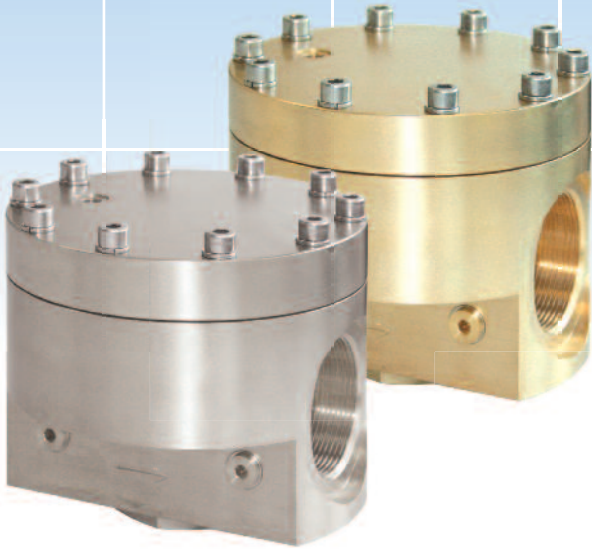

FEATURES

- Kv value: 15 / cv value: 17.4
- High flow rates
- Pilot Control Tube
- Balanced Seat Design
- Suitable for O₂

PRESSURE RANGE

- Max. inlet: 40 bar / 580 psi
(O₂ 30 bar / 435 psi, CO₂ 25 bar / 363 psi)
- Outlet: 0.5–30 bar / 7–435 psi
- Max. pilot: 30 bar / 435 psi

CONNECTIONS

- G 2" female, Flange DN 50 (Set)
(Other connections on request)
- Pilot pressure regulator: G 1/8" female
- Gauge: G 1/8" female

MATERIALS

- Model LE: brass, elastomer
- Model LE-ES:
316L / 1.4404 stainless steel, elastomer

WEIGHT

- approx. 14 kg / 30.9 lb (Brass)

OPTIONAL

- Filter
- Ready to use set

GASES

- LE (brass): technical gases,
e.g. N₂, CO₂, O₂, H₂
- LE-ES (stainless steel): almost all gases,
e.g. N₂, CO₂, O₂, H₂, Cl₂, NH₃, H₂S

FLOW CHART 757LE | NITROGEN (N₂), 20° C

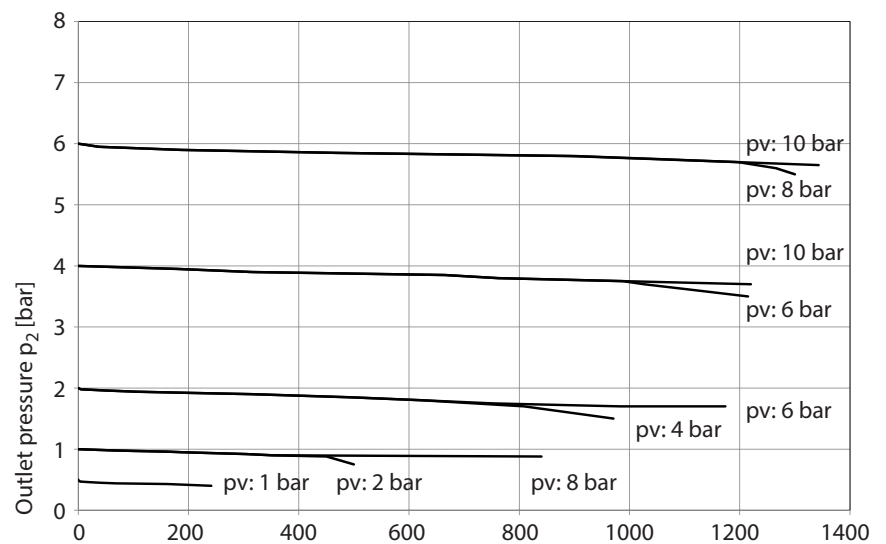

Flow rate [m³/h], pv = Inlet pressure

CONVERSION FACTORS

Ar × 0,84 | Cl₂ × 0,62 | CO₂ × 0,8 | H₂ × 3,73 | He × 2,65 | Natural gas × 1,32 | O₂ × 0,94
1 bar = 14.5 psi | 1 m³/h = 35.3 scfh

747LE

UNIVERSAL DOME-LOADED PRESSURE REGULATOR

(For high flow rates)

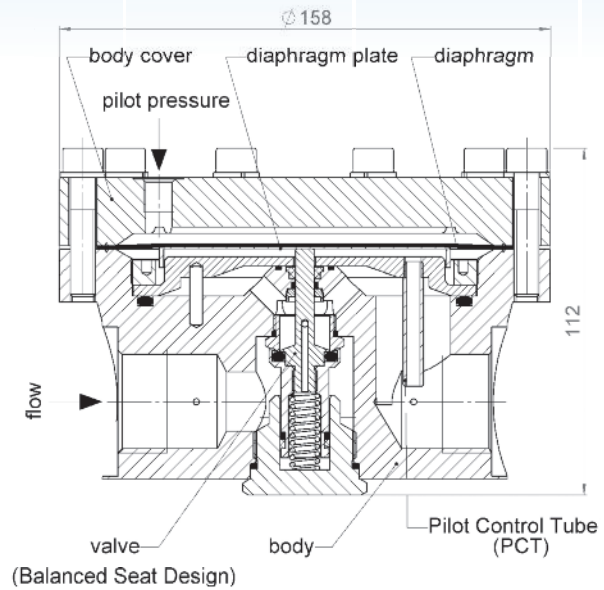
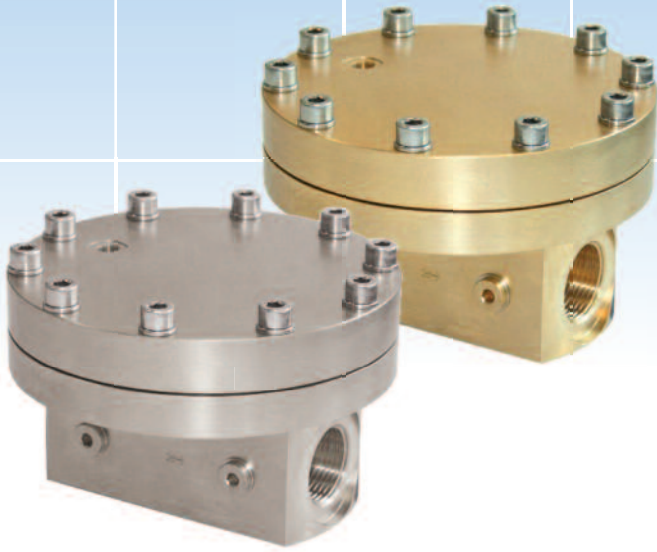

FEATURES

- Kv value: 3.6 / cv value: 4.2
- High flow rates
- Pilot Control Tube
- Balanced Seat Design
- Suitable for O₂

PRESSURE RANGE

- Max. inlet: 40 bar / 580 psi
(O₂ 30 bar / 435 psi, CO₂ 25 bar / 363 psi)
- Outlet: 0.5–30 bar / 7–435 psi
- Max. pilot: 30 bar / 435 psi

CONNECTIONS

- G 1" female
- Pilot pressure regulator: G 1/8" female
- Gauge: G 1/8" female

MATERIALS

- Model LE: brass, elastomer
- Model LE-ES:
316L / 1.4404 stainless steel, elastomer

WEIGHT

- approx. 10 kg / 22 lb (Brass)

OPTIONAL

- Filter
- Ready to use set

GASES

- LE (brass): technical gases,
e.g. N₂, CO₂, O₂, H₂
- LE-ES (stainless steel): almost all gases,
e.g. N₂, CO₂, O₂, H₂, Cl₂, NH₃, H₂S

FLOW CHART 747LE | NITROGEN (N₂), 20° C

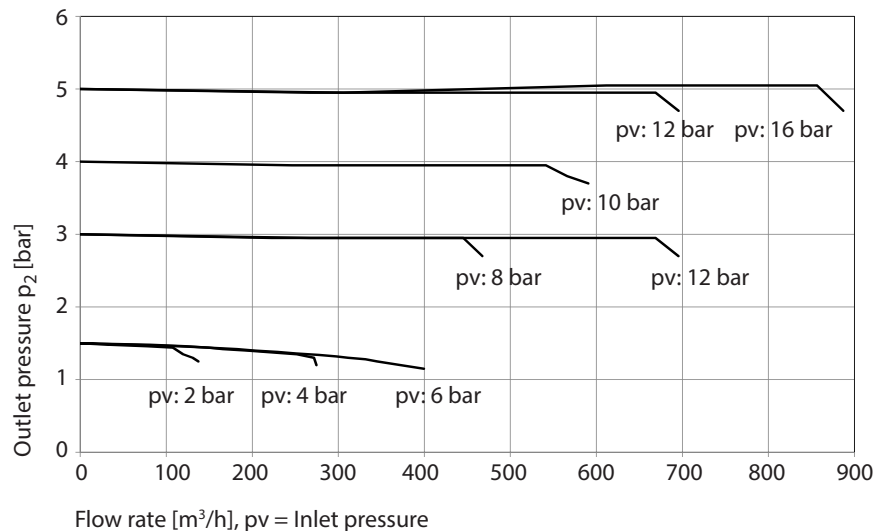

CONVERSION FACTORS

Ar × 0,84 | Cl₂ × 0,62 | CO₂ × 0,8 | H₂ × 3,73 | He × 2,65 | Natural gas × 1,32 | O₂ × 0,94
1 bar = 14.5 psi | 1 m³/h = 35.3 scfh

737LE

UNIVERSAL DOME-LOADED PRESSURE REGULATOR

(For medium flow rates)

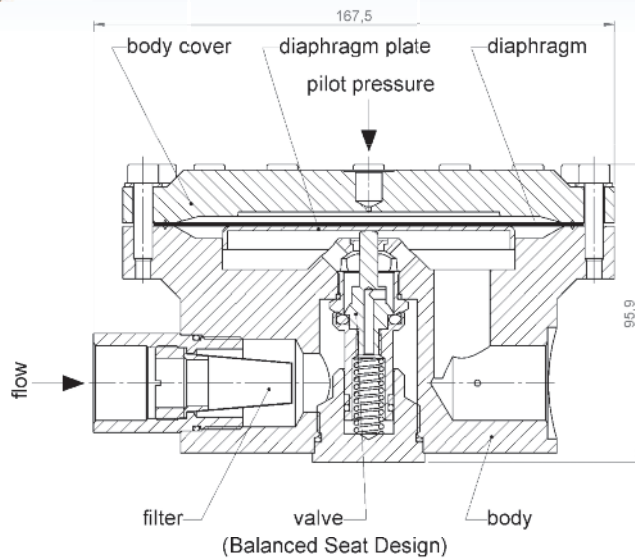
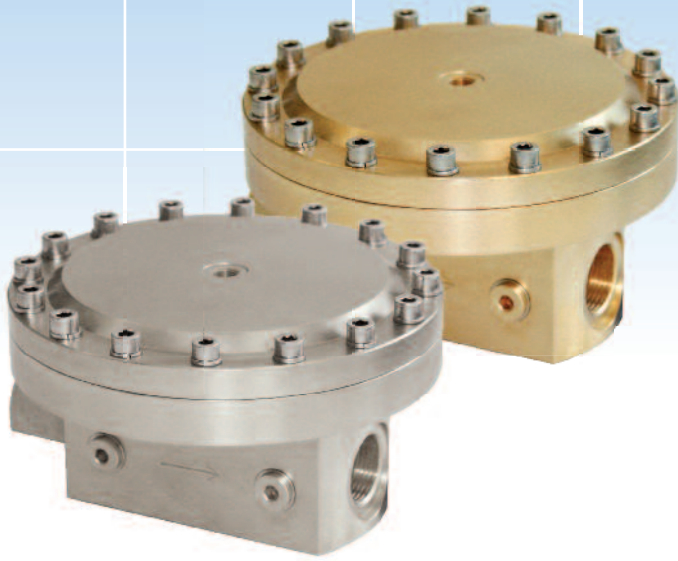

FEATURES

- Kv value: 2.4 / cv value: 2.8
- Balanced Seat Design
- Medium flow rates
- Burn-out safety with oxygen
- Suitable for O₂

PRESSURE RANGE

- Max. inlet: 60 bar / 870 psi
(O₂ 60 bar / 870 psi, CO₂ 25 bar / 363 psi)
- Outlet: 0.5–9 bar / 7–131 psi
- Max. pilot: 10 bar / 145 psi

CONNECTIONS

- G 3/4" female
- Pilot pressure regulator: G 1/8" female
- Gauge: G 1/8" female

MATERIALS

- Model LE: brass, elastomer
- Model LE-ES:
316L / 1.4404 stainless steel, elastomer

WEIGHT

- approx. 8 kg / 18 lb (Brass)

OPTIONAL

- Filter
- Ready to use set

GASES

- LE (brass): technical gases,
e.g. N₂, CO₂, O₂, H₂
- LE-ES (stainless steel): almost all gases,
e.g. N₂, CO₂, O₂, H₂, Cl₂, NH₃, H₂S

FLOW CHART 737LE | NITROGEN (N₂), 20° C

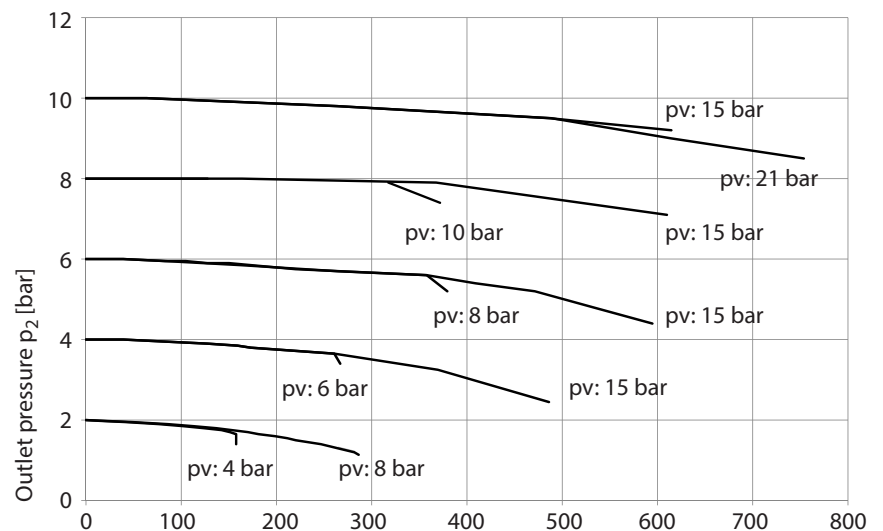

Flow rate [m³/h], pv = Inlet pressure

CONVERSION FACTORS

Ar × 0,84 | Cl₂ × 0,62 | CO₂ × 0,8 | H₂ × 3,73 | He × 2,65 | Natural gas × 1,32 | O₂ × 0,94
1 bar = 14.5 psi | 1 m³/h = 35.3 scfh

727LE

MINI HIGH PERFORMANCE DOME-LOADED PRESSURE REGULATOR

(For medium flow rates)

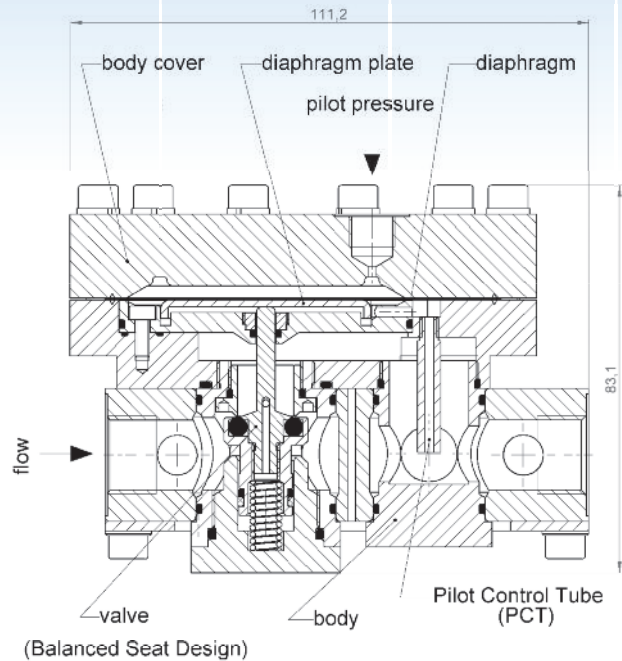
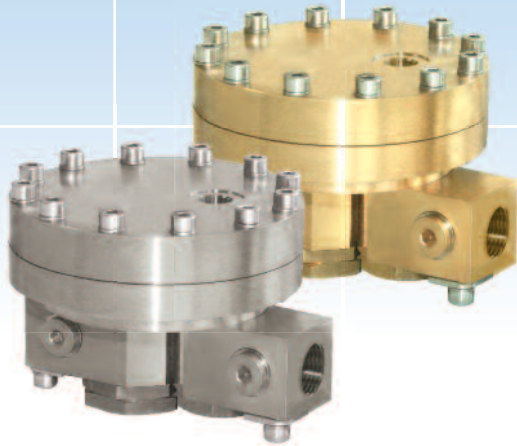

FEATURES

- Kv value: 1.4 / cv value: 1.6
- Pilot Control Tube
- Balanced Seat Design
- Compact design, small size, flexible installation
- Suitable for O₂

PRESSURE RANGE

- Max. inlet: 25 bar / 363 psi
- Outlet: 2–22 bar / 29–319 psi
- Max. pilot: 10 bar / 145 psi

CONNECTIONS

- G 3/8" female
- Pilot pressure regulator: G 1/8" female
- Gauge: G 1/8" female

MATERIALS

- Model LE: brass, elastomer
- Model LE-ES: 316L / 1.4404 stainless steel, elastomer

WEIGHT

- approx. 3 kg / 6.5 lb (Brass)

OPTIONAL

- Filter
- Ready to use set

GASES

- LE (brass): technical gases, e.g. N₂, CO₂, O₂, H₂
- LE-ES (stainless steel): almost all gases, e.g. N₂, CO₂, O₂, H₂, Cl₂, NH₃, H₂S

FLOW CHART 727LE | NITROGEN (N₂), 20° C

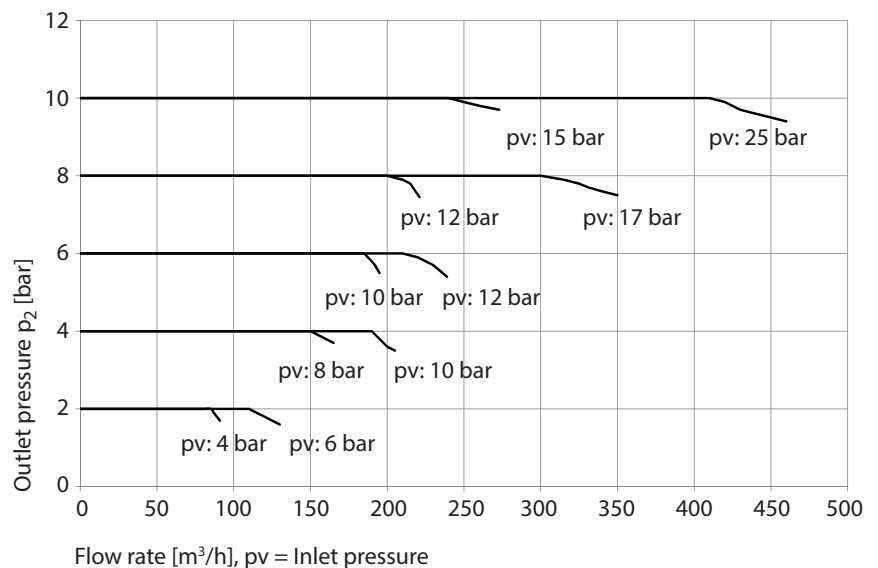

CONVERSION FACTORS

Ar × 0,84 | Cl₂ × 0,62 | CO₂ × 0,8 | H₂ × 3,73 | He × 2,65 | Natural gas × 1,32 | O₂ × 0,94
1 bar = 14.5 psi | 1 m³/h = 35.3 scfh

772LE

UNIVERSAL DOME-LOADED PRESSURE REGULATOR

(For low to medium flow rates)

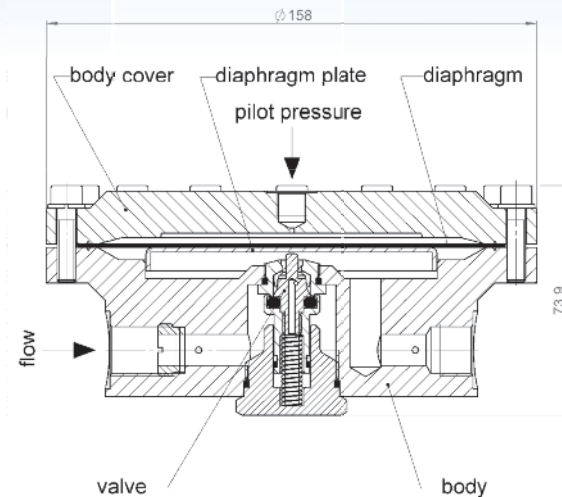
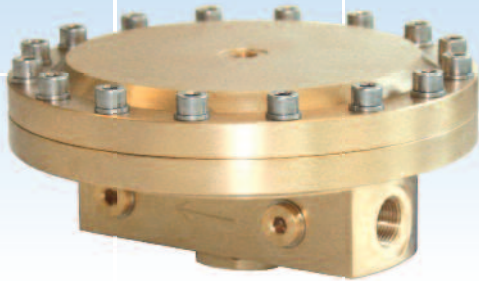

(Balanced Seat Design)

FEATURES

- Kv value: 0.7 / cv value: 0.8
- Balanced Seat Design
- Low to medium flow rates
- Suitable for O₂

PRESSURE RANGE

- Max. inlet: 46 bar / 870 psi
(O₂ 30 bar / 435 psi, CO₂ 25 bar / 363 psi)
- Outlet: 2–9 bar / 29–130 psi
- Max. pilot: 10 bar / 145 psi

CONNECTIONS

- G 3/8" female
- Pilot pressure regulator: G 1/8" female
- Gauge: G 1/8" female

MATERIALS

- Model LE: brass, elastomer

WEIGHT

- approx. 5 kg / 11 lb

OPTIONAL

- Filter
- Ready to use set

GASES

- LE (brass): technical gases, e.g. N₂, CO₂, O₂, H₂

FLOW CHART 772LE | NITROGEN (N₂), 20° C

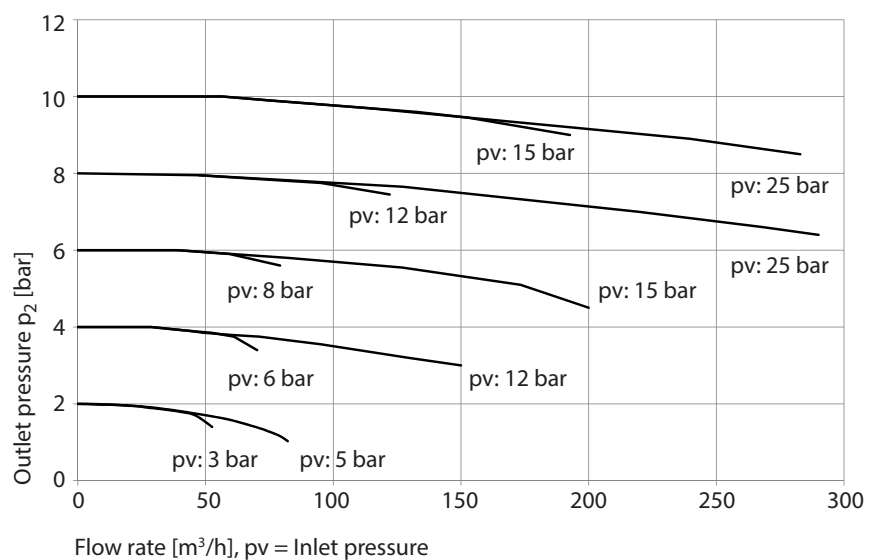

CONVERSION FACTORS

Ar × 0,84 | Cl₂ × 0,62 | CO₂ × 0,8 | H₂ × 3,73 | He × 2,65 | Natural gas × 1,32 | O₂ × 0,94
1 bar = 14.5 psi | 1 m³/h = 35.3 scfh

737LE HD

HIGH PRESSURE DOME-LOADED PRESSURE REGULATOR

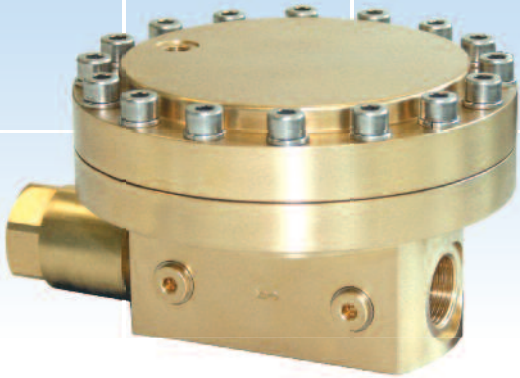

FEATURES

- Kv value: 1.65 / cv value: 1.9
- Balanced Seat Design
- Medium to high flow rates
- High pressure design (300 bar / 4,350 psi)
- Burn-out safety with oxygen
- Suitable for O₂

PRESSURE RANGE

- Max. inlet: 300 bar / 4,350 psi
(O₂ 200 bar / 2,900 psi, CO₂ 60 bar / 870 psi)
- Outlet: 2-45 bar / 29-653 psi
- Max. pilot: 50 bar / 725 psi

CONNECTIONS

- G 3/4" female
- Pilot pressure regulator: G 1/8" female
- Gauge: G 1/8" female

MATERIALS

- Model LE HD: brass, elastomer

WEIGHT

- approx. 10 kg / 22 lb

OPTIONAL

- Filter
- Ready to use set

GASES

- LE HD (brass): technical gases, e.g. N₂, CO₂, O₂, H₂

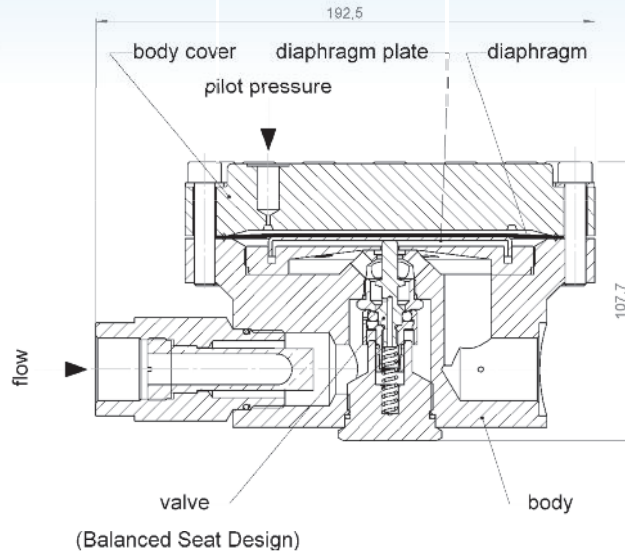

FLOW CHART 737LE HD | NITROGEN (N₂), 20° C

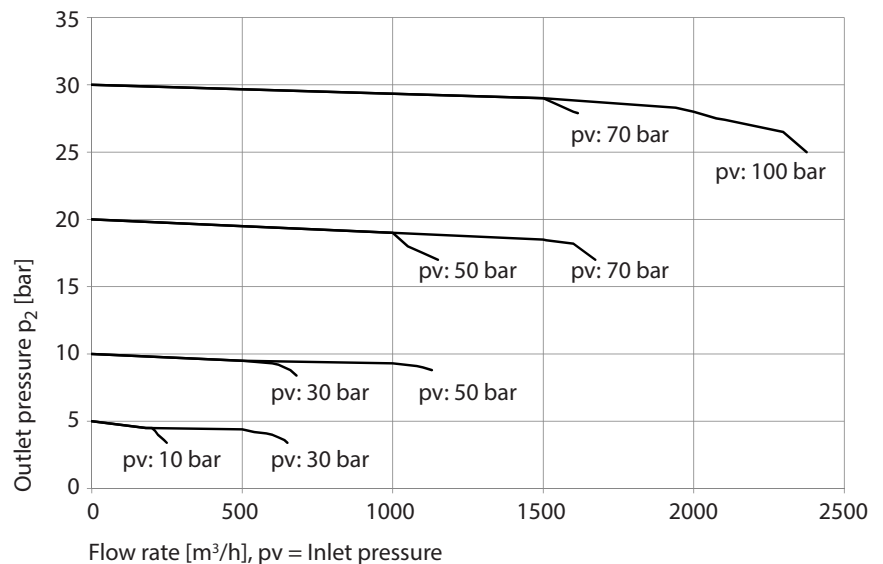

CONVERSION FACTORS

Ar × 0,84 | Cl₂ × 0,62 | CO₂ × 0,8 | H₂ × 3,73 | He × 2,65 | Natural gas × 1,32 | O₂ × 0,94
 1 bar = 14.5 psi | 1 m³/h = 35.3 scfh

737LE ND

LOW PRESSURE DOME-LOADED PRESSURE REGULATOR

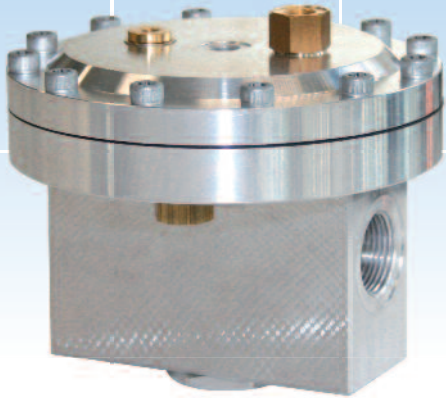

FEATURES

- Kv value: 3.6 / cv value: 4.2
- Medium to high flow rates
- Suitable for O₂

PRESSURE RANGE

- Max. inlet: 10 bar / 145 psi
(O₂ 10 bar / 145 psi, CO₂ 10 bar / 145 psi)
- Outlet: 0.1–2 bar / 1.4–29 psi
- Max. pilot: 2 bar / 29 psi

CONNECTIONS

- G 3/4" female
- Pilot pressure regulator: G 1/8" female
- Gauge: G 1/8" female

MATERIALS

- Model LE ND: aluminium, elastomer

WEIGHT

- approx. 2 kg / 4.5 lb

OPTIONAL

- Filter
- Ready to use set

GASES

- LE ND (aluminium): technical gases, e.g. Ar, N₂, H₂, O₂, He, CO₂, C₄H₈, CH₄

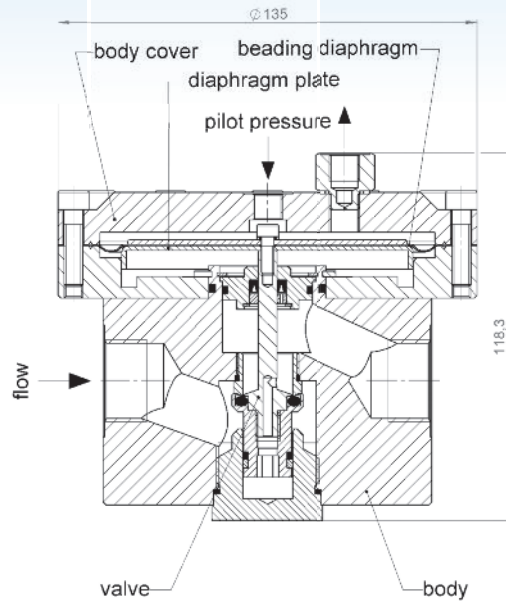

FLOW CHART 737LE ND | NITROGEN (N₂), 20° C

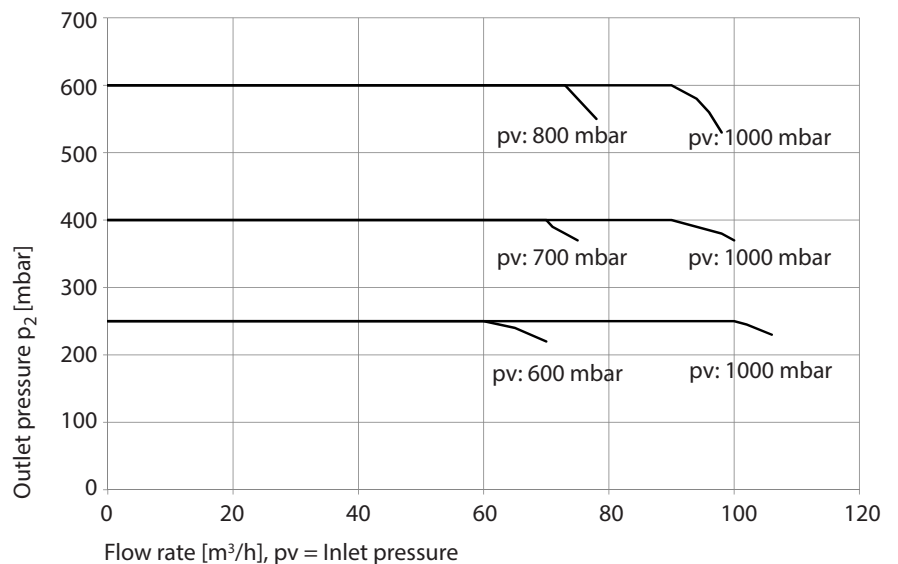

CONVERSION FACTORS

Ar × 0,84 | Cl₂ × 0,62 | CO₂ × 0,8 | H₂ × 3,73 | He × 2,65 | Natural gas × 1,32 | O₂ × 0,94
 1 bar = 14.5 psi | 1 m³/h = 35.3 scfh

▀ **OUR PRODUCT RANGE**

Gas Control Equipment

- Gas mixing systems
- Gas metering systems
- Gas analysers
- Leak detection systems
- Gas pressure vessels
- Engineering of customised systems

Gas Safety Equipment

- Flashback arrestors
- Non-return valves / check valves
- Quick couplers
- Safety relief valves
- Stainless steel devices
- Gas filters
- Pressure regulators
- Outlet points
- Lance holders
- Ball valves
- Automatic hose reels
- Test equipment
- Accessories
- Customised safety equipment

WITT-Gasetechnik GmbH & Co KG

Salinger Feld 4-8 • 58454 Witten
Postfach 2550 • 58415 Witten
Deutschland
Tel. +49 (0)2302 8901-0
Fax +49 (0)2302 8901-3
www.wittgas.com • witt@wittgas.com

WITT Gas Techniques Ltd.

212, Europa Boulevard Westbrook
Warrington, WA5 7TN
Great Britain
Tel. +44 (0)1925 234466
Fax +44 (0)1925 230055
witt-uk@wittgas.com

WITT FRANCE S.A.R.L.

131 Voie de Compiègne
91390 Morsang sur Orge
France
Tel. +33 (0)160 151779
Fax +33 (0)160 154782
witt-france@wittgas.com

WITT Tecnología de Gas, S.L.

C/Simón Cabarga N° 2a – Bajo
39005 Santander
España
Tel. +34 942 835142
Fax +34 942 835143
witt-espana@wittgas.com

WITT Gas Controls LP

380 Winkler Drive, STE 200
Alpharetta, GA. 30004
USA
Tel. 1 888 948 8427
Fax 1 877 948 8427
witt-usa@wittgas.com

WITT POLSKA Sp. z o. o.

ul. Legnicka 62
54-204 Wrocław
Polska
Tel. +48 (0)7135 22856/7
Fax +48 (0)7135 13113
witt-polska@wittgas.com

WITT ITALIA Srl.

Via Giovanni XXIII, 18
24030 Solza (BG)
Italia
Tel. +39 035 4933273
Fax +39 035 4948098
witt-italia@wittgas.com

GUSTUS & PARTNER GmbH

Installation – Service – Wartung
Alt Salbke 6-10, Geb. 59
39122 Magdeburg
Deutschland
Tel. +49 (0)391 4015246
Fax +49 (0)391 4013296
gustus@wittgas.com

Please contact us for partners in your country