

FRONT VIEW WITHOUT PROTECTIONS  
(LOWER POSITION)

Signed as Correct.....

Date.....

Low voltage 'constant pressure' push buttons  
 Fitted with a light duty interfaced lock system  
 Ramp Supplied by customer  
 Height of upper floor gates : 1,100 mm  
 Height of ground floor doors : 2,200 mm

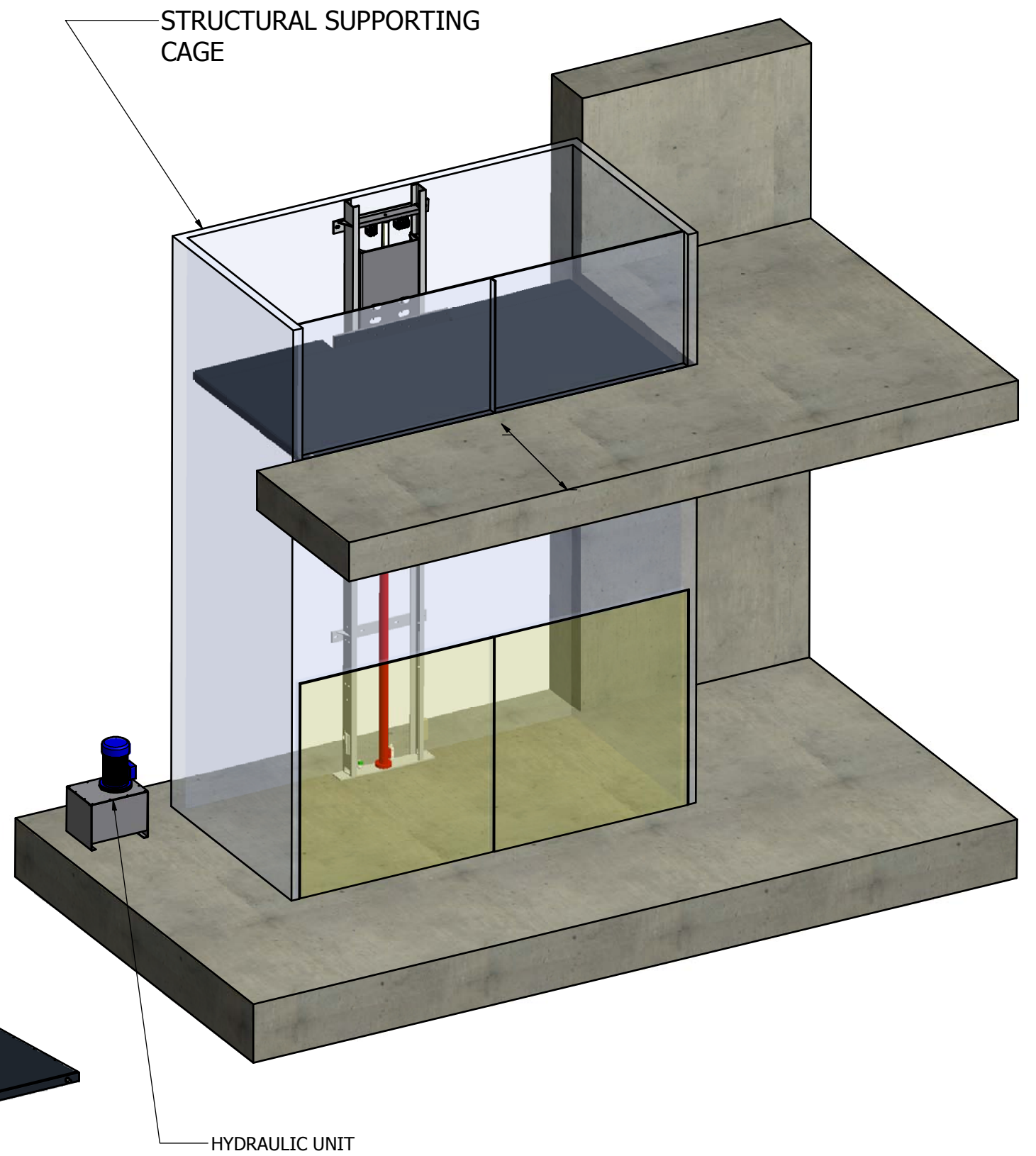
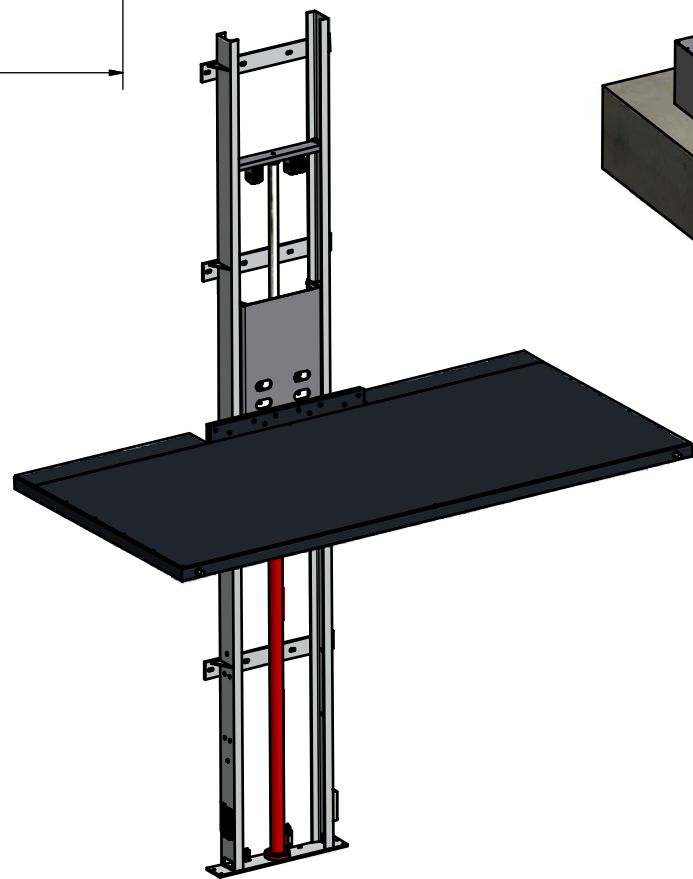

		A2		12/09/2012	MM	MM
		Scala	Formato	Data	Disegnatore	Approvato
Codice	Num. magazzino	Commissa		Gruppo		
Descrizione	Mitras Automotive		Quantita	Trattamento		
Dimensioni	ASSEMBLY		Materiale	Peso tot. N/A		